

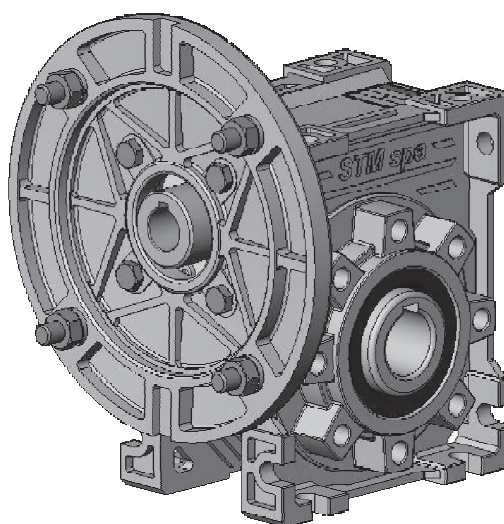

# 1.0 RIDUTTORI UNIVERSALI A VITE SENZA FINE WORM GEARBOXES SCHNECKENGETRIEBE

# U - UI UMI

				Pag. Page Seite
1.1	Caratteristiche tecniche	<i>Technical characteristics</i>	Technische Eigenschaften	C2
1.2	Designazione	<i>Designation</i>	Bezeichnungen	C4
1.3	Versioni	<i>Versions</i>	Ausführungen	C5
1.4	Lubrificazione	<i>Lubrication</i>	Schmierung	C6
1.5	Carichi radiali e assiali	<i>Axial and overhung loads</i>	Radiale und Axiale Belastungen	C8
1.6	Prestazioni riduttori	<i>Gearboxes performances</i>	Leistungen der Getriebe	C10
1.7	Prestazioni motoriduttori	<i>Gearmotors performances</i>	Leistungen der Getriebemotoren	C13
1.8	Dimensioni	<i>Dimensions</i>	Abmessungen	C18
1.9	Accessori braccio di rezione	<i>Accessories torque arm</i>	Zubehör Drehmomentstütze	C20
1.10	Accessori alberi lenti	<i>Accessories output shafts</i>	Zubehör Abtriebswellen	C20
1.11	Linguette	<i>Keys</i>	Federn	C21

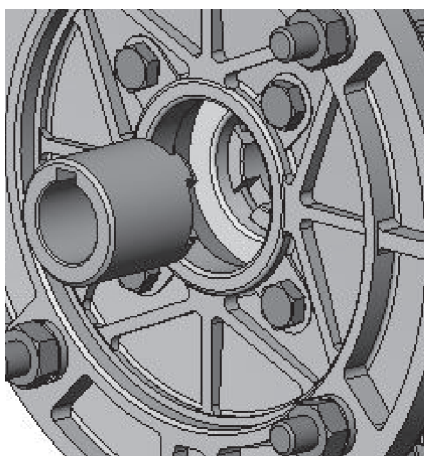



### 1.1 Caratteristiche tecniche

I nostri riduttori a vite senza fine vengono realizzati seguendo il criterio della massima affidabilità nel tempo, risultato ottenuto utilizzando ottimi materiali e moderni criteri di progettazione.

La rettifica sul filetto, nei rapporti di riduzione per i quali il valore del modulo lo consente, viene eseguita con profilo ZI migliorando così i contatti tra le superfici dentate e, conseguentemente, il rendimento e la silenziosità di funzionamento.

Giunto:

#### 1 - ACCIAIO:

- RMI - UMI 50 Ø19
- RMI - UMI 63 Ø24
- RMI - UMI 75 Ø19, Ø24, Ø28
- RMI - UMI 90 Ø19, Ø24, Ø28
- RMI - UMI 110 Ø24, Ø28, Ø38

#### 2 - Tecnopolimero:

- RMI - UMI 40 Ø9, Ø11, Ø14
- RMI - UMI 50 Ø11, Ø14
- RMI - UMI 63 Ø14, Ø19

Sono utilizzati cuscinetti a rulli conici o radiali a sfere di qualità per garantire una lunga durata.

### 1.1 Technical characteristics

*Our gearboxes are manufactured with high quality material and modern design in order to guarantee the maximum reliability and duration.*

*The thread grinding in the gear ratios that the module value permits is carried out with ZI-Profile. This improves the contact between the toothed surfaces and therefore performance and reduces operating noise.*

Coupling

#### 1 - STEEL:

- RMI - UMI 50 Ø19
- RMI - UMI 63 Ø24
- RMI - UMI 75 Ø19, Ø24, Ø28
- RMI - UMI 90 Ø19, Ø24, Ø28
- RMI - UMI 110 Ø24, Ø28, Ø38

#### 2 - Technopolymer:

- RMI - UMI 40 Ø9, Ø11, Ø14
- RMI - UMI 50 Ø11, Ø14
- RMI - UMI 63 Ø14, Ø19

*To guarantee a long life, taper roller bearing or radial ball bearings are used.*

### 1.1 Technische Eigenschaften

Unsere Untersetzungsgetriebe werden unter Verwendung von besten Materialien und mit modernsten Herstellungsmethoden hergestellt, um eine maximale Zuverlässigkeit sowie eine lange Lebensdauer zu garantieren.

Das Gewindeschleifen erfolgt in den vom Modulwert zulässigen Übersetzungsverhältnissen mit ZI-Profil, wodurch die Kontakte zwischen den verzahnten Oberflächen und folglich die Leistung und der geräuscharme Betrieb verbessert werden.

Kupplung

#### 1 - STAHL:

- RMI - UMI 50 Ø19
- RMI - UMI 63 Ø24
- RMI - UMI 75 Ø19, Ø24, Ø28
- RMI - UMI 90 Ø19, Ø24, Ø28
- RMI - UMI 110 Ø24, Ø28, Ø38

#### 2 - Technischer Kunststoff:

- RMI - UMI 40 Ø9, Ø11, Ø14
- RMI - UMI 50 Ø11, Ø14
- RMI - UMI 63 Ø14, Ø19

Um eine lange Lebensdauer zu gewährleisten, werden Kegelrollenlager oder Radialkugellager von hoher Qualität verwendet.



## 1.1 Caratteristiche tecniche

### CARATTERISTICHE PECULIARI:

- Ingombri **Ridotti**;
- Semplicità di connessione;
- **NO** Fretting;
- **NO** Vibrazioni;
- Progettato per garantire efficienza e affidabilità con servizi gravosi in presenza di urti e con numerosi avviamenti.

### MATERIALE:

Technopolimero;  
Acciaio.

### MANUTENZIONE:

- Facilità di Montaggio motore;
- Facilità di Smontaggio

### MODULARITÀ:

-Possibilità di utilizzare il giunto sulle serie "U" - "RMI...G..." - "CRMI...G"- "S".

### TEMPI DI CONSEGNA:

- Maggiore modularità del prodotto;
- Stock a magazzino del prodotto assemblato.

## 1.1 Technical characteristics

### SPECIAL FEATURES:

- Reduced** Sizes
- Simplified connections*
- No** fretting
- No** vibrations
- Designed in order to warrant efficiency and reliability with heavy duty in case of bumps and frequent start-ups**Simplified connections*

### MATERIAL:

Technopolymer;  
Steel.

### MAINTENANCE:

- Easy motor assembly;*
- Easy disassembly.*

### MODULARITY:

*Possibility of coupling's using specially those of "U", RMI...G", - "CRMI...G" - "S" series.*

### DELIVERY DATES

- Higher product's modularity*
- Stock warehouse finished product.*

## 1.1 Technische Eigenschaften

### SONDERMERKMALE:

- Verringerter Platzbedarf;
- Einfacher Anschluss;
- Keine Abnutzung;
- Keine Vibrationen;
- Gewährleistet Effizienz und Zuverlässigkeit bei hoher Belastung, Stossbeeinträchtigung und zahlreichen Maschinen-Starts.

### MATERIAL:

Technischer Kunststoff;  
Stahl.

### WARTUNG:

- Einfacher Motoreinbau;
- Einfacher Ausbau.

### MODULARITÄT

Die Kupplung kann in den Serien „U“ – „RMI...G...“ – „CRMI...G“ und „S“ verwendet werden.

### LIEFERZEITEN:

- Größere Modularität des Produktes;
- Montiertes Produkt im Lagerbestand

C









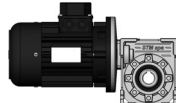

1.2 Designazione

1.2 Designation

1.2 Bezeichnung

		Grandezza Size Größe	Versione Version Ausführung	ir	* IEC	Tipo Type Typ	Grandezza Size Größe	Lunghezza Lenght Länge	Flangia Flange Flansch	Designazione Motori Designation Motors Bezeichnung Motoren <b>CT18IGBD1</b>		
UMI	40 50 63 75 90 110	-	FA	vedi tabelle see tables siehe Tabellen	63 (B5)	T TA .... H	56 .... 315	A .... ML	 (standard)	Esempio / Example / Beispiel		
					63 (B14)					UMI 40 1/20 PAM 63 (B5)		
					....					UMI 40 1/20 T 56 A 4 B5		
UI	75 90 110	FB	C5					 SX	UI 40 1/20			
U									Solo per Only for Nur für FA, FB	U 40 1/20		

\* Se non conforme alle specifiche dimensionali IEC precisare diametro foro e flangia (es. 14/120)

Altre specifiche:

- posizione della morsettiera del motore se diversa da quella standard (1)
- elica della vite sinistra (esecuzione speciale)
- cuscinetti conici corona
- alberi lenti

\* If not conform to IEC specifications please specify diameter of wormshaft's bore and flange (i.e. : 14/200)

Further specification:

- terminal board box position if different from standard (1)
- left helix (special version)
- wormwheel taper roller bearings
- output shafts

\* Falls nicht nach IEC, bitte Durchmesser der Eingangswellenbohrung und des Flansches angeben (z.B.: 14/200)

Weitere Spezifikationen:

- Stellung des Klemmenkastens des Motors, falls diese von der Standard- Ausführung abweicht (1)
- Linksgängige Schraubenlinie der Schnecke (Spezialausführung)
- Kegelrollenlager auf der Schnecke
- Abtriebswellen



1.3 Versioni

1.3 Versions

1.3 Ausführungen

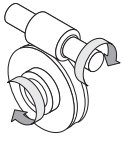

Il senso dell'elica è destro  
The helix is right-handed  
Die Schnecke ist rechtsgängig

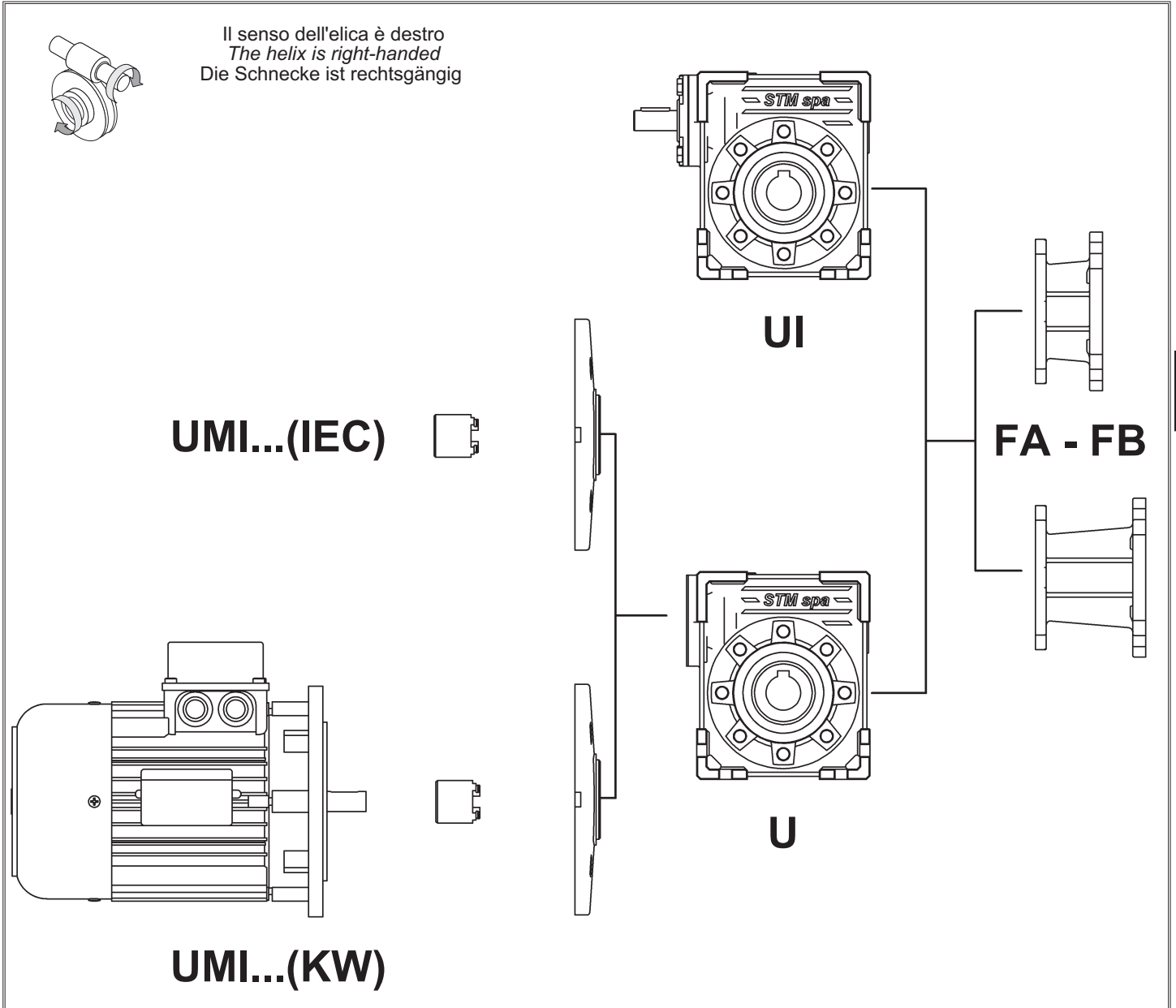

Posizione morsettieria - Terminal board position - Lage des Klemmenkastens

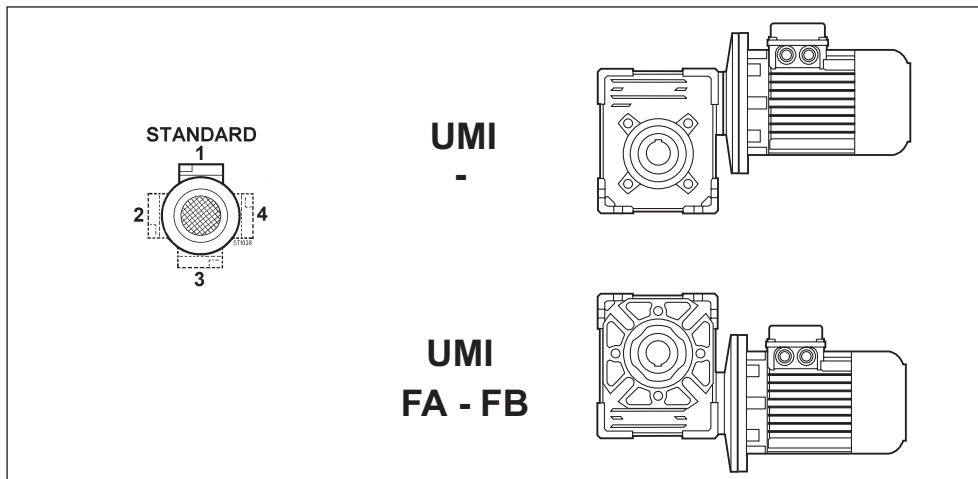



## 1.4 Lubrificazione

## 1.4 Lubrication

## 1.4 Schmierung

Lubrificazione riduttori  
Gearboxes lubrication  
Schmierung Getriebes

## U - UI - UMI

**Generalità**

Si consiglia l'uso di oli a base sintetica. Vedere a tale proposito le indicazioni riportate nel capitolo A, paragrafo 1.6 e 1.2. Nella tab. 2.2.1 sono riportati i quantitativi di olio necessari per il corretto funzionamento dei riduttori.

**Prescrizioni in fase di ordine e stato di fornitura**

I riduttori delle grandezze 40, 50, 63, 75 sono forniti completi di olio sintetico di viscosità ISO 320.

Per questi riduttori **non è necessario** specificare la posizione di montaggio.

I riduttori delle grandezze 90, 110 sono forniti completi di olio sintetico di viscosità ISO 320.

Per questi riduttori **è necessario** specificare la posizione di montaggio.

**General information**

*The use of synthetic oil is recommended. (see details in Chapter A, paragraph 1.6 and 1.2). Tab. 2.2.1 shows the quantities of oil required for correct worm gearbox performance.*

**Ordering phase requirements and state of supply**

*Worm gearboxes sizes 40, 50, 63, 75, and 85 come supplied with ISO 320 viscosity synthetic oil.*

**It is not necessary** to specify mounting positions with these worm gearboxes.

*Worm gearboxes sizes 90, 110 come supplied with ISO 320 viscosity synthetic oil.*

**It is necessary** to specify the mounting position for these worm gearboxes.

**Allgemeines**

Der Einsatz von synthetischem Öl wird empfohlen. (Siehe diesbezüglich die Hinweise im Kapitel A, abschnitt 1.6 und 1.2.)

In der Tabelle Tab. 2.2.1 werden die erforderlichen Öfüllmengen für einen störungsfreien Betrieb der Getriebe aufgeführt.

**Vorgaben für die bestellung und den lieferzustand**

Die Getriebe in den Baugrößen 40, 50, 63, 75 werden komplett mit Synthetiköl mit einer Viskosität ISO 320 geliefert. Für diese Getriebe **muss** die Einbaulage **nicht** angegeben werden.

Die Getriebe in den Baugrößen 90, 110 werden komplett mit Synthetiköl mit einer Viskosität ISO 320 geliefert.

Für diese Getriebe **muss** die Einbaulage verbindlich angegeben werden.

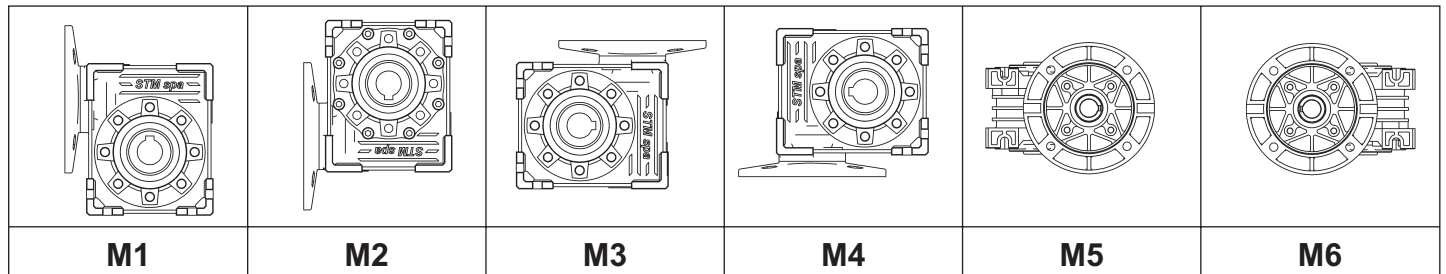
**Posizioni di montaggio UI-UMI****Mounting positions UI-UMII****Montagepositionen UI-UMI**



Tab. 2.2.1

U - UMI	Quantità di lubrificante / Lubricant Quantity / Schmiermittelmenge (kg)						Stato di fornitura State of supply Lieferzustand	n°. tappi olio No. of plugs Anzahl Schrauben	Posizione di montaggio Mounting position Montageposition
	Posizioni di montaggio Mounting Positions Montagepositionen								
	M1	M2	M3	M4	M5	M6			
40			0.100				Riduttori forniti completi di lubrificante sintetico Gearboxes supplied with synthetic oil Getriebe werden mit synthetischem Öl geliefert	1	Non é necessaria It is not necessary Nicht Erforderlich
50			0.150					1	
63			0.300					1	
75			0.600					1	
90			1.000					1	Necessaria Necessary Erforderlich
110	1.600		1.300					1	

Tab. 2.2.2

UI	Quantità di lubrificante / Lubricant Quantity / Schmiermittelmenge (kg)						Stato di fornitura State of supply Lieferzustand	n°. tappi olio No. of plugs Anzahl Schrauben	Posizione di montaggio Mounting position Montageposition
	Posizioni di montaggio Mounting Positions Montagepositionen								
	M1	M2	M3	M4	M5	M6			
40			0.100				Riduttori forniti completi di lubrificante sintetico Gearboxes supplied with synthetic oil Getriebe werden mit synthetischem Öl geliefert	1	Non é necessaria It is not necessary Nicht Erforderlich
50			0.190					1	
63			0.450					1	
75			0.600					1	
90			1.000					1	Necessaria Necessary Erforderlich
110	1.600		1.300					1	

A) Nei riduttori delle grandezze 90-110 è necessario in fase d'ordine indicare la posizione di montaggio sia se i riduttori sono richiesti con olio sia privi di lubrificante. Particolare attenzione va posta per i riduttori montati nelle posizioni M3 e M4 che sono forniti con il cuscinetto schermato.

**N.B. Se in fase d'ordine la posizione di montaggio è omessa, il riduttore verrà fornito con i tappi predisposti per la posizione M1.**

B) Il tappo di sfiato è allegato solo nei riduttori che hanno più di un tappo olio.

C) Nei riduttori dove è necessario specificare la posizione di montaggio, la posizione richiesta è indicata nella targhetta del riduttore.

A) *When ordering size 90-110 worm gearboxes it is necessary to indicate the mounting position whether the worm gearbox is requested with oil or without lubricant. Particular attention should be paid to worm gearboxes with a shielded bearing mounted in positions M3 and M4.*

**N.B. If the mounting position is not specified in the order, the worm gearbox supplied will have plugs pre-arranged for position M1.**

B) *A breather plug is supplied only with worm gearboxes that have more than one oil plug.*

C) *The gearboxes that need a specific assembling position have the indication of it on the label of the gearbox.*

A) Für die Getriebe in den Baugrößen 90-110 muss in der Auftragsphase die Einbaulage verbindlich angegeben werden. Dies gilt sowohl für die Bestellung von mit Öl gefüllten Getrieben als auch für Getriebe ohne Ölfüllung. Besondere Aufmerksamkeit sollte den Getrieben zukommen, die in den Einbaulagen M3 und M4 montiert werden und mit abgeschirmtem Lager geliefert werden.

**Hinweis: Sollte in der Auftragsphase die Einbaulage nicht angegeben werden, wird das Getriebe mit Stopfen für die Einbaulage M1.**

B) Der Entlüftungsstopfen ist lediglich bei den Getrieben vorhanden, die über mehr als einen Ölfüllstopfen verfügen.

C) In den Getrieben in dem man die Montage Position angeben soll, findet man die angefragte Position auf dem Typenschild des Getriebes.

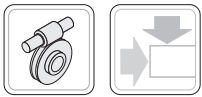

**1.5 Carichi radiali e assiali**

Quando la trasmissione del moto avviene tramite meccanismi che generano carichi radiali sull'estremità dell'albero, è necessario verificare che i valori risultanti non eccedono quelli indicati nelle tabelle.

Nella Tab. 2.5 sono riportati i valori dei carichi radiali ammissibili per l'albero veloce ( $Fr_1$ ). Come carico assiale ammissibile contemporaneo si ha:

$$Fa_1 = 0.2 \times Fr_1$$

Tab. 2.5



$n_1$ min <sup>-1</sup>	$Fr_1$ (N)					
	UI					
	40	50	63	75	90	110
2800	187	272	357	510	700	850
1400	220	320	420	600	800	1000
900	250	350	460	660	900	1200
700	280	400	500	730	1000	1300
500	310	450	530	800	1100	1450

In Tab. 2.7 sono riportati i valori dei carichi radiali ammissibili per l'albero lento ( $Fr_2$ ). Come carico assiale ammissibile contemporaneo si ha:

$$Fa_2 = 0.2 \times Fr_2$$

Tab. 2.7



$n_2$ min <sup>-1</sup>	$Fr_2$ (N)					
	UI - UMI					
	40	50	63	75	90	110
400	686	925	946	1400	1897	2168
280	808	1088	1114	1700	2232	2550
200	950	1280	1310	2000	2625	3000
140	1050	1450	1680	2300	2775	3150
93	1200	1620	1740	2600	3050	3600
70	1350	1850	1930	2800	3400	4150
50	1500	2100	2150	3400	4205	4850
35	1600	2230	2300	3700	4775	5700
29	1700	2400	2500	4100	5300	6200
25	1800	2580	2700	4300	5610	6600
20	1950	2700	2900	4700	6175	7200
18	2100	2850	3100	4900	6650	7800
14	2300	3200	3300	5200	7025	8250

A richiesta possono essere fornite versioni rinforzate con cuscinetti a rulli conici sulla corona in grado di sopportare carichi superiori a quelli ammessi dalle versioni normali.

Si veda a tal proposito la tabella 2.9, in cui sono riportati i valori dei carichi radiali e assiali ammissibili sull'albero uscita nel caso di cuscinetti conici sulla corona. Si consiglia, in questi casi, di adottare versioni flangiate, verificando che il carico assiale venga interamente assorbito dal cuscinetto alloggiato nella flangia di fissaggio.

**1.5 Axial and overhung loads**

*Should transmission movement determine radial loads on the angular shaft end, it is necessary to make sure that resulting values do not exceed the ones indicated in the tables.*

*In Table 2.5 permissible radial load for input shaft are listed ( $Fr_1$ ). Contemporary permissible axial load is given by the following formula:*

$$Fa_1 = 0.2 \times Fr_1$$

**1.5 Radiale und Axiale Belastungen**

Wird das Wellenende auch durch Radialkräfte belastet, so muß sichergestellt werden, daß die resultierenden Werte die in der Tabelle angegebenen nicht überschreiten.

In Tabelle 2.5 sind die Werte der zulässigen Radialbelastungen für die Antriebswelle ( $Fr_1$ ) angegeben. Die Axialbelastung beträgt dann:

$$Fa_1 = 0.2 \times Fr_1$$

*In Table 2.7 permissible radial loads for output shaft are listed ( $Fr_2$ ). Permissible axial load is given by the following formula:*

$$Fa_2 = 0.2 \times Fr_2$$

In Tabelle 2.7 sind die Werte der zulässigen Radialbelastungen für die Abtriebswelle angegeben.

Als zulässige Axialbelastung gilt:

$$Fa_2 = 0.2 \times Fr_2$$

*In order to increase the load capacity of the gearboxes it is possible to fit taper roller bearings on to the output shaft. Such reinforced versions are available upon request.*

*With regard to this reinforced version, let see output radial and axial load values shown on tab. 2.9. It's advisable to use flange mounted versions and to make sure that the axial load is absorbed by the bearing, housed in the fixing flange.*

Für größere Belastungen stehen auf Wunsch auch verstärkte Ausführungen mit Kegelrollenlagern für die Schneckenwelle zur Verfügung.

Tabelle 2.9 listet die zulässigen Radial- und Axiallasten bei Verwendung von Kegelrollenlagern auf. Es wird in diesen Fällen empfohlen, Flanschausführungen zu verwenden und sicherzustellen, daß die axiale Last vollständig vom Lager, das sich im Befestigungsflansch befindet, aufgenommen wird.



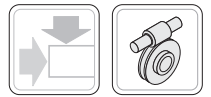

Tab. 2.9

**UI**  
**UMI**

CARICHI RADIALI - ASSIALI CON CUSCINETTI CONICI SULLA CORONA AXIAL AND OVERHUNG LOADS WITH TAPER ROLLER BEARINGS ON WORMWHEEL RADIALE UND AXIALE BELASTUNGEN MIT KEGELROLLENLAGERN AUF DEM SCHNECKENRAD												
n <sub>2</sub> (rpm)	UI - UMI											
	40		50		63		75		90		110	
	Fr <sub>2</sub>	Fa <sub>2</sub>	Fr <sub>2</sub>	Fa <sub>2</sub>	Fr <sub>2</sub>	Fa <sub>2</sub>	Fr <sub>2</sub>	Fa <sub>2</sub>	Fr <sub>2</sub>	Fa <sub>2</sub>	Fr <sub>2</sub>	Fa <sub>2</sub>
400	2076	2708	4603	5325	4693	5415	5415	6588	6543	8529	7671	9837
280	2185	2850	4845	5605	4940	5700	5700	6935	6888	8978	8075	10355
200	2300	3000	5100	5900	5200	6000	6000	7300	7250	9450	8500	10900
140	2300	3000	5600	6500	5750	6650	6700	8200	7900	10300	9200	11800
93	2300	3000	6300	7300	6500	7550	7500	9150	8400	10950	9200	11800
70	2300	3000	6550	7600	6200	7200	7600	9300	7850	10225	9200	11800
50	2300	3000	6900	8000	6900	8000	8700	10600	9250	12050	10600	13600
35	2300	3000	6900	8000	6900	8000	9000	11000	11450	14900	13900	13600
29	2300	3000	6900	8000	6900	8000	9000	11000	11900	15500	14800	17800
25	2300	3000	6900	8000	6900	8000	9000	11000	11900	15500	14800	19000
20	2300	3000	6900	8000	6900	8000	9000	11000	11900	15500	14800	19000
18	2300	3000	6900	8000	6900	8000	9000	11000	11900	15500	14800	19000

I carichi radiali indicati nelle tabelle si intendono applicati a metà della sporgenza dell'albero e sono riferiti ai riduttori operanti con fattore di servizio 1.

Valori intermedi relativi a velocità non riportate possono essere ottenuti per interpolazione considerando però che Fr<sub>1</sub> a 500 min<sup>-1</sup> e Fr<sub>2</sub> a 14 min<sup>-1</sup> rappresentano i carichi massimi consentiti.

Per i carichi non agenti sulla mezzeria dell'albero lento o veloce si ha:

a 0.3 della sporgenza:

$$F_{rx} = 1.25 \times Fr_{1-2}$$

a 0.8 dalla sporgenza:

$$F_{rx} = 0.8 \times Fr_{1-2}$$

The radial loads shown in the tables are applied on the centre line of the shaft extension and are related to gearboxes working with service factor 1.

Intermediate values of speeds that are not listed can be obtained through interpolation but it must be considered that Fr<sub>1</sub> at 500 min<sup>-1</sup> and Fr<sub>2</sub> at 14 min<sup>-1</sup> represent the maximum allowable loads.

For loads which are not applied on the centre line of the output or input shaft, following values will be obtained:

at 0.3 from extension:

$$F_{rx} = 1.25 \times Fr_{1-2}$$

at 0.8 from extension:

$$F_{rx} = 0.8 \times Fr_{1-2}$$

Bei den in der Tabelle angegebenen Radialbelastungen wird eine Kräfteinwirkung auf die Mitte des Wellenendes zugrunde gelegt; außerdem arbeiten die Getriebe mit Betriebsfaktor 1. Zwischenwerte für nicht aufgeführte Drehzahlen können durch Interpolation ermittelt werden. Hierbei ist jedoch zu berücksichtigen, daß die Werte von Fr<sub>1</sub> bei 500 min<sup>-1</sup> und von Fr<sub>2</sub> bei 14 min<sup>-1</sup> die Maximalbelastungen repräsentieren. Bei Lasten, die nicht auf die Mitte der Ab- bzw. Antriebswellen wirken, legt man folgende Werte zugrunde:

0.3 vom Wellenabsatz:

$$F_{rx} = 1.25 \times Fr_{1-2}$$

0.8 vom Wellenabsatz:

$$F_{rx} = 0.8 \times Fr_{1-2}$$

Tab. 2.11

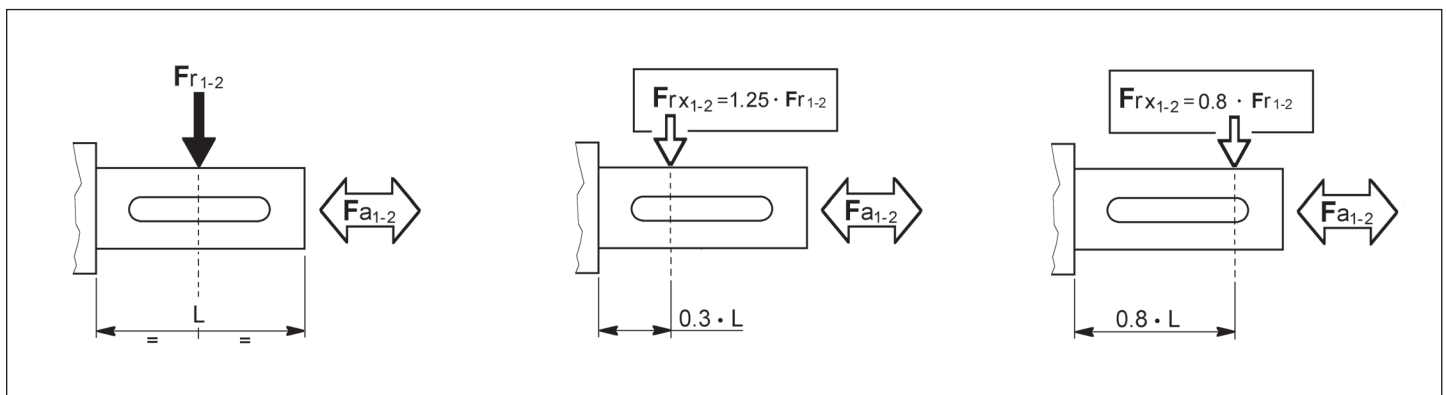



## UI 40



2.1

ir	$n_1 = 2800 \text{ min}^{-1}$				$n_1 = 1400 \text{ min}^{-1}$				$n_1 = 900 \text{ min}^{-1}$				$n_1 = 500 \text{ min}^{-1}$				IEC
	$n_2$ $\text{min}^{-1}$	$T_{2M}$ Nm	P kW	RD %	$n_2$ $\text{min}^{-1}$	$T_{2M}$ Nm	P kW	RD %	$n_2$ $\text{min}^{-1}$	$T_{2M}$ Nm	P kW	RD %	$n_2$ $\text{min}^{-1}$	$T_{2M}$ Nm	P kW	RD %	
7	400	27	1.3	84	200	37	0.93	83	129	44	0.73	81	71	54	0.50	80	71-63-56
10	280	31	1.1	83	140	42	0.76	81	90	49	0.58	79	50	59	0.40	78	
15	187	32	0.78	80	93	42	0.53	77	60	49	0.41	75	33	59	0.28	73	
20	140	29	0.56	76	70	37	0.37	73	45	43	0.29	70	25	51	0.20	67	
28	100	34	0.50	71	50	43	0.34	67	32	50	0.26	64	17.9	59	0.18	61	
40	70	32	0.36	65	35	40	0.24	60	23	45	0.19	56	12.5	53	0.13	53	
49	57	30	0.29	62	29	38	0.20	57	18.4	43	0.16	53	10.2	50	0.11	49	
56	50	28	0.24	60	25	36	0.17	54	16.1	40	0.13	51	8.9	47	0.09	47	
70	40	23	0.18	53	20	28	0.12	47	12.9	32	0.10	44	7.1	37	0.07	39	
80	35	21	0.15	50	17.5	26	0.11	44	11.3	29	0.09	40	6.3	34	0.06	36	
100	28	23	0.13	51	14.0	28	0.09	45	9.0	30	0.07	41	5.0	31	0.04	38	

## UI 50



3.5

ir	$n_1 = 2800 \text{ min}^{-1}$				$n_1 = 1400 \text{ min}^{-1}$				$n_1 = 900 \text{ min}^{-1}$				$n_1 = 500 \text{ min}^{-1}$				IEC
	$n_2$ $\text{min}^{-1}$	$T_{2M}$ Nm	P kW	RD %	$n_2$ $\text{min}^{-1}$	$T_{2M}$ Nm	P kW	RD %	$n_2$ $\text{min}^{-1}$	$T_{2M}$ Nm	P kW	RD %	$n_2$ $\text{min}^{-1}$	$T_{2M}$ Nm	P kW	RD %	
7	400	50	2.5	85	200	68	1.7	84	129	81	1.3	83	71	100	0.91	82	80-71-63
10	280	55	1.9	84	140	73	1.3	82	90	86	1.0	81	50	105	0.70	79	
15	187	58	1.4	82	93	76	0.93	80	60	89	0.71	79	33	106	0.48	77	
20	140	57	1.1	79	70	74	0.71	76	45	86	0.55	74	25	102	0.38	71	
28	100	62	0.88	74	50	80	0.60	70	32	92	0.46	67	17.9	109	0.32	64	
40	70	64	0.67	70	35	81	0.45	66	23	92	0.34	63	12.5	108	0.24	59	
49	57	57	0.51	67	29	72	0.34	63	18.4	82	0.27	59	10.2	96	0.19	55	
56	50	55	0.44	65	25	69	0.30	60	16.1	78	0.23	56	8.9	91	0.16	53	
70	40	52	0.36	61	20	64	0.24	56	12.9	72	0.19	52	7.1	84	0.13	48	
80	35	47	0.30	57	17.5	58	0.21	51	11.3	66	0.17	47	6.3	75	0.11	43	
100	28	42	0.23	54	14.0	52	0.16	48	9.0	59	0.13	44	5.0	60	0.08	40	

## UI 63



6.0

ir	$n_1 = 2800 \text{ min}^{-1}$				$n_1 = 1400 \text{ min}^{-1}$				$n_1 = 900 \text{ min}^{-1}$				$n_1 = 500 \text{ min}^{-1}$				IEC
	$n_2$ $\text{min}^{-1}$	$T_{2M}$ Nm	P kW	RD %	$n_2$ $\text{min}^{-1}$	$T_{2M}$ Nm	P kW	RD %	$n_2$ $\text{min}^{-1}$	$T_{2M}$ Nm	P kW	RD %	$n_2$ $\text{min}^{-1}$	$T_{2M}$ Nm	P kW	RD %	
7	400	84	4.1	86	200	115	2.9	84	129	137	2.2	84	71	169	1.5	83	90-80-71
10	280	93	3.2	84	140	126	2.2	83	90	149	1.7	81	50	182	1.2	80	
15	187	98	2.3	82	93	131	1.6	80	60	153	1.2	78	33	184	0.85	76	
20	140	104	1.9	80	70	136	1.3	77	45	158	0.99	75	25	189	0.69	72	
28	100	105	1.5	75	50	135	1.0	71	32	156	0.77	68	17.9	186	0.54	65	
40	70	113	1.2	71	35	145	0.79	67	23	166	0.61	64	12.5	195	0.43	60	
49	57	98	0.85	69	29	125	0.58	64	18.4	142	0.45	61	10.2	166	0.31	57	
56	50	101	0.79	67	25	127	0.54	62	16.1	145	0.42	58	8.9	169	0.29	54	
70	40	94	0.62	63	20	117	0.42	58	12.9	133	0.33	54	7.1	154	0.23	50	
80	35	88	0.53	61	17.5	110	0.37	55	11.3	124	0.29	51	6.3	144	0.20	47	
100	28	80	0.41	57	14.0	99	0.28	51	9.0	112	0.22	47	5.0	125	0.15	43	

## UI 75



9.0

ir	$n_1 = 2800 \text{ min}^{-1}$				$n_1 = 1400 \text{ min}^{-1}$				$n_1 = 900 \text{ min}^{-1}$				$n_1 = 500 \text{ min}^{-1}$				IEC
	$n_2$ $\text{min}^{-1}$	$T_{2M}$ Nm	P kW	RD %	$n_2$ $\text{min}^{-1}$	$T_{2M}$ Nm	P kW	RD %	$n_2$ $\text{min}^{-1}$	$T_{2M}$ Nm	P kW	RD %	$n_2$ $\text{min}^{-1}$	$T_{2M}$ Nm	P kW	RD %	
7	400	146	7.11	86	200	205	5.05	85	129	241	3.86	84	71	298	2.69	83	100-112 <sup>(1)</sup> 90-80
10	280	163	5.66	85	140	220	3.86	84	90	261	2.98	83	50	320	2.08	81	
15	187	173	4.12	82	93	230	2.79	81	60	270	2.16	79	33	325	1.48	77	
20	140	161	2.93	81	70	220	2.07	78	45	245	1.52	76	25	293	1.05	73	
28	100	193	2.71	75	50	255	1.87	72	32	290	1.42	69	18	345	1.00	65	
40	70	176	1.80	72	35	230	1.24	68	23	258	0.94	65	13	303	0.65	61	
49	57	169	1.47	69	29	220	1.02	65	18	245	0.77	61	10	287	0.54	57	
56	50	153	1.17	69	25	200	0.82	64	16	219	0.61	60	9	256	0.43	56	
70	40	153	1.00	64	20	195	0.69	59	13	217	0.53	56	7	252	0.37	51	
80	35	145	0.86	62	18	185	0.61	56	11	205	0.46	52	6	237	0.32	48	
100	28	131	0.66	59	14	170	0.48	52	9	183	0.36	49	5	206	0.25	44	



## UI 90



14.0

ir	$n_1 = 2800 \text{ min}^{-1}$				$n_1 = 1400 \text{ min}^{-1}$				$n_1 = 900 \text{ min}^{-1}$				$n_1 = 500 \text{ min}^{-1}$				IEC
	$n_2$ min <sup>-1</sup>	$T_{2M}$ Nm	P kW	RD %	$n_2$ min <sup>-1</sup>	$T_{2M}$ Nm	P kW	RD %	$n_2$ min <sup>-1</sup>	$T_{2M}$ Nm	P kW	RD %	$n_2$ min <sup>-1</sup>	$T_{2M}$ Nm	P kW	RD %	
7	400	230	11,2	86	200	320	7,8	86	129	382	6,1	85	71	474	4,2	84	100-112 <sup>(1)</sup> 90-80
10	280	255	8,8	85	140	347	6,0	85	90	412	4,6	84	50	505	3,2	82	
15	187	278	6,6	83	93	371	4,4	82	60	436	3,4	80	33	526	2,4	78	
20	140	290	5,2	82	70	381	3,5	80	45	444	2,7	78	25	531	1,9	75	
28	100	318	4,4	76	50	414	2,9	74	32	480	2,3	71	18	572	1,6	67	
40	70	316	3,2	73	35	406	2,1	71	23	466	1,6	67	13	550	1,1	64	
49	57	290	2,4	71	29	368	1,6	67	18	421	1,3	64	10	494	0,9	60	
56	50	272	2,0	71	25	344	1,3	68	16	392	1,0	63	9	458	0,7	59	
70	40	246	1,5	67	20	309	1,0	63	13	350	0,8	59	7	408	0,6	54	
80	35	238	1,4	65	18	297	0,9	60	11	336	0,7	56	6	390	0,5	52	
100	28	217	1,1	61	14	270	0,7	55	9	296	0,5	52	5	313	0,4	47	

## UI 110



35.0

ir	$n_1 = 2800 \text{ min}^{-1}$				$n_1 = 1400 \text{ min}^{-1}$				$n_1 = 900 \text{ min}^{-1}$				$n_1 = 500 \text{ min}^{-1}$				IEC
	$n_2$ min <sup>-1</sup>	$T_{2M}$ Nm	P kW	RD %	$n_2$ min <sup>-1</sup>	$T_{2M}$ Nm	P kW	RD %	$n_2$ min <sup>-1</sup>	$T_{2M}$ Nm	P kW	RD %	$n_2$ min <sup>-1</sup>	$T_{2M}$ Nm	P kW	RD %	
7	400	341	16.6	86	200	478	11.6	86	129	577	9.1	85	71	720	6.4	84	132 <sup>(1)</sup> 112-100-90
10	280	391	13.5	85	140	537	9.3	85	90	640	7.2	84	50	788	5.0	82	
15	187	396	9.3	83	93	535	6.4	82	60	632	5.0	80	33	769	3.4	78	
20	140	465	8.3	82	70	617	5.6	81	45	722	4.3	79	25	869	3.0	76	
28	100	433	5.9	77	50	570	4.0	75	32	665	3.1	72	17.9	796	2.2	69	
40	70	493	4.9	74	35	638	3.2	72	23	737	2.6	68	12.5	873	1.8	65	
49	57	452	3.8	72	29	581	2.5	69	18.4	667	1.9	66	10.2	786	1.4	62	
56	50	364	2.7	71	25	465	1.8	69	16.1	532	1.4	64	8.9	624	0.97	60	
70	40	381	2.3	68	20	483	1.6	64	12.9	551	1.2	60	7.1	644	0.88	55	
80	35	390	2.2	66	17.5	491	1.5	62	11.3	559	1.1	58	6.3	651	0.80	53	
100	28	355	1.7	62	14.0	444	1.1	57	9.0	503	0.89	53	5.0	583	0.62	49	

**ATTENZIONE!**

Per situazioni con velocità di ingresso particolari attenersi alla tabella sotto riportata che evidenzia situazioni critiche per ogni riduttore (Vedere paragrafo 1.2-A).

**WARNING!**

*If in presence of non standard input speed please attain to the chart below considering extreme usage conditions for each gearbox (Look at chapter 1.2-A).*

**ACHTUNG!**

Mit unstandardisierte Antriebsgeschwindigkeit bitte auf folgende Liste Bezug nehmen in Betrachtung der schwierigen Arbeitsbedingungen fuer jede Getriebe (s. S. 1.2-A).

	UI - RI													
	28	40	50	63	70	75	85	90	110	130	150	180		
$1500 < n_1 < 3000$	OK	OK	OK	<b>Contattare il ns. servizio tecnico Contact our technical dept Wenden Sie sich an unseren technischen Service</b>										
$n_1 > 3000$														

<sup>(1)</sup> **ATTENZIONE!**

Linguette a disegno STM.  
(Vedere paragrafo 1.11-A).

<sup>(1)</sup> **WARNING!**

*(Look at chapter 1.11-A).*

<sup>(1)</sup> **ACHTUNG!**

*(s. S. 1.11-A).*

I pesi riportati sono indicativi e possono variare in funzione della versione del riduttore.

*Listed weights are for reference only and can vary according to the gearbox version.*

Die angegebenen Gewichte sind Richtwerte und können je nach Getriebeversion etwas variieren.

N.B. Per i riduttori evidenziati dal doppio bordo nella colonna delle potenze è necessario verificare lo scambio termico del riduttore (come nel par. 1.7-A). Per maggiori informazioni contattare l'ufficio tecnico STM.

**NOTE.** Please pay attention to the frame around the input power value: for this gearboxes it's important to check the thermal capacity (comp. chapter 1.7-A). For details please contact our technical department.

**HINWEIS.** Sind in den Tabellen Nennleistungen eingerahmt, so ist die thermische Leistungsgrenze der Getriebe zu beachten (s. S. 1.7-A). Für weitere Informationen wenden Sie sich bitte an unser technisches Büro.



Nella tab. 2.6 sono riportate le dimensioni IEC e le possibili combinazioni albero/flangia riduttore predisposto per accoppiamento motore.

In table 2.6 are listed the IEC dimensions as well as the possible shaft/flange combinations of the gearbox to be coupled with a motor.

In Tabelle 2.6 sind sowohl die IEC-Anschlußmaße als auch weitere mögliche Welle/Flansch-Kombinationen zur Motorbefestigung aufgeführt.

Tab. 2.6

Possibili accoppiamenti con motori IEC / Possible couplings with IEC motors / Mögliche Verbindungen mit IEC-Motoren.											
	IEC	ir									
		7	10	15	20	28	40	49	56	70	80
UMI 40	71 <sup>(1)</sup>	14/160 (B5) - 14/105 (B14) - 14/140 - 14/120 - 14/90•									
	63	11/140 (B5) - 11/90• (B14) - 11/160 - 11/120 - 11/105									
	56	9/120 (B5) - 9/160 - 9/140 - 9/105 - 9/90•									
UMI 50	80 <sup>(1)</sup>	19/120 (B14) - 19/200 (B5) - 19/160 - 19/140 - 19/105• - 19/90•									
	71	14/160 (B5) - 14/105• (B14) - 14/200 - 14/140 - 14/120 - 14/90•									
	63	11/140 (B5) - 11/90• (B14) - 11/200 - 11/160 - 11/120 - 11/105•									
UMI 63	90 <sup>(1)</sup>	24/200 (B5) - 24/140 (B14) - 24/160 - 24/120 - 24/105•									
	80	19/200 (B5) - 19/120 (B14) - 19/160 - 19/140 - 19/105•									
	71	14/160 (B5) - 14/105• (B14) - 14/200 - 14/140 - 14/120									
UMI 75	112 <sup>(1)</sup>	28/250 (B5) - 28/160 (B14) 28/140									
	100 <sup>(1)</sup>	28/250 (B5) - 28/160 (B14) 28/140									
	90	24/200 (B5) - 24/140 (B14) - 24/250 - 24/160 - 24/120									
	80	19/200 (B5) - 19/120 (B14) - 19/250 - 19/160 - 19/140									
UMI 90	112 <sup>(1)</sup>	28/250 (B5) - 28/160 (B14)									
	100 <sup>(1)</sup>	28/250 (B5) - 28/160 (B14)									
	90	24/200 (B5) - 24/140 (B14) - 24/250 - 24/160 - 24/120									
	80	19/200 (B5) - 19/120 (B14) - 19/250 - 19/160 - 19/140									
UMI 110	132 <sup>(1)</sup>	38/300 (B5) - 38/250 - 38/160									
	112	28/250 (B5) - 28/160 (B14) - 28/200 - 28/300									
	100	28/250 (B5) - 28/160 (B14) - 28/200 - 28/300									
	90	24/200 (B5) - 24/250 - 24/160 - 24/300									

**(1) ATTENZIONE!**

Linguette a disegno STM.  
(Vedere paragrafo 1.11-A).

**(1) WARNING!**

(Look at chapter 1.11-A).

**(1) ACHTUNG!**

(s. S. 1.11-A).

Legenda:

11/140 (B5)

11/120

11/140 : combinazioni albero/flangia standard (B5) : forma costruttiva motore IEC  
11/120 : combinazioni albero/flangia a richiesta

Key:

11/140 (B5)

11/120

11/140 : standard shaft/flange combination (B5) : IEC motor constructive shape  
11/120 : shaft/flange combinations upon request

Legende:

11/140 (B5)

11/120

11/140 : Standardkombinationen Welle/Flansch (B5) : Konstruktionsform IEC-Motor  
11/120 : Sonderkombinationen Welle/Flansch

**N.B.**

La configurazione standard della flangia attacco motore prevede 4 fori a 45° (esempio x: vedi par. 1.3).

Per le flange contrassegnate con il simbolo (•) i fori per il fissaggio al motore sono disposti in croce (esempio +). Pertanto è opportuno valutare l'ingombro della morsettiera del motore che verrà installato in quanto essa verrà a trovarsi orientata a 45° rispetto agli assi. Per la scelta della posizione della morsettiera rispetto agli assi fare riferimento allo schema seguente (in cui la posizione 5 è quella standard):

**Note.**

The standard configuration for the 4 holes is 45° to the axles (like an x: see par. 1.3).

For the B14 flanges marked with (•) the holes to fit the motor are on the axles (like a +). Therefore we suggest to check the dimensions of the terminal board of the motor as it will be at 45° to the axles. Please, choose the terminal board position referring to the following sketch (in which N° 5 is the standard position):

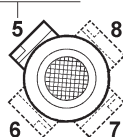
**STANDARD****HINWEIS.**

In der Standardkonfiguration sind die 4 Flanschbohrungen im 45°-Winkel zu den Achsen angeordnet (wie ein x: siehe kapitel 1.3).

Bei B14-Flanschen, die mit (•) gekennzeichnet sind, sind die Bohrungen auf den Achsen angeordnet (wie ein +). Es sollte deshalb der Platzbedarf des Motorklemmenkastens beachtet werden, da er sich in 45°-Position zu den Achsen befinden wird. Die Lage des Klemmenkastens des Motors wählen Sie bitte anhand der folgenden Skizze (Pos.5 ist Standardposition):



1.7 Prestazioni motoriduttori

1.7 Gearmotors performances

1.7 Leistungen der Getriebemotoren

$n_2$ min <sup>-1</sup>	ir	T2 Nm	FS'		
----------------------------	----	----------	-----	--	--

<b>0.09 kW</b>	$n_1 = 2740 \text{ min}^{-1}$	56A 2
	$n_1 = 1360 \text{ min}^{-1}$	56B 4
	$n_1 = 860 \text{ min}^{-1}$	63B 6

49	28	12	3.6	UMI 40	56B 4
43	20	14	3.1	UMI 40	63B 6
34	40	15	2.6	UMI 40	56B 4
31	28	18	2.8	UMI 40	63B 6
28	49	18	2.2	UMI 40	56B 4
24	56	19	1.9	UMI 40	56B 4
19.4	70	21	1.3	UMI 40	56B 4
17.0	80	22	1.2	UMI 40	56B 4
15.4	56	29	1.4	UMI 40	63B 6
13.6	100	28	1.0	UMI 40	56B 4
12.3	70	31	1.0	UMI 40	63B 6

<b>0.11 kW</b>	$n_1 = 1360 \text{ min}^{-1}$	56C 4
----------------	-------------------------------	-------

68	20	11	3.3	UMI 40	56C 4
49	28	14	3.0	UMI 40	56C 4
34	40	19	2.2	UMI 40	56C 4
28	49	22	1.8	UMI 40	56C 4
24	56	23	1.5	UMI 40	56C 4
19.4	70	25	1.1	UMI 40	56C 4
17.0	80	27	1.0	UMI 40	56C 4
13.6	100	35	0.8	UMI 40	56C 4

<b>0.13 kW</b>	$n_1 = 2750 \text{ min}^{-1}$	56B 2
	$n_1 = 1360 \text{ min}^{-1}$	63A 4
	$n_1 = 860 \text{ min}^{-1}$	63C 6

393	7	3	10.2	UMI 40	56B 2
393	7	3	9.8	UMI 40	56B 2
275	10	4	8.3	UMI 40	56B 2
275	10	4	8.0	UMI 40	56B 2
194	7	5	7.0	UMI 40	63A 4
136	10	7	5.7	UMI 40	63A 4
91	15	11	4.0	UMI 40	63A 4
68	20	13	2.8	UMI 40	63A 4
56	49	14	2.2	UMI 40	56B 2
56	49	14	2.1	UMI 40	56B 2
49	28	17	2.5	UMI 40	63A 4
34	40	24	3.4	UMI 50	63A 4
34	40	22	1.8	UMI 40	63A 4
28	49	28	2.6	UMI 50	63A 4
28	49	25	1.5	UMI 40	63A 4
24	56	31	2.2	UMI 50	63A 4
24	56	28	1.3	UMI 40	63A 4
22	40	36	2.5	UMI 50	63C 6
22	40	32	1.4	UMI 40	63C 6
19.4	70	36	1.8	UMI 50	63A 4
19.4	70	30	0.9	UMI 40	63A 4
17.0	80	37	1.6	UMI 50	63A 4
17.0	80	32	0.8	UMI 40	63A 4
13.6	100	44	1.2	UMI 50	63A 4
12.3	70	53	1.4	UMI 50	63C 6
8.6	100	64	0.9	UMI 50	63C 6

$n_2$ min <sup>-1</sup>	ir	T2 Nm	FS'		
----------------------------	----	----------	-----	--	--

<b>0.18 kW</b>	$n_1 = 2760 \text{ min}^{-1}$	63A 2
	$n_1 = 1370 \text{ min}^{-1}$	63B 4
	$n_1 = 870 \text{ min}^{-1}$	71A 6

394	7	4	7.4	UMI 40	63A 2
276	10	5	6.0	UMI 40	63A 2
196	7	7	5.1	UMI 40	63B 4
137	10	10	4.1	UMI 40	63B 4
124	7	11	3.9	UMI 40	71A 6
91	15	14	2.9	UMI 40	63B 4
69	20	18	2.0	UMI 40	63B 4
58	15	22	2.2	UMI 40	71A 6
49	28	25	3.3	UMI 50	63B 4
49	28	24	1.8	UMI 40	63B 4
44	20	29	2.9	UMI 50	71A 6
44	20	28	1.6	UMI 40	71A 6
34	40	33	2.4	UMI 50	63B 4
34	40	30	1.3	UMI 40	63B 4
28	49	39	1.9	UMI 50	63B 4
28	49	35	1.1	UMI 40	63B 4
24	56	42	1.6	UMI 50	63B 4
24	56	38	0.9	UMI 40	63B 4
19.6	70	49	1.3	UMI 50	63B 4
17.1	80	51	1.1	UMI 50	63B 4
15.5	56	64	2.3	UMI 63	71A 6
15.5	56	62	1.3	UMI 50	71A 6
13.7	100	60	0.9	UMI 50	63B 4
12.4	70	75	1.8	UMI 63	71A 6
12.4	70	72	1.0	UMI 50	71A 6
10.9	80	81	1.5	UMI 63	71A 6
10.9	80	74	0.9	UMI 50	71A 6
8.7	100	93	1.2	UMI 63	71A 6

<b>0.22 kW</b>	$n_1 = 1400 \text{ min}^{-1}$	63C 4
----------------	-------------------------------	-------

200	7	9	4.2	UMI 40	63C 4
140	10	12	3.5	UMI 40	63C 4
93	15	17	2.4	UMI 40	63C 4
70	20	22	1.7	UMI 40	63C 4
50	28	29	2.7	UMI 50	63C 4
50	28	28	1.5	UMI 40	63C 4
35	40	40	2.0	UMI 50	63C 4
35	40	36	1.1	UMI 40	63C 4
29	49	46	1.6	UMI 50	63C 4
29	49	42	0.9	UMI 40	63C 4
25	56	50	1.4	UMI 50	63C 4
20	70	59	1.1	UMI 50	63C 4
17.5	80	61	0.9	UMI 50	63C 4

$n_2$ min <sup>-1</sup>	ir	T2 Nm	FS'		
----------------------------	----	----------	-----	--	--

<b>0.25 kW</b>	$n_1 = 2790 \text{ min}^{-1}$	63B 2
	$n_1 = 1370 \text{ min}^{-1}$	71A 4
	$n_1 = 870 \text{ min}^{-1}$	71B 6

399	7	5	5.4	UMI 40	63B 2
399	7	5	5.4	UMI 40	63B 2
279	10	7	4.4	UMI 40	63B 2
196	7	10	6.6	UMI 50	71A 4
196	7	10	3.7	UMI 40	71A 4
137	10	14	5.1	UMI 50	71A 4
137	10	14	3.0	UMI 40	71A 4
124	7	16	5.1	UMI 50	71B 6
124	7	16	2.8	UMI 40	71B 6
91	15	21	3.6	UMI 50	71A 4
91	15	20	2.1	UMI 40	71A 4
69	20	26	2.8	UMI 50	71A 4
69	20	25	1.5	UMI 40	71A 4
58	15	33	2.7	UMI 50	71B 6
58	15	31	1.6	UMI 40	71B 6
49	28	34	2.3	UMI 50	71A 4
49	28	33	1.3	UMI 40	71A 4
44	20	41	2.1	UMI 50	71B 6
44	20	38	1.1	UMI 40	71B 6
34	40	47	3.1	UMI 63	71A 4
34	40	46	1.8	UMI 50	71A 4
31	28	52	3.0	UMI 63	71B 6
31	28	51	1.8	UMI 50	71B 6
31	28	49	1.0	UMI 40	71B 6
28	49	55	2.3	UMI 63	71A 4
28	49	54	1.3	UMI 50	71A 4
24	56	61	2.1	UMI 63	71A 4
24	56	59	1.2	UMI 50	71A 4
22	40	70	2.4	UMI 63	71B 6
22	40	69	1.3	UMI 50	71B 6
19.6	70	71	1.7	UMI 63	71A 4
19.6	70	68	0.9	UMI 50	71A 4
17.1	80	77	1.4	UMI 63	71A 4
17.1	80	71	0.8	UMI 50	71A 4
15.5	56	89	1.6	UMI 63	71B 6
15.5	56	86	0.9	UMI 50	71B 6
13.7	100	89	1.1	UMI 63	71A 4
12.4	70	104	1.3	UMI 63	71B 6

<b>0.37 kW</b>	$n_1 = 2790 \text{ min}^{-1}$	63C 2
	$n_1 = 2790 \text{ min}^{-1}$	71A 2
	$n_1 = 1380 \text{ min}^{-1}$	71B 4
	$n_1 = 910 \text{ min}^{-1}$	80A 6

399	7	7	3.6	UMI 40	71A 2
399	7	7	3.6	UMI 40	63C 2
279	10	11	2.9	UMI 40	71A 2
279	10	11	2.9	UMI 40	63C 2
197	7	15	4.5	UMI 50	71B 4
197	7	15	2.5	UMI 40	71B 4
186	15	16	3.7	UMI 50	71A 2
186	15	15	2.1	UMI 40	71A 2
186	15	15	2.1	UMI 40	63C 2
140	20	20	2.8	UMI 50	71A 2
140	20	19	1.5	UMI 40	71A 2



## 1.7 Prestazioni motoriduttori

## 1.7 Gearmotors performances

## 1.7 Leistungen der Getriebemotoren

$n_2$ min <sup>-1</sup>	ir	T2 Nm	FS'		
----------------------------	----	----------	-----	--	--

0.37 kW

 $n_1 = 2790 \text{ min}^{-1}$   
 $n_1 = 2790 \text{ min}^{-1}$   
 $n_1 = 1380 \text{ min}^{-1}$   
 $n_1 = 910 \text{ min}^{-1}$ 
63C 2  
71A 2  
71B 4  
80A 6

140	20	19	1.5	UMI 40	63C 2
138	10	21	3.5	UMI 50	71B 4
138	10	21	2.0	UMI 40	71B 4
92	15	31	2.5	UMI 50	71B 4
92	15	30	1.4	UMI 40	71B 4
61	15	46	5.7	UMI 75	80A 6
69	20	39	3.4	UMI 63	71B 4
69	20	39	1.9	UMI 50	71B 4
69	20	37	1.0	UMI 40	71B 4
49	28	51	2.7	UMI 63	71B 4
49	28	50	1.6	UMI 50	71B 4
49	28	48	0.9	UMI 40	71B 4
35	40	69	2.1	UMI 63	71B 4
45	20	60	3.9	UMI 75	80A 6
35	40	68	1.2	UMI 50	71B 4
33	28	76	3.7	UMI 75	80A 6
28	49	80	1.6	UMI 63	71B 4
28	49	79	0.9	UMI 50	71B 4
25	56	89	1.4	UMI 63	71B 4
25	56	86	0.8	UMI 50	71B 4
23	40	104	4.5	UMI 90	80A 6
23	40	104	2.4	UMI 75	80A 6
20	70	104	1.1	UMI 63	71B 4
19	49	122	3.5	UMI 90	80A 6
19	49	120	2.0	UMI 75	80A 6
17	80	113	1.0	UMI 63	71B 4
16	56	137	2.9	UMI 90	80A 6
16	56	135	1.6	UMI 75	80A 6
13	70	160	2.2	UMI 90	80A 6
13	70	155	1.4	UMI 75	80A 6
11	80	174	1.9	UMI 90	80A 6
11	80	171	1.2	UMI 75	80A 6
9	100	202	1.5	UMI 90	80A 6
9	100	198	0.9	UMI 75	80A 6

0.55 kW

 $n_1 = 2800 \text{ min}^{-1}$   
 $n_1 = 1380 \text{ min}^{-1}$   
 $n_1 = 1390 \text{ min}^{-1}$   
 $n_1 = 910 \text{ min}^{-1}$ 
71B 2  
71C 4  
80A 4  
80B 6

400	7	11	4.5	UMI 50	71B 2
400	7	11	2.4	UMI 40	71B 2
280	10	16	3.5	UMI 50	71B 2
280	10	16	2.0	UMI 40	71B 2
199	7	22	3.1	UMI 50	80A 4
197	7	22	3.0	UMI 50	71C 4
197	7	22	1.7	UMI 40	71C 4
187	15	23	1.4	UMI 40	71B 2
140	20	29	1.0	UMI 40	71B 2
139	10	32	7.0	UMI 75	80A 4
139	10	31	2.4	UMI 50	80A 4
138	10	31	2.3	UMI 50	71C 4
138	10	31	1.4	UMI 40	71C 4
130	7	34	7.0	UMI 75	80B 6

$n_2$ min <sup>-1</sup>	ir	T2 Nm	FS'		
----------------------------	----	----------	-----	--	--

0.55 kW

 $n_1 = 2800 \text{ min}^{-1}$   
 $n_1 = 1380 \text{ min}^{-1}$   
 $n_1 = 1390 \text{ min}^{-1}$   
 $n_1 = 910 \text{ min}^{-1}$ 
71B 2  
71C 4  
80A 4  
80B 6

130	7	34	2.4	UMI 50	80B 6
100	28	39	2.7	UMI 63	71B 2
100	28	39	1.6	UMI 50	71B 2
93	15	46	5.0	UMI 75	80A 4
93	15	45	2.9	UMI 63	80A 4
93	15	45	1.7	UMI 50	80A 4
92	15	46	1.7	UMI 50	71C 4
92	15	44	1.0	UMI 40	71C 4
70	20	60	3.7	UMI 75	80A 4
70	20	58	2.3	UMI 63	80A 4
70	20	57	1.3	UMI 50	80A 4
69	20	58	1.3	UMI 50	71C 4
61	15	69	6.3	UMI 90	80B 6
61	15	68.4	3.8	UMI 75	80B 6
50	28	78	5.3	UMI 90	80A 4
50	28	76	3.3	UMI 75	80A 4
50	28	75	1.8	UMI 63	80A 4
50	28	74	1.1	UMI 50	80A 4
49	28	76	1.8	UMI 63	71C 4
49	28	75	1.1	UMI 50	71C 4
46	20	90	4.9	UMI 90	80B 6
46	20	88	2.6	UMI 75	80B 6
46	20	87	1.8	UMI 63	80B 6
46	20	85	1.0	UMI 50	80B 6
35	40	107	3.8	UMI 90	80A 4
35	40	102	2.2	UMI 75	80A 4
35	40	101	1.4	UMI 63	80A 4
35	40	102	1.4	UMI 63	71C 4
35	40	100	0.8	UMI 50	71C 4
28	49	124	3.0	UMI 90	80A 4
28	49	120	1.8	UMI 75	80A 4
28	49	119	1.1	UMI 63	80A 4
28	49	119	1.0	UMI 63	71C 4
25	56	144	2.4	UMI 90	80A 4
25	56	138	1.5	UMI 75	80A 4
25	56	131	1.0	UMI 63	80A 4
25	56	132	1.0	UMI 63	71C 4
20	70	167	1.9	UMI 90	80A 4
20	70	161	1.2	UMI 75	80A 4
19	49	181	2.3	UMI 90	80B 6
19	49	178	1.4	UMI 75	80B 6
17	80	181	1.6	UMI 90	80A 4
17	80	178	1.0	UMI 75	80A 4
16	56	204	1.9	UMI 90	80B 6
16	56	200	1.0	UMI 75	80B 6
14	100	208	1.3	UMI 90	80A 4
14	100	208	0.8	UMI 75	80A 4
13	70	238	1.5	UMI 90	80B 6
13	70	230	0.9	UMI 75	80B 6
11	80	259	1.3	UMI 90	80B 6
11	80	254	0.8	UMI 75	80B 6
9	100	300	1.0	UMI 90	80B 6

$n_2$ min <sup>-1</sup>	ir	T2 Nm	FS'		
----------------------------	----	----------	-----	--	--

0.75 kW

 $n_1 = 2820 \text{ min}^{-1}$   
 $n_1 = 2820 \text{ min}^{-1}$   
 $n_1 = 1390 \text{ min}^{-1}$   
 $n_1 = 910 \text{ min}^{-1}$   
 $n_1 = 920 \text{ min}^{-1}$ 
71C 2  
80A 2  
80B 4  
80C 6  
90S 6

403	7	15	3.3	UMI 50	80A 2
400	7	15	3.3	UMI 50	71C 2
282	10	21	2.6	UMI 50	80A 2
280	10	21	2.6	UMI 50	71C 2
199	7	31	6.7	UMI 75	80B 4
199	7	30	3.8	UMI 63	80B 4
199	7	30	2.2	UMI 50	80B 4
139	10	43	5.1	UMI 75	80B 4
139	10	43	2.9	UMI 63	80B 4
139	10	42	1.7	UMI 50	80B 4
131	7	46	5.1	UMI 75	90S 6
131	7	46	3.0	UMI 63	90S 6
101	28	55	3.4	UMI 75	80A 2
101	28	53	2.0	UMI 63	80A 2
101	28	53	1.2	UMI 50	80A 2
100	28	54	2.0	UMI 63	71C 2
100	28	53	1.2	UMI 50	71C 2
93	15	63	3.7	UMI 75	80B 4
93	15	62	2.1	UMI 63	80B 4
93	15	62	1.2	UMI 50	80B 4
70	20	82	4.6	UMI 90	80B 4
70	20	81	2.7	UMI 75	80B 4
70	20	79	1.7	UMI 63	80B 4
70	20	78	0.9	UMI 50	80B 4
50	28	107	3.9	UMI 90	80B 4
50	28	103	2.4	UMI 75	80B 4
50	28	102	1.3	UMI 63	80B 4
35	40	146	2.8	UMI 90	80B 4
35	40	139	1.6	UMI 75	80B 4
35	40	138	1.0	UMI 63	80B 4
28	49	169	2.2	UMI 90	80B 4
28	49	169	1.3	UMI 75	80B 4
25	56	196	1.8	UMI 90	80B 4
25	56	188	1.1	UMI 75	80B 4
23	40	211	2.2	UMI 90	80C 6
23	40	211	1.2	UMI 75	80C 6
20	70	227	1.4	UMI 90	80B 4
20	70	220	0.9	UMI 75	80B 4
19	49	247	1.7	UMI 90	80C 6
19	49	243	1.0	UMI 75	80C 6
17	80	247	1.2	UMI 90	80B 4
17	80	243	0.8	UMI 75	80B 4
16	56	279	1.9	UMI 110	90S 6
16	56	278	1.4	UMI 90	80C 6
16	56	273	0.8	UMI 75	80C 6
14	100	283	1.0	UMI 90	80B 4
13	70	327	1.7	UMI 110	90S 6
13	70	325	1.1	UMI 90	80C 6
11	80	361	1.5	UMI 110	90S 6
11	80	353	1.0	UMI 90	80C 6
9	100	409	0.7	UMI 90	80C 6

1.7 Prestazioni motoriduttori

$n_2$ min <sup>-1</sup>	ir	T2 Nm	FS'		
----------------------------	----	----------	-----	--	--

<b>0.88 kW</b>		$n_1 = 1350 \text{ min}^{-1}$	80C 4
----------------	--	-------------------------------	-------

193	7	37	5.5	<b>UMI 75</b>	80C 4
193	7	37	3.1	<b>UMI 63</b>	80C 4
193	7	37	1.9	<b>UMI 50</b>	80C 4
135	10	52	4.2	<b>UMI 75</b>	80C 4
135	10	52	2.4	<b>UMI 63</b>	80C 4
135	10	51	1.4	<b>UMI 50</b>	80C 4
90	15	75	3.0	<b>UMI 75</b>	80C 4
90	15	75	1.8	<b>UMI 63</b>	80C 4
90	15	75	1.0	<b>UMI 50</b>	80C 4
68	20	100	3.8	<b>UMI 90</b>	80C 4
68	20	98	2.2	<b>UMI 75</b>	80C 4
68	20	96	1.4	<b>UMI 63</b>	80C 4
48	28	129	3.2	<b>UMI 90</b>	80C 4
48	28	125	2.0	<b>UMI 75</b>	80C 4
48	28	124	1.1	<b>UMI 63</b>	80C 4
34	40	177	2.3	<b>UMI 90</b>	80C 4
34	40	168	1.3	<b>UMI 75</b>	80C 4
34	40	167	0.9	<b>UMI 63</b>	80C 4
28	49	204	1.1	<b>UMI 75</b>	80C 4
28	49	204	1.8	<b>UMI 90</b>	80C 4
24	56	227	0.9	<b>UMI 75</b>	80C 4
24	56	237	1.5	<b>UMI 90</b>	80C 4
19	70	266	0.7	<b>UMI 75</b>	80C 4
19	70	275	1.1	<b>UMI 90</b>	80C 4
17	80	299	1.0	<b>UMI 90</b>	80C 4
14	100	342	0.8	<b>UMI 90</b>	80C 4

<b>1.1 kW</b>		$n_1 = 2830 \text{ min}^{-1}$	80B 2
		$n_1 = 1390 \text{ min}^{-1}$	80D 4
		$n_1 = 1400 \text{ min}^{-1}$	90S 4
		$n_1 = 920 \text{ min}^{-1}$	90L 6

404	7	22	6.4	<b>UMI 75</b>	80B 2
404	7	22	3.8	<b>UMI 63</b>	80B 2
404	7	22	2.3	<b>UMI 50</b>	80B 2
283	10	32	5.0	<b>UMI 75</b>	80B 2
283	10	31	3.0	<b>UMI 63</b>	80B 2
283	10	31	1.8	<b>UMI 50</b>	80B 2
200	7	45	4.6	<b>UMI 75</b>	90S 4
200	7	44	2.6	<b>UMI 63</b>	90S 4
199	7	45	4.6	<b>UMI 75</b>	80D 4
199	7	44	2.6	<b>UMI 63</b>	80D 4
189	15	46	3.7	<b>UMI 75</b>	80B 2
189	15	46	2.1	<b>UMI 63</b>	80B 2
189	15	46	1.3	<b>UMI 50</b>	80B 2
142	20	60	2.6	<b>UMI 75</b>	80B 2
142	20	59	1.0	<b>UMI 50*</b>	80B 2
140	10	63	3.5	<b>UMI 75</b>	80D 4
140	10	62	2.0	<b>UMI 63</b>	90S 4
139	10	64	5.4	<b>UMI 90</b>	80D 4
139	10	63	3.5	<b>UMI 75</b>	80D 4

N.B.  
Tutte le potenze indicate si riferiscono alla potenza meccanica dei riduttori.  
Per i riduttori contrassegnati con (\*) è opportuno effettuare la verifica della potenza limite termico secondo le indicazioni riportate nel par. 1.7-A

1.7 Gearmotors performances

$n_2$ min <sup>-1</sup>	ir	T2 Nm	FS'		
----------------------------	----	----------	-----	--	--

<b>1.1 kW</b>		$n_1 = 2830 \text{ min}^{-1}$	80B 2
		$n_1 = 1390 \text{ min}^{-1}$	80D 4
		$n_1 = 1400 \text{ min}^{-1}$	90S 4
		$n_1 = 920 \text{ min}^{-1}$	90L 6

139	10	63	2.0	<b>UMI 63</b>	80D 4
139	10	62	1.2	<b>UMI 50</b>	80D 4
131	7	68	5.6	<b>UMI 90</b>	90L 6
131	7	67	3.5	<b>UMI 75</b>	90L 6
131	7	67	2.0	<b>UMI 63</b>	90L 6
93	15	93	4.0	<b>UMI 90</b>	80D 4
93	15	91	2.5	<b>UMI 75</b>	80D 4
93	15	90	1.5	<b>UMI 63</b>	90S 4
93	15	91	1.4	<b>UMI 63</b>	80D 4
93	15	91	0.8	<b>UMI 50</b>	80D 4
70	20	121	3.2	<b>UMI 90</b>	80D 4
70	20	118	1.9	<b>UMI 75</b>	80D 4
70	20	116	1.2	<b>UMI 63</b>	90S 4
70	20	116	1.2	<b>UMI 63</b>	80D 4
61	15	137	3.2	<b>UMI 90</b>	90L 6
61	15	135	1.9	<b>UMI 75</b>	90L 6
61	15	134	1.1	<b>UMI 63</b>	90L 6
50	28	157	2.6	<b>UMI 90</b>	80D 4
50	28	150	1.6	<b>UMI 75</b>	80D 4
50	28	149	0.9	<b>UMI 63</b>	90S 4
50	28	150	0.9	<b>UMI 63</b>	80D 4
46	20	178	2.5	<b>UMI 90</b>	90L 6
46	20	172	1.3	<b>UMI 75</b>	90L 6
46	20	171	0.9	<b>UMI 63</b>	90L 6
35	40	216	3.0	<b>UMI 110</b>	90S 4
35	40	213	1.9	<b>UMI 90</b>	90S 4
29	49	254	2.3	<b>UMI 110</b>	90S 4
29	49	246	1.1	<b>UMI 90</b>	90S 4
29	49	234	1.0	<b>UMI 75</b>	90S 4
25	56	290	1.6	<b>UMI 110</b>	90S 4
25	56	286	1.2	<b>UMI 90</b>	90S 4
25	56	288	1.2	<b>UMI 90</b>	80D 4
23	40	306	0.8	<b>UMI 75</b>	90L 6
23	40	306	1.5	<b>UMI 90</b>	90L 6
20	70	336	1.4	<b>UMI 110</b>	90S 4
20	70	331	0.9	<b>UMI 90</b>	90S 4
20	70	333	0.9	<b>UMI 90</b>	80D 4
19	49	358	1.2	<b>UMI 90</b>	90L 6
18	80	360	0.8	<b>UMI 90</b>	90S 4
17	80	372	1.3	<b>UMI 110</b>	90S 4
17	80	363	0.8	<b>UMI 90</b>	80D 4
16	56	403	1.0	<b>UMI 90</b>	90L 6
14	100	428	1.0	<b>UMI 110</b>	90S 4
12	80	530	1.1	<b>UMI 110</b>	90L 6
9	100	605	0.8	<b>UMI 110</b>	90L 6

NOTE.  
The indicated power is based on the mechanical capacities of the gearboxes.  
For the gearboxes marked with (\*) it is also necessary to obey the thermal capacity like shown on chapter 1.7-A.

1.7 Leistungen der Getriebemotoren

$n_2$ min <sup>-1</sup>	ir	T2 Nm	FS'		
----------------------------	----	----------	-----	--	--

<b>1.5 kW</b>		$n_1 = 2830 \text{ min}^{-1}$	80C 2
		$n_1 = 2830 \text{ min}^{-1}$	90S 2
		$n_1 = 1400 \text{ min}^{-1}$	90L 4
		$n_1 = 925 \text{ min}^{-1}$	90LB 6
		$n_1 = 940 \text{ min}^{-1}$	100A 6

404	7	30	7.5	<b>UMI 90</b>	90S 2
404	7	31	4.7	<b>UMI 75</b>	90S 2
404	7	31	4.7	<b>UMI 75</b>	80C 2
404	7	30	2.8	<b>UMI 63</b>	90S 2
404	7	30	2.8	<b>UMI 63</b>	80C 2
283	10	43	5.9	<b>UMI 90</b>	90S 2
283	10	43	3.7	<b>UMI 75</b>	90S 2
283	10	43	3.7	<b>UMI 75</b>	80C 2
283	10	43	2.2	<b>UMI 63</b>	90S 2
283	10	43	2.2	<b>UMI 63</b>	80C 2
200	7	62	5.2	<b>UMI 90</b>	90L 4
200	7	61	3.4	<b>UMI 75</b>	90L 4
200	7	60	1.9	<b>UMI 63</b>	90L 4
189	15	63	4.4	<b>UMI 90</b>	80C 2
189	15	62	2.7	<b>UMI 75</b>	90S 2
189	15	62	2.7	<b>UMI 75</b>	80C 2
189	15	62	1.6	<b>UMI 63</b>	90S 2
189	15	62	1.6	<b>UMI 63</b>	80C 2
140	10	87	4.0	<b>UMI 90</b>	90L 4
140	10	86	2.6	<b>UMI 75</b>	90L 4
140	10	85	1.5	<b>UMI 63</b>	90L 4
93	15	126	2.9	<b>UMI 90</b>	90L 4
93	15	124	1.9	<b>UMI 75</b>	90L 4
93	15	123	1.1	<b>UMI 63</b>	90L 4
70	20	164	2.3	<b>UMI 90</b>	90L 4
70	20	160	1.4	<b>UMI 75</b>	90L 4
70	20	158	0.9	<b>UMI 63</b>	90L 4
62	15	183	3.5	<b>UMI 110</b>	90LB 6
62	15	186	2.3	<b>UMI 90</b>	90LB 6
62	15	184	1.4	<b>UMI 75</b>	90LB 6
58	49	176	1.6	<b>UMI 90</b>	80C 2
58	49	176	1.6	<b>UMI 90</b>	90S 2
58	49	176	0.9	<b>UMI 75*</b>	80C 2
58	49	176	0.9	<b>UMI 75*</b>	90S 2
51	56	201	1.4	<b>UMI 90</b>	80C 2
51	56	201	1.4	<b>UMI 90</b>	90S 2
50	28	212	2.0	<b>UMI 90</b>	90L 4
50	28	212	1.2	<b>UMI 75</b>	90L 4
46	20	241	3.0	<b>UMI 110</b>	90LB 6
46	20	242	1.8	<b>UMI 90</b>	90LB 6
46	20	238	1.0	<b>UMI 75</b>	90LB 6
41	70	237	1.0	<b>UMI 90</b>	80C 2
41	70	237	1.0	<b>UMI 90</b>	90S 2
35	40	295	2.2	<b>UMI 110</b>	90L 4
35	40	291	1.4	<b>UMI 90</b>	90L 4
35	40	287	0.8	<b>UMI 75*</b>	90L 4
29	49	346	1.7	<b>UMI 110</b>	90L 4
29	49	336	1.1	<b>UMI 90</b>	90L 4
25	56	395	1.2	<b>UMI 110</b>	90L 4

HINWEIS.  
Die Leistungsangaben beziehen sich auf die mechanische Belasbarkeit der Getriebe.  
Bei den mit (\*) gekennzeichneten Getrieben ist außerdem die thermische Leistungsgrenze zu beachten (s. Kap. 1.7-A).



## 1.7 Prestazioni motoriduttori

$n_2$ min <sup>-1</sup>	ir	T2 Nm	FS'		
----------------------------	----	----------	-----	--	--

## 1.5 kW

$n_1 = 2830 \text{ min}^{-1}$	80C 2
$n_1 = 2830 \text{ min}^{-1}$	90S 2
$n_1 = 1400 \text{ min}^{-1}$	90L 4
$n_1 = 925 \text{ min}^{-1}$	90LB 6
$n_1 = 940 \text{ min}^{-1}$	100A 6

25	56	390	0,9	UMI 90	90L 4
24	40	408	1,1	UMI 90	100A 6
23	40	415	1,1	UMI 90	90LB 6
20	70	458	1,1	UMI 110	90L 4
19	49	478	0,9	UMI 90	100A 6
19	49	486	0,9	UMI 90	90LB 6
18	80	508	1,0	UMI 110	90L 4
17	56	546	1,0	UMI 110	100A 6
17	56	555	1,0	UMI 110	90LB 6
13	70	640	0,9	UMI 110	100A 6
13	70	650	0,8	UMI 110	90LB 6

## 1.8 kW

$n_1 = 2770 \text{ min}^{-1}$	80D 2
$n_1 = 1400 \text{ min}^{-1}$	90LB 4
$n_1 = 940 \text{ min}^{-1}$	100B 6

396	7	37	6,2	UMI 90	80D 2
396	7	37	3,8	UMI 75	80D 2
396	7	37	2,2	UMI 63	80D 2
396	7	37	1,4	UMI 50*	80D 2
277	10	53	4,8	UMI 90	80D 2
277	10	52	3,0	UMI 75	80D 2
277	10	52	1,8	UMI 63	80D 2
277	10	52	1,1	UMI 50*	80D 2
200	7	74	4,3	UMI 90	90LB 4
200	7	73	2,8	UMI 75	90LB 4
200	7	72	1,6	UMI 63	90LB 4
185	15	77	3,6	UMI 90	80D 2
185	15	76	2,2	UMI 75	80D 2
185	15	76	1,3	UMI 63*	80D 2
140	10	104	3,3	UMI 90	90LB 4
140	10	103	2,1	UMI 75	90LB 4
140	10	102	1,2	UMI 63	90LB 4
93	15	151	2,5	UMI 90	90LB 4
93	15	148	1,5	UMI 75	90LB 4
93	15	147	0,9	UMI 63*	90LB 4
70	20	196	1,9	UMI 90	90LB 4
70	20	194	1,1	UMI 75	90LB 4
63	15	219	2,9	UMI 110	100B 6
63	15	219	2	UMI 90	100B 6
57	49	216	1,3	UMI 90	80D 2
57	49	216	0,8	UMI 75*	80D 2
50	28	254	1,6	UMI 90	90LB 4
50	28	254	1,0	UMI 75*	90LB 4
49	56	247	1,1	UMI 90*	80D 2
47	20	289	2,5	UMI 110	100B 6
47	20	289	1,6	UMI 90	100B 6
40	70	291	0,8	UMI 90*	80D 2
35	40	354	1,8	UMI 110	90LB 4
35	40	349	1,2	UMI 90	90LB 4
29	49	415	1,4	UMI 110	90LB 4
29	49	403	0,9	UMI 90*	90LB 4
25	56	474	1,0	UMI 110	90LB 4
20	70	550	0,9	UMI 110	90LB 4
18	80	609	0,8	UMI 110	90LB 4

## 1.7 Gearmotors performances

$n_2$ min <sup>-1</sup>	ir	T2 Nm	FS'		
----------------------------	----	----------	-----	--	--

## 2.2 kW

$n_1 = 2840 \text{ min}^{-1}$	90L 2
$n_1 = 1410 \text{ min}^{-1}$	100A 4
$n_1 = 950 \text{ min}^{-1}$	112A 6

406	7	45	5,2	UMI 90	90L 2
406	7	45	3,2	UMI 75	90L 2
406	7	45	1,9	UMI 63*	90L 2
284	10	63	4,1	UMI 90	90L 2
284	10	63	2,5	UMI 75	90L 2
284	10	62	1,5	UMI 63*	90L 2
189	15	92	3,0	UMI 90	90L 2
189	15	91	1,8	UMI 75	90L 2
189	15	91	1,1	UMI 63*	90L 2
141	10	127	2,7	UMI 90	100A 4
141	10	125	1,8	UMI 75	100A 4
101	28	159	1,2	UMI 75*	90L 2
396	7	37	6,2	UMI 90	80D 2
396	7	37	3,8	UMI 75	80D 2
277	10	53	4,8	UMI 90	80D 2
277	10	53	3,0	UMI 75	80D 2
200	7	74	4,3	UMI 90	90LB 4
200	7	73	2,8	UMI 75	90LB 4
141	10	127	2,7	UMI 90	100A 4
101	28	157	2,0	UMI 90	90L 2
101	28	159	1,2	UMI 75*	90L 2
94	15	183	2,9	UMI 110	100A 4
94	15	183	2,0	UMI 90	100A 4
94	15	181	1,3	UMI 75	100A 4
71	20	241	2,6	UMI 90	100A 4
71	20	238	1,6	UMI 90	100A 4
71	20	235	0,9	UMI 75*	100A 4
63	15	268	1,6	UMI 90	100BL 6
63	15	265	1,0	UMI 75*	100BL 6
58	49	261	1,7	UMI 110	90L 2
50	28	313	1,8	UMI 110	100A 4
50	28	309	1,3	UMI 90	100A 4
50	28	309	0,8	UMI 75*	100A 4
35	40	429	1,5	UMI 110	100A 4
35	40	423	1,0	UMI 90	100A 4
35	40	417	0,6	UMI 75	100A 4
29	49	504	1,2	UMI 110	100A 4
29	49	489	0,8	UMI 90	100A 4
25	56	576	0,8	UMI 110	100A 4

## 1.7 Leistungen der Getriebemotoren

$n_2$ min <sup>-1</sup>	ir	T2 Nm	FS'		
----------------------------	----	----------	-----	--	--

## 3 kW

$n_1 = 2840 \text{ min}^{-1}$	90LB 2
$n_1 = 2860 \text{ min}^{-1}$	100A 2
$n_1 = 1420 \text{ min}^{-1}$	100B 4
$n_1 = 940 \text{ min}^{-1}$	112B 6
$n_1 = 950 \text{ min}^{-1}$	132S 6

409	7	60	3,8	UMI 90	100A 2
406	7	61	2,3	UMI 75*	90LB 2
406	7	61	1,4	UMI 63*	90LB 2
284	10	86	3,0	UMI 90	90LB 2
284	10	86	1,8	UMI 75*	90LB 2
284	10	85	1,1	UMI 63*	90LB 2
203	7	121	2,6	UMI 90	100B 4
203	7	120	1,7	UMI 75*	100B 4
191	15	125	3,2	UMI 110	100A 2
189	15	126	2,2	UMI 90	90LB 2
189	15	124	1,3	UMI 75*	90LB 2
189	15	124	0,8	UMI 63*	90LB 2
142	10	171	3,1	UMI 110	100B 4
142	10	171	2,0	UMI 90	100B 4
142	10	169	1,3	UMI 75*	100B 4
134	7	181	2,1	UMI 90	112B 6
134	7	179	1,3	UMI 75*	112B 6
102	28	213	1,5	UMI 90*	100A 2
102	28	216	0,9	UMI 75*	100A 2
101	28	215	1,5	UMI 90*	90LB 2
101	28	217	0,9	UMI 75*	90LB 2
95	15	248	2,2	UMI 110	100B 4
95	15	248	1,5	UMI 90	100B 4
95	15	245	0,9	UMI 75*	100B 4
94	10	256	1,6	UMI 90	112B 6
94	10	253	1,0	UMI 75*	112B 6
72	40	293	1,1	UMI 90*	100A 2
71	20	327	1,9	UMI 110	100B 4
71	40	295	1,1	UMI 90*	90LB 2
71	20	323	1,2	UMI 90	100B 4
63	15	632	1,7	UMI 110	132S 6
63	15	366	1,2	UMI 90*	112B 6
58	49	349	0,8	UMI 90*	100A 2
58	49	351	0,8	UMI 90*	90LB 2
51	28	424	1,3	UMI 110	100B 4
47	20	482	1,5	UMI 110	112B 6
36	40	581	1,1	UMI 110	100B 4
29	49	682	0,9	UMI 110	100B 4



### 1.7 Prestazioni motoriduttori

$n_2$ min <sup>-1</sup>	ir	T2 Nm	FS'		
----------------------------	----	----------	-----	--	--

<b>4 kW</b>	$n_1=2860 \text{ min}^{-1}$	100B 2
	$n_1=2860 \text{ min}^{-1}$	112A 2
	$n_1=1410 \text{ min}^{-1}$	100BL 4
	$n_1=1425 \text{ min}^{-1}$	112A 4
	$n_1=950 \text{ min}^{-1}$	132M 6

409	7	80	4.2	<b>UMI 110</b>	112A 2
409	7	80	4.2	<b>UMI 110</b>	100A 2
409	7	80	2,9	<b>UMI 90</b>	100B 2
409	7	80	2,9	<b>UMI 90</b>	112A 2
409	7	80	1,8	<b>UMI 75*</b>	100B 2
409	7	80	1,8	<b>UMI 75*</b>	112A 2
286	10	114	3.4	<b>UMI 110</b>	112A 2
286	10	114	3.4	<b>UMI 110</b>	100B 2
286	10	114	2.2	<b>UMI 90*</b>	100B 2
286	10	114	2.2	<b>UMI 90*</b>	112A 2
286	10	114	1.4	<b>UMI 75*</b>	100B 2
286	10	114	1.4	<b>UMI 75*</b>	112A 2
204	7	161	3.0	<b>UMI 110</b>	112A 4
204	7	161	2.0	<b>UMI 90</b>	112A 4
204	7	160	1.3	<b>UMI 75*</b>	112A 4
201	7	163	2.0	<b>UMI 90</b>	100BL 4
201	7	161	1.3	<b>UMI 75*</b>	100BL 4
191	15	166	2.4	<b>UMI 110</b>	112A 2
191	15	166	2.4	<b>UMI 110</b>	100B 2
191	15	166	1.7	<b>UMI 90*</b>	100B 2
191	15	166	1.7	<b>UMI 90*</b>	112A 2
191	15	164	1.0	<b>UMI 75*</b>	100B 2
191	15	164	1.0	<b>UMI 75*</b>	112A 2
143	10	228	2.4	<b>UMI 110</b>	112A 4
143	20	219	1.3	<b>UMI 90*</b>	100B 2
143	20	219	1.3	<b>UMI 90*</b>	112A 2
143	10	228	1.5	<b>UMI 90*</b>	112A 4
143	10	225	1.0	<b>UMI 75*</b>	112A 4
141	10	230	1.5	<b>UMI 90*</b>	100BL 4
141	10	228	1.0	<b>UMI 75*</b>	100BL 4
136	7	239	2.4	<b>UMI 110</b>	132M 6
102	28	284	1.1	<b>UMI 90*</b>	100B 2
102	28	284	1.1	<b>UMI 90*</b>	112A 2
95	15	330	1.6	<b>UMI 110</b>	112A 4
95	15	330	1.1	<b>UMI 90*</b>	112A 4
94	15	333	1.1	<b>UMI 90*</b>	100BL 4
72	40	390	0.8	<b>UMI 90*</b>	100B 2
72	40	390	0.8	<b>UMI 90*</b>	112A 2
71	20	434	1.4	<b>UMI 110</b>	112A 4
71	20	429	0.9	<b>UMI 90*</b>	112A 4
71	20	433	0.9	<b>UMI 90*</b>	100BL 4
63	15	483	1.3	<b>UMI 110</b>	132M 6
51	28	563	1.0	<b>UMI 110*</b>	112A 4
36	40	772	0.8	<b>UMI 110*</b>	112A 4

### 1.7 Gearmotors performances

$n_2$ min <sup>-1</sup>	ir	T2 Nm	FS'		
----------------------------	----	----------	-----	--	--

<b>5.5 kW</b>	$n_1=2880 \text{ min}^{-1}$	112B 2
	$n_1=2870 \text{ min}^{-1}$	132S 2
	$n_1=1440 \text{ min}^{-1}$	132S 4
	$n_1=1400 \text{ min}^{-1}$	112BL 4
	$n_1=950 \text{ min}^{-1}$	132ML 6

411	7	110	3.1	<b>UMI 110</b>	112B 2
410	7	110	3.1	<b>UMI 110</b>	132S 2
411	7	110	2,1	<b>UMI 90*</b>	112B 2
411	7	110	1,3	<b>UMI 75*</b>	112B 2
288	10	156	2.5	<b>UMI 110</b>	112B 2
287	10	156	2.5	<b>UMI 110</b>	132S 2
288	10	155	1.6	<b>UMI 90*</b>	112B 2
288	10	155	1.0	<b>UMI 75*</b>	112B 2
200	7	226	1.4	<b>UMI 90*</b>	112BL 4
200	7	223	0,9	<b>UMI 75*</b>	112BL 4
192	15	227	1.7	<b>UMI 110*</b>	112B 2
192	15	227	1,2	<b>UMI 90*</b>	112B 2
191	15	228	1.7	<b>UMI 110*</b>	132S 2
144	10	310	1.7	<b>UMI 110</b>	132S 4
144	20	299	1,0	<b>UMI 90*</b>	112B 2
140	10	319	1,1	<b>UMI 90*</b>	112BL 4
136	7	329	1.8	<b>UMI 110</b>	132ML 6
103	28	388	0,8	<b>UMI 90*</b>	112B 2
96	15	449	1.2	<b>UMI 110*</b>	132S 4
93	15	461	1.15	<b>UMI 110*</b>	112BL 4
93	15	461	0,8	<b>UMI 90*</b>	112BL 4
63	15	663	1.0	<b>UMI 110*</b>	132ML 6

<b>7.5 kW</b>	$n_1=2890 \text{ min}^{-1}$	132SL 2
	$n_1=2860 \text{ min}^{-1}$	112BL 2
	$n_1=1440 \text{ min}^{-1}$	132M 4

413	7	149	2.3	<b>UMI 110*</b>	132SL 2
409	7	151	2.3	<b>UMI 110*</b>	112BL 2
409	7	151	1,5	<b>UMI 90*</b>	112BL 2
409	7	151	0,9	<b>UMI 75*</b>	112BL 2
289	10	211	1.9	<b>UMI 110*</b>	132SL 2
286	10	213	1.8	<b>UMI 110*</b>	112BL 2
286	10	213	1,2	<b>UMI 90*</b>	112BL 2
206	7	299	1.6	<b>UMI 110*</b>	132M 4
193	15	309	1.3	<b>UMI 110*</b>	132SL 2
191	15	312	1.3	<b>UMI 110*</b>	112BL 2
191	15	312	0,9	<b>UMI 90*</b>	112BL 2
96	15	612	0.9	<b>UMI 110*</b>	132M 4

<b>9.2 kW</b>	$n_1=1450 \text{ min}^{-1}$	132ML 4
---------------	-----------------------------	---------

207	7	365	1.3	<b>UMI 110*</b>	132ML 4
145	10	515	1.0	<b>UMI 110*</b>	132ML 4

### 1.7 Leistungen der Getriebemotoren

$n_2$ min <sup>-1</sup>	ir	T2 Nm	FS'		
----------------------------	----	----------	-----	--	--

<b>11 kW</b>	$n_1=2940 \text{ min}^{-1}$	132M 2
	$n_1=1455 \text{ min}^{-1}$	160M 4
	$n_1=965 \text{ min}^{-1}$	160L 6

420	7	215	1.6	<b>UMI 110*</b>	132M 2
294	10	304	1.3	<b>UMI 110*</b>	132M 2

N.B.  
Tutte le potenze indicate si riferiscono alla potenza meccanica dei riduttori.  
Per i riduttori contrassegnati con (\*) è opportuno effettuare la verifica della potenza limite termico secondo le indicazioni riportate nel par. 1.7-A

NOTE.  
The indicated power is based on the mechanical capacities of the gearboxes.  
For the gearboxes marked with (\*) it is also necessary to obey the thermal capacity like shown on chapter 1.7-A.

HINWEIS.  
Die Leistungsangaben beziehen sich auf die mechanische Belasbarkeit der Getriebe.  
Bei den mit (\*) gekennzeichneten Getrieben ist außerdem die thermische Leistungsgrenze zu beachten (s. Kap. 1.7-A).

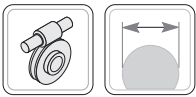

1.8 Dimensioni

1.8 Dimensions

1.8 Abmessungen



Dimensioni riduttori  
Gearboxes dimensions  
Abmessungen Getriebes

U - UI - UMI

U ( 40 - 110 )

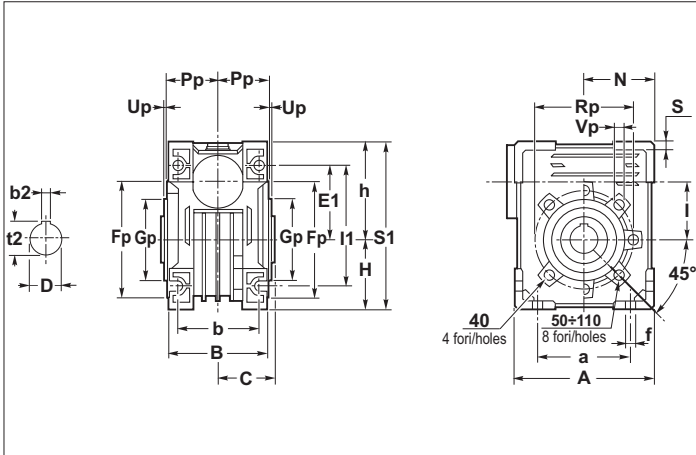

UI ( 40 - 110 )

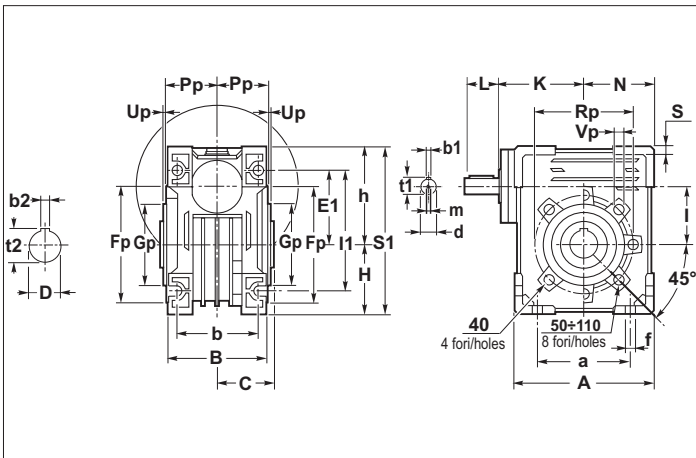

UMI ( 40 - 110 )

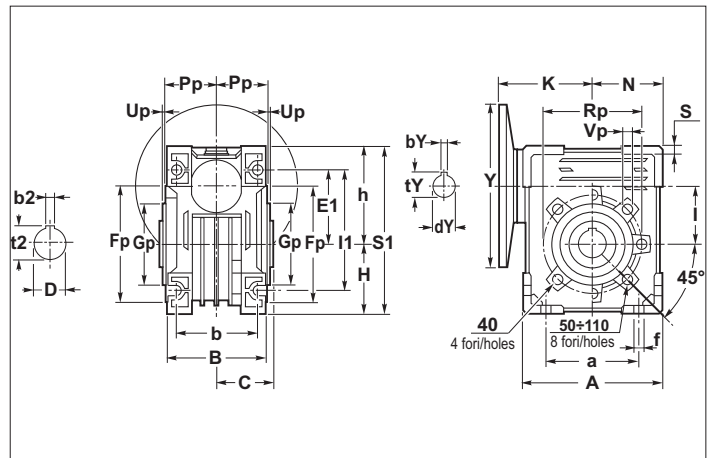

UI FA - FB ( 40 - 110 )

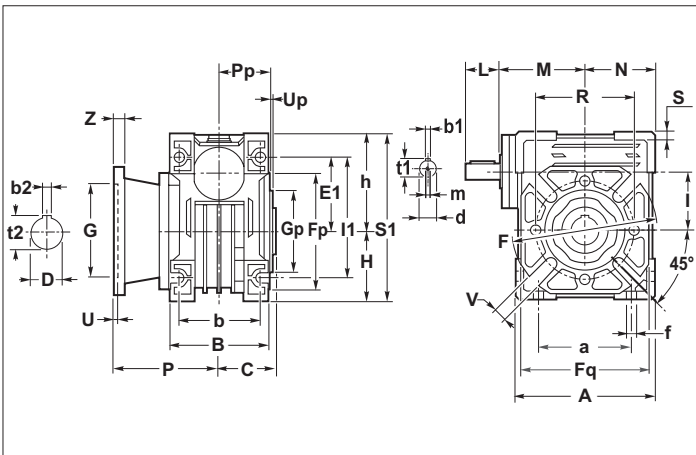

UMI FA - FB ( 40 - 110 )

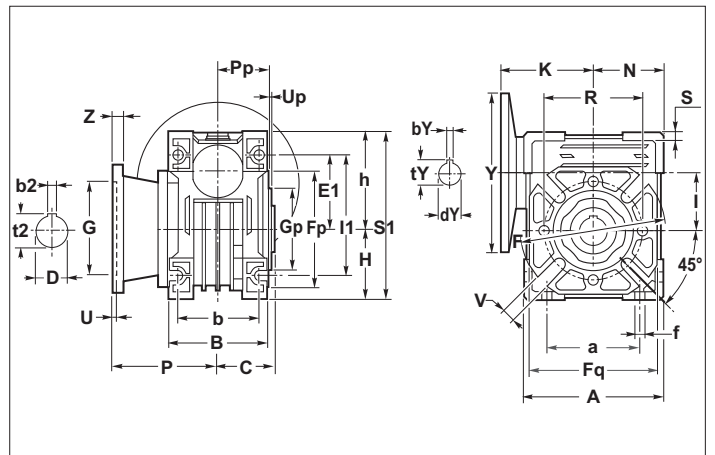

Download  
2D 3D



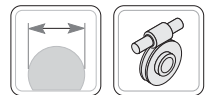

1.8 Dimensioni

1.8 Dimensions

1.8 Abmessungen

U - UI UMI	A	a	B	b	C	D <sub>H7</sub>	d <sub>j6</sub>	E1	f	h	H	I	I1	L	M	m	N	S	S1
40	100	70	71	60	39	18	11	55	6.5	71.5	50	40	90	22	64	M5	50	6	121.5
50	120	80	85	70	46	25	14	64	8.5	84	60	50	104	30	74	M6	60	7	144
63	144	100	103	85	56	25	18	80	8.5	102	72	63	130	45	96	M6	72	8	174
75	172	120	112	90	60	28 (30)	24	93	11.5	119	86	75	153	50	105	M8	86	10	205
90	206	140	130	100	70	35	24	102	13	135	103	90	172 <sub>0</sub> <sup>+3</sup>	50	125	M8	103	11	238
110	255	170	144	115	77.5	42	28	125	14	167.5	127.5	110	207	60	142	M8	127.5	14.5	295

U - UI - UMI	Fp	Gp (e8)	Pp	Rp	Up	Vp
40	87	60	36.5	75	2.5	M6
50	100	70	43.5	85	2.5	M8
63	110	80	53	95	3	M8
75	140	95	57	115	3	M8
90	160	110	67	130	3	M10
110	200	130	74	165	3.5	M10

U - UI - UMI	F	Fq	G (F8)	P	R	U	V	Z
40	FA	110	60	67	75	4	9	7
	FB			97				
50	FA	125	70	90	85	5	11	9
	FB			120				
63	FA	180	115	82	150	6	11	10
	FB			112				
75	FA	200	130	111	165	6	14	13
	FB	160	160	110	130	5	11	12
90	FA	210	152	111	175	6	14	13
	FB	250	180	122	215	6	14	16
110	FA	280	170	131	230	6	14	16

	UMI											
	40		50		63		75		90		110	
	Y	K	Y	K	Y	K	Y	K	Y	K	Y	K
B5	120	70	140	80.5	160	95	200	118	200	128	200	152
	140		160		200		120	250	130	250	152	
	160		200		—		—	—	—	—	—	300
B14	90 •	70	120	80.5	105 •	95	120	118	120	128	160	152
	105		105 •		120		140	140	128	—	—	
	—		90 •		140		160	160	130	—	—	

(•) Vedi nota in fondo a tabella 2.13

(•) See note at the bottom of table 2.13

(•) Siehe Bemerkungen Tabelle 2.13 unten

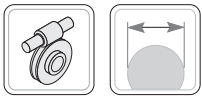

**1.9 Accessori**  
**Braccio di reazione**

**1.9 Accessories**  
**Torque arm**

**1.9 Zubehör**  
**Drehmomentstütze**

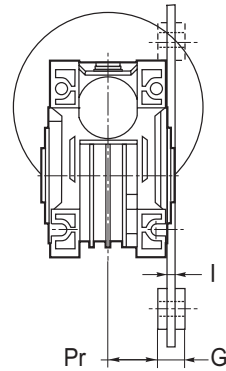
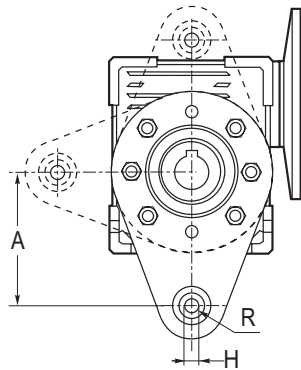

UI - UMI	40	50	63	75	90	110
A	100	100	150	200	200	250
G	15	15	20	25	25	25
H	10	10	10	20	20	20
I	4	4	6	6	6	6
Pr	31	38	48.5	47.5	57.5	64.5

**1.10 Accessori**  
**Alberi lenti**

**1.10 Accessories**  
**Output shafts**

**1.10 Zubehör**  
**Abtriebswellen**

Tutti i riduttori a vite senza fine sono forniti con albero lento cavo. A richiesta, possono essere forniti alberi lenti come indicato nei disegni dimensionali.  
Le dimensioni delle linguette sono conformi alle norme UNI 6604-69.

All worm gearboxes are supplied with hollow output shaft. Output shafts as shown in the size drawings can be supplied upon request.  
Sizes of feathers comply with standards UNI 6604-69.

Alle Schneckengetriebe werden mit hohler Abtriebswelle geliefert. Auf Anfrage können Abtriebswellen gemäß den Maßzeichnungen geliefert werden.  
Die Abmessungen der Federn entsprechen den Normen UNI 6604-69.

Albero lento  
Single output shaft  
Einseitige Abtriebswelle

Albero lento bisporgente  
Double output shaft  
Beidseitige Abtriebswelle

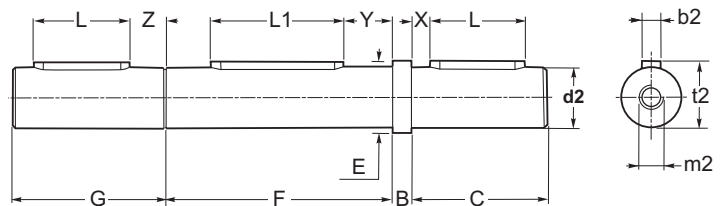
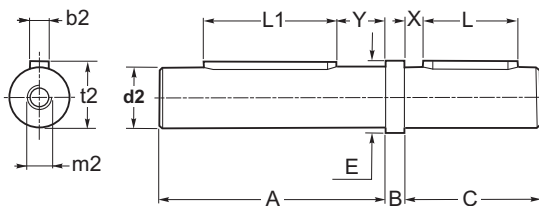

	UI - UMI					
	40	50	63	75	90	110
A	76	89	109	117	137	153
B	10	10	10	10	10	10
C	40	45	60	60	80	100
d2 g6	18	25	25	28	35	42
m2	M8	M8	M8	M8	M10	M10
E	22	28	34	34	38	50
F	78	92	112	120	140	155
G	50	55	70	70	90	110
L	25	30	40	40	50	80
L1	40	50	60	60	70	80
X	8	7.5	10	10	15	10
Y	21	24	30	30	37	37
Z	18	18	20	20	25	20

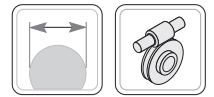

## 1.11 Linguette

## 1.11 Keys

## 1.11 Federn

## Albero Entrata - Input Shaft - Antriebswelle

UI		
d	b <sub>1</sub>	t <sub>1</sub>
9	3	10.2
11	4	12.5
14	5	16.0
16	5	18.0
18	6	20.5
19	6	21.5
24	8	27.0
25	8	28.0
28	8	31.0
30	8	33.0
32	10	35.0
35	10	38.0
38	10	41.0
42	12	45.0
45	14	48.5
48	14	51.5
50	14	53.5
55	16	59.0
65	18	69.0

UMI - PAM B5				
PAM B5	Y	dY	bY	tY
56	120	9	3	10.4
63	140	11	4	12.8
71	160	14	5	16.3
80	200	19	6	21.8
90	200	24	8	27.3
100	250	28	8	31.3
112	250	28	8	31.3
132	300	38	10	41.3
160	350	42	12	45.3
180	350	48	14	51.8
200	400	55	16	59.3

UMI - PAM B14				
PAM B14	Y	dY	bY	tY
56	80	9	3	10.4
63	90	11	4	12.8
71	105	14	5	16.3
80	120	19	6	21.8
90	140	24	8	27.3
100	160	28	8	31.3
112	160	28	8	31.3
132	200	38	10	41.3

## Albero Uscita - Output Shaft - Abtriebswelle

Albero Forato U - UI - UMI		
D	b <sub>2</sub>	t <sub>2</sub>
14	5	16.3
18	6	20.8
19	6	21.8
24	8	27.3
25	8	28.3
28	8	31.3
30	8	33.3
32	10	35.3
35	10	38.3
38	10	41.3
42	12	45.3
45	14	48.8
48	14	51.8
50	14	53.8
55	16	59.3
65	18	69.4

Albero Pieno U - UI - UMI		
d <sub>2</sub>	b <sub>2</sub>	t <sub>2</sub>
9	3	10.2
11	4	12.5
14	5	16.0
16	5	18.0
18	6	20.5
19	6	21.5
24	8	27.0
25	8	28.0
28	8	31.0
30	8	33.0
32	10	35.0
35	10	38.0
38	10	41.0
42	12	45.0
45	14	48.5
48	14	51.5
50	14	53.5
55	16	59.0
65	18	69.0



STANDARD

*line*

---