



**1.0 RIDUTTORI - MOTORIDUTTORI ORTOGONALI
HELICAL BEVELGEARBOXES AND GEARED MOTORS
KEGELRADGETRIEBE - KEGELRADGETRIEBEMOTOREN**

OM,OR,OC

				Pag. Page Seite
1.1	Caratteristiche tecniche	<i>Technical characteristics</i>	Technische Eigenschaften	C2
1.2	Designazione	<i>Designation</i>	Bezeichnungen	C2
1.3	Versioni	<i>Versions</i>	Ausführungen	C6
1.4	Lubrificazione	<i>Lubrication</i>	Schmierung	C7
1.5	Carichi radiali e assiali	<i>Axial and overhung loads</i>	Radiale und Axiale Belastungen	C9
1.6	Prestazioni riduttori	<i>Gearboxes performances</i>	Leistungen der Getriebe	C11
1.7	Prestazioni motoriduttori	<i>Gearmotors performances</i>	Leistungen der Getriebemotoren	C24
1.8	Dimensioni	<i>Dimensions</i>	Abmessungen	C38
1.9	Accessori	<i>Accessories</i>	Zubehör	C65
1.10	Linguetta	<i>Keys</i>	Paßfedern	C68

80 - 100 - 125 - 140

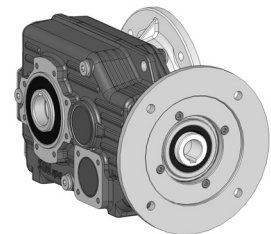
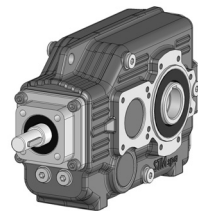

63 - 71 - 90 - 112

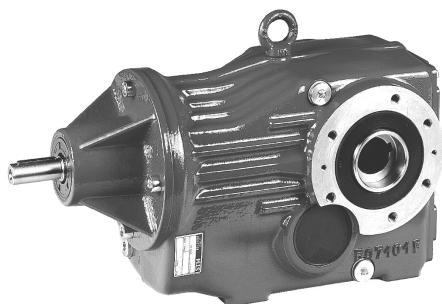
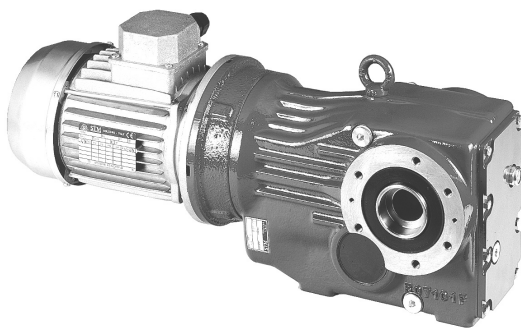

132 - 150 - 170 - 190

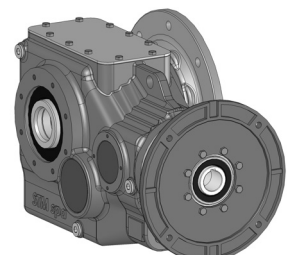
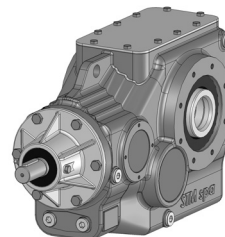



1.1 Caratteristiche tecniche

La progettazione di questi riduttori è stata impostata su una struttura monolitica particolarmente rigida che permette l'applicazione di elevati carichi.

1.1 Technical characteristics

The design of this series of gearboxes has been set up on a very rigid monolithic structure enabling the application of heavy loads.

1.1 Technische Eigenschaften

Der Entwicklung dieser Getriebeserie wurde eine monolithische Gehäusestruktur zugrunde gelegt.

1.2 Designazione

1.2 Designation

1.2 Bezeichnung



Designazione riduttori
Gearboxes designation
Bezeichnung Getriebes

OM - OR - OC

Versione Version Ausführung	Grand. Size Größe	Tipo Type Typ	* 1	* 2	* 3	* 4	* 5	* 6	* 7	ir	IEC	Tipo Type Typ	Grandezza Size Größe	Lunghezza Length Länge	Designazione Motor Designation Motors Bezeichnung Motoren										
OM	63	P**	—	—	Diametro foro opzionale Optional hollow shaft diameter	—	O	—	—	—	80 (B5) 80 (B14)	T TA H	56 315	A ML	Esempio / Example Beispiel										
	71														B	OMP 71 C 1:37.0 80 B5									
	80														C										
	90														N										
	100														D										
OR	112	F1	—	DB	Optionaler Hohlwellen durchmesser r	S	A	S	—	—	T TA H	56 315	A ML	OMP 90 1: 92.3 T 56 A 4 B5											
	125	F2	S	CD																					
	132	P		FD																					
	140			FDB																					
	150			QL																					
OC*	170			L																					
	190														OCP 112 C 1:57.1 T 56 A 4										

N.B.
* Non sono previste le versioni:
OC 80, 100, 125, 132, 140, 150, 170, 190.

** La versione P può montare le flange F1, F2, P solo nella grandezza 63

NOTE.
* We don't supply the following type:
OC 80, 100, 125, 132, 140, 150, 170, 190.

** Version P may be fitted with flanges F1, F2 and P only is size 63.

HINWEIS.
* Die Getriebetypen OC 80, 100, 125, 132, 140, 150, 170 und 190 sind nicht erhältlich.

** Auf der Version P können die Flansche F1, F2, P nur in der Baugröße 63 montiert werden.

Specifiche:

- [*1] Lato flangia uscita:
Nessuna indicazione = flangia uscita con montaggio destro.
S = flange uscita con montaggio sinistro.

Specification:

- [*1] Mounting position output side:
No indication (standard) = output flange on right side;
S = output flange on left side.

Spezifikationen:]

- [*1] Montageseite Abtriebsflansch:
Keine Angabe (Standard) = Abtriebsflansch rechts.
S = Abtriebsflansch links.

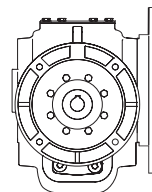
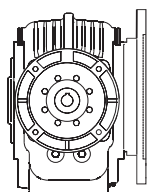
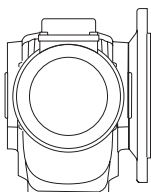

63 - 71 - 90 - 112

80 - 100 - 125 - 140

132 - 150 - 170 - 190



1.2 Designazione

- **[*2] Albero uscita:**
 Nessuna indicazione = albero forato;
B = albero bisporgente integrale
C = albero forato con calettatore
N = Sporgente Integrale
D = Sporgente Scanalato
DB = Bisporgente integrale Scanalato
CD = Albero forato Scanalato
FD = Flangia brocciata
FDB = Flangia brocciata Bisporgente
QL = Quick Locking
L = Predisposizione "Quick Locking "

1.2 Designation

- **[*2] Output shaft:**
 No indication = shaft with keyway;
B = Double integral output shaft
C = hollow shaft with shrink disc
N = Output shaft
D = Splined output shaft
DB = Double splined shaft
CD = Splined hollow shaft
FD = Broached flange
FDB = Double broached flange
QL = Quick Locking
L = Adjustment "Quick Locking "

1.2 Bezeichnung

- **[*2] Abtriebswelle:**
 Keine Angabe = Hohlwelle mit Paßfedernut
B = Doppeltem Integralwelle
C = Hohlwelle mit Schrumpfscheibe
N = Holwelle mit Wellenende
D = Abtriebswelle mit Keilende
DB = Doppelseitig verzahnte Welle
CD = Verzahnte Hohlwelle
FD = Geräumtem Flansch
FDB = Geräumter Doppelflansch
QL = Quick Locking
L = Vorbereitung "Quick Locking "

- **[*3] Diametro albero:**
 Vedi tabella .

- **[*3] Shaft diameter:**
 See table .

- **[*3] Durchmesser Abtriebswelle:**
 S. Tabelle .

Grandezza Size Größe											
	Albero forato Shaft with keyway Holwelle mit Paßfedernut		Albero forato con calettatore Hollow shaft with shrink disc Holwelle mit Schrumpfscheibe		Sporgente Integrale Output shaft Holwelle mit Wellenende	Bisporgente integrale Double output shaft Holwelle mit Doppeltem Wellenende	Sporgente Scanalato Splined output shaft Abtriebswelle mit Keilende	Bisporgente integrale Scanalato Double splined shaft Doppelseitig verzahnte Welle	Albero forato Scanalato Splined hollow shaft Verzahnte Hohlwelle	Flangia brocciata Broached flange Geräumtem Flansch	Flangia brocciata Bisporgente Double broached flange Geräumter Doppelflansch
	Standard	Optional	Standard	Optional	Standard Optional						
	-	...	C	C...	N	B	D	DB	CD	FD	FDB
	63	∅ 30	∅ 25 ∅ 28	∅ 30		∅ 30 Standard		DIN 5482 28 x 25	DIN 5482 28 x 25	-	
71	∅ 35	∅ 30 ∅ 32	∅ 35		∅ 35 Standard		DIN 5482 35 x 31	DIN 5482 35 x 31	-		
80	∅ 32	∅ 30 ∅ 35	∅ 35		∅ 32 Standard		DIN 5482 40 x 36	DIN 5482 35 x 31	DIN 5482 40 x 36		
90	∅ 40	∅ 42 ∅ 45 ∅ 48	∅ 40	-	∅ 40 Standard		DIN 5482 40 x 36	DIN 5482 40 x 36	-		
100	∅ 45	∅ 40 ∅ 50	∅ 45		∅ 45 Standard		DIN 5482 58 x 53	DIN 5482 45 x 41	DIN 5482 58 x 53		
112	∅ 50	∅ 55	∅ 50		∅ 50 Standard		DIN 5482 50 x 45	DIN 5482 50 x 45	-		
125	∅ 55	∅ 50 ∅ 60	∅ 55		∅ 55 Standard		DIN 5482 70 x 64	DIN 5482 55 x 50	DIN 5482 70 x 64		
132	∅ 60	∅ 70	∅ 60	∅ 70	∅ 60 Standard ∅ 70 Optional		FIAT 70	DIN 5482 70 x 64	FIAT 70		
140	∅ 70	∅ 60	∅ 70	-	∅ 70 Standard		FIAT 70	DIN 5482 70 x 64	FIAT 70		
150	∅ 70	∅ 80	∅ 70	∅ 80	∅ 70 Standard ∅ 80 Optional		FIAT 80	DIN 5482 80 x 74	FIAT 80		
170	∅ 90	-	∅ 90		∅ 90 Standard		FIAT 95	DIN 5482 90 x 84	FIAT 95		
190	∅ 100	-	∅ 100		∅ 100 Standard		DIN 5480 105 x 80	DIN 5482 100 x 94	DIN 5480 105 x 80		



1.2 Designazione

1.2 Designation

1.2 Bezeichnung

• **[*3] Diametro albero:**
Vedi tabella .

• **[*3] Shaft diameter:**
See table .

• **[*3] Durchmesser Abtriebswelle:**
S. Tabelle .

<p>Grandezza Size Größe</p>	<p>"Quick Locking "</p>	<p>Predisposizione "Quick Locking " Adjustement "Quick Locking " Vorbereitung "Quick Locking "</p>
	<p>71</p>	<p>Contattare nostro ufficio tecnico commerciale Please, contact our technical sales dept. Bitte setzen Sie sich mit unserer technischen Abteilung in Verbindung</p>
	<p>80</p>	
	<p>90</p>	
	<p>100</p>	
	<p>112</p>	
	<p>125</p>	
	<p>132</p>	
	<p>140</p>	
	<p>150</p>	
<p>170</p>		
<p>190</p>		

• **[*4] Posizione Albero:**
Nessuna indicazione = lato destro (standard);
S = lato sinistro, montaggio dalla parte opposta (opzionale).

• **[*4] Mounting Shaft:**
No indication (standard) = on right side;
S = on left side, on the opposite.

• **[*4] Montageposition Welle:**
Keine Angabe (Standard) = rechts;
S =links.

<p>Quick Locking</p>		<p>132-150-170-190 80-100-125-140</p>			<p>71-90-112</p>
<p>Albero forato con calettatore Hollow shaft with shrink disc Holwelle mit Schrumpfscheibe</p>					<p>—</p>
<p>Sporgente Integrale Output shaft Holwelle mit Wellenende</p>					<p>—</p>
<p>Sporgente Scanalato Splined output shaft Abtriebswelle mit Keilende</p>					<p>—</p>
<p>Albero forato Scanalato Splined hollow shaft Verzahnnte Holwelle</p>					<p>—</p>
<p>Flangia brocciata Broached flange Geräumtem Flansch</p>					<p>—</p>



1.2 Designazione

1.2 Designation

1.2 Bezeichnung

- **[*5] Senso di rotazione (valido solo se richiesto dispositivo antiretro):**
O = ORARIO (il riduttore può ruotare solo in senso orario visto dal lato destro come in figura);
A = ANTIORARIO.

- **[*5] Rotation sense (only necessary for solution with backstop device):**
O = CLOCKWISE (looking at the gearbox from the perspective shown below).
A = ANTICLOCKWISE.

- **[*5] Drehrichtung (Nur bei Ausführungen mit Rücklauf Sperre):**
O = im Uhrzeigersinn (bei Betrachtung des Getriebes aus der unten dargestellten Perspektive);
A = Gegen den Uhrzeigersinn.

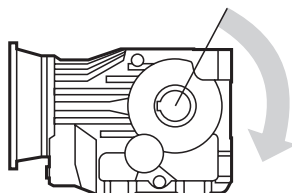

- **[*6] Posizione antiretro:**
 Nessuna indicazione = (standard);
S = montaggio dalla parte opposta (opzionale).
 N.B.
 only 80-100-125-132-140-150-170-190

- **[*6] Mounting backstop device:**
 No indication = (standard);
S = on the opposite.
 N.B.
 solo 80-100-125-132-140-150-170-190

- **[*6] Montageposition Rücklauf Sperre:**
 Keine Angabe = (Standard);
S =Gegenteile.
 N.B.
 nur 80-100-125-132-140-150-170-190

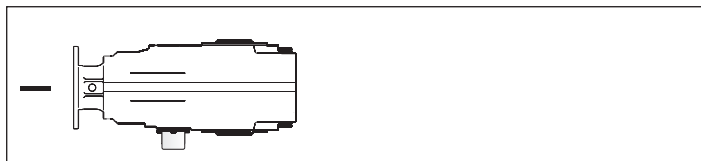

80 - 100 - 125 - 140

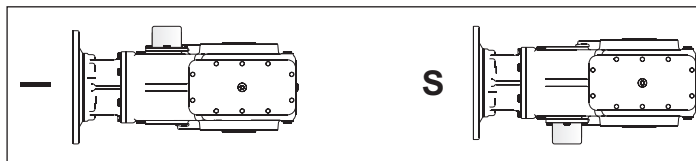

132 - 150 - 170 - 190

- **[*7] Esecuzione Grafica**
 Nessuna indicazione = Come in figura (Standard);
 NB:
 Solo per le grandezze **80-100-125-132-140-150-170-190** è possibile concordare una esecuzione speciale con nostro Ufficio Commerciale.

- **[*7] Shaft arrangement**
 No indication=Like a picture (standard);
 NB:
 Only for sizes **80-100-125-132-140-150-170-190** is available to agree a special arrangement with our sales dept.

- **[*7] Grafische Ausfuehrung**
 Keine Mitteilung= wie hier bezeichnet (Standart)
 Wichtig:
 Nur fuer die Groessen **80-100-125-132-140-150-170-190** kann man eine Sonderausfuehrung mit unserer Verkaufsabteilung besprechen.

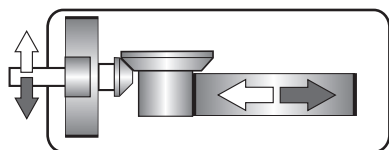

63-71-90-112

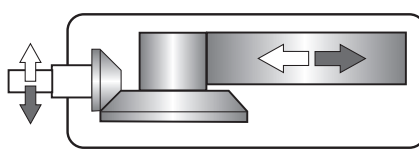

80-100-125-140

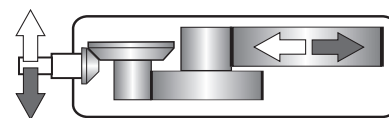

132-150-170-190

Altre specifiche:

Further specification:

Weitere Spezifikationen:

- **[M2, M3, M4, M5, M6]** Posizioni di montaggio con indicazione dei tappi di livello, carico e scarico; se non specificato si considera standard la posizione **M1** (vedi par. 1.4).
- **[T] Braccio di reazione.**
 Braccio di reazione (vedi par. 1.9).
E' possibile montare il braccio di reazione solo sulle versioni flangiate .
- **[2, 3, 4]** Posizione della morsettiera del motore se diversa da quella standard (1).

- **[M2, M3, M4, M5, M6]** Mounting position with indication of breather level and drain plugs; if not specified, standard position is **M1** (see par. 1.4).
- **[T] Torque arm**
 (see pa. 1.9).
 Only to flange casing is possible to mount a torque arm.
- **[2, 3, 4]** Position of the motor terminal box if different from the standard one (1).



- **Montageposition [M2, M3, M4, M5, M6]** mit Angabe von . Entlüftung, Schaugläsern und Ablassschraube. Wenn nicht näher spezifiziert, wird die Standard - position **M1** zugrunde gelegt (s. Abschnitt 1.4).
- **[T] Drehmomentstütze**
 (s. Abschnitt 1.9)
 Man kann die Dremomentstuetze nur bei den Versionen mit Flansch anbauen.
- **Montageposition Klemmenkasten [2, 3, 4],** wenn abweichend von Standardposition [1] (für Motorgetriebe).



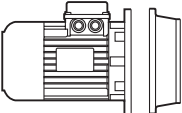

1.3 Versioni

1.3 Versions

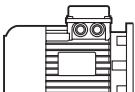
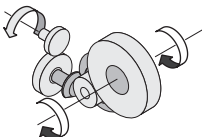
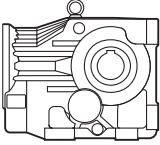
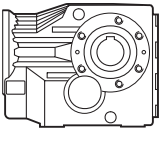
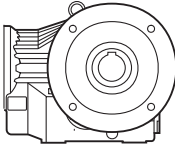
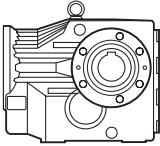
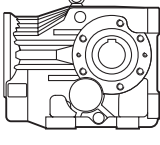
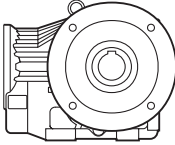
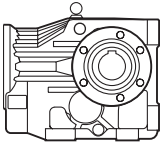
1.3 Ausführungen

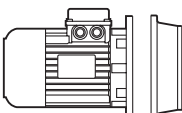
<p>OM. (IEC) → </p> <p>OM. (kW) → </p> <p>OR. → </p> <p>OC. → </p> <p> Senso di rotazione Direction of rotation Drehrichtung</p>	<p> P</p> <p> F</p> <p> F...F</p> <p> F...P</p>	<p>71 90 112</p>
<p> P</p> <p> P...F</p> <p> P...P</p>	<p>63</p>	

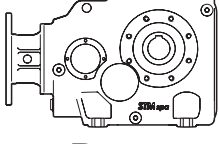
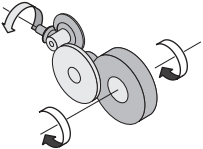
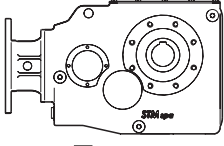
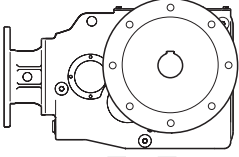
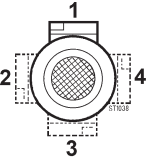
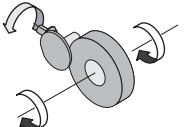
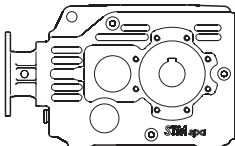
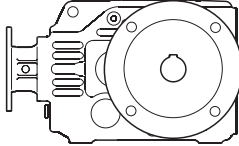
<p>OM. (IEC) → </p> <p>OM. (kW) → </p> <p>OR. → </p>	<p> P</p> <p> Senso di rotazione Direction of rotation Drehrichtung</p> <p> F</p> <p> F...F</p>	<p>132 150 170 190</p>
<p>1- STANDARD</p> <p></p> <p>Posizione morsetteria Terminal board position Lage des Klemmenkastens</p>	<p> Senso di rotazione Direction of rotation Drehrichtung</p> <p> F</p> <p> F...F</p>	<p>80 100 125 140</p>



1.4 Lubrificazione

1.4 Lubrication

1.4 Schmierung

Lubrificazione riduttori
Gearboxes lubrication
Schmierung Getriebes

OM - OR - OC

Generalità

Si consiglia l'uso di oli a base sintetica. (Vedere a tale proposito le indicazioni riportate nel capitolo A, paragrafo 1.6). Nella Tab. sono riportati i quantitativi di olio necessari per il corretto funzionamento dei riduttori.

Prescrizioni in fase d'ordine e stato di fornitura

I riduttori della grandezza 63 è forniti completi di olio sintetico di viscosità ISO 320.

Per questi riduttori **non è necessario** specificare la posizione di montaggio.

I riduttori della grandezza 71 è forniti completi di olio sintetico di viscosità ISO 320.

Per questi riduttori **è necessario** specificare la posizione di montaggio.

I riduttori nelle grandezze 80, 90, 100, 112, 125, 132, 140, 150, 170, 190 sono forniti predisposti per lubrificazione ad olio ma privi di lubrificante il quale potrà essere fornito a richiesta.

Per questi riduttori **è necessario** specificare la posizione di montaggio.

General information

The use of synthetic oil is recommended (see details in Chapter A, paragraph 1.6).

Tab. shows the quantities of oil required for correct parallel-shaft mounted gearbox performance.

Ordering phase requirements and state of supply

Size 63 gearbox is supplied with ISO 320 viscosity synthetic oil.

It is not necessary to specify mounting position of this gearbox.

Size 71 gearbox is supplied with ISO 320 viscosity synthetic oil.

It is necessary to specify the mounting position with these gearboxes.

Size 80, 90, 100, 112, 125, 132, 140, 150, 170 and 190 are supplied pre-arranged for oil lubrication but without lubricant that can be requested separately.

It is necessary to specify the mounting position with these gearboxes.

Allgemeines

Der Einsatz von synthetischem Öl wird empfohlen. (Siehe diesbezüglich die Hinweise im Kapitel A, Abschnitt 1.6).

In der Tab. werden die erforderlichen Ölfüllmengen für einen störungsfreien Betrieb der Getriebe aufgeführt.

Vorgaben für die Bestellung und den Lieferzustand

Die Getriebe in der Baugröße 63 wird komplett mit Synthetiköl mit einer Viskosität ISO 320 geliefert.

Für dieses Getriebe **muss** die Einbaulage **nicht** angegeben werden.

Die Getriebe in der Baugröße 71 wird komplett mit Synthetiköl mit einer Viskosität ISO 320 geliefert.

Für diese Getriebe **muss** die Einbaulage verbindlich angegeben werden.

Die Getriebe in den Baugrößen 80, 90, 100, 112, 125, 132, 140, 150, 170 und 190 sind bei der Lieferung für die Ölschmierung vorbereitet, enthalten jedoch kein Schmiermittel. Dieses kann auf Anfrage geliefert werden.

Posizioni di montaggio

Mounting positions

Montagepositionen

63 - 71 - 90 - 112

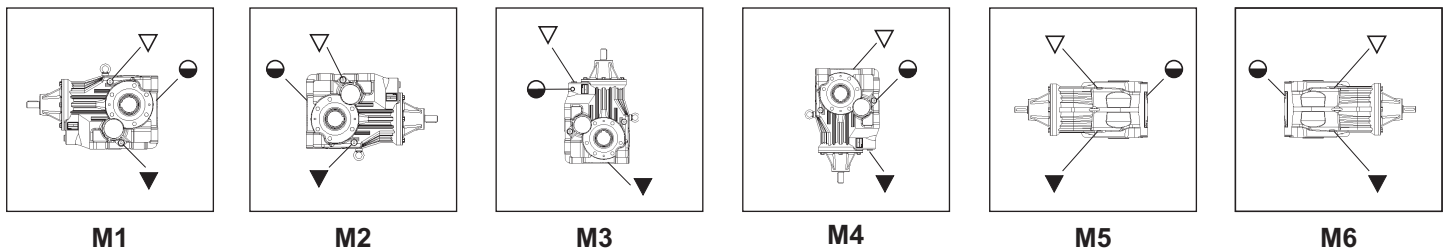

CON ANTIRETRO / WITH ANTIRUN-BACK DEVICE / MIT UMKEHRSCHUTZVORRICHTUNG									
Quantità di lubrificante / Lubricant Quantity / Schmiermittelmenge (kg)									
OM OR - OC	Posizioni di montaggio / Mounting Positions / Montagepositionen						Stato di fornitura State of supply Lieferzustand	* n°. tappi olio * No. of plugs Anzahl Betriebschraube	Pos. montaggio Mounting position Montageposition
	M1	M2	M3	M4	M5	M6			
63	1.260						Riduttori forniti completi di olio sintetico Gearboxes supplied with synthetic oil Getriebe werden mit synthetischem Öl geliefert	1	Non necessaria Not necessary Nicht erforderlich
71	1.350	1.250	1.850	1.550	1.700	1.700	Riduttori predisposti per lubrificazione ad olio Gearboxes supplied ready for oil lubrication Getriebe sind für Ölschmierung vorgesehen	1	Necessaria Necessary Erforderlich
90	2.700	2.700	3.600	2.700	2.700	2.700		7	
112	5.000	5.000	7.500	5.000	5.000	5.000		7	

SENZA ANTIRETRO / WITHOUT ANTIRUN-BACK DEVICE / OHNE UMKEHRSCHUTZVORRICHTUNG									
Quantità di lubrificante / Lubricant Quantity / Schmiermittelmenge (kg)									
OM OR - OC	Posizioni di montaggio / Mounting Positions / Montagepositionen						Stato di fornitura State of supply Lieferzustand	* n°. tappi olio * No. of plugs Anzahl Betriebschraube	Pos. montaggio Mounting position Montageposition
	M1	M2	M3	M4	M5	M6			
63	1.300						Riduttori forniti completi di olio sintetico Gearboxes supplied with synthetic oil Getriebe werden mit synthetischem Öl geliefert	1	Non necessaria Not necessary Nicht erforderlich
71	1.350	1.250	1.950	1.550	1.700	1.700	Riduttori predisposti per lubrificazione ad olio Gearboxes supplied ready for oil lubrication Getriebe sind für Ölschmierung vorgesehen	1	Necessaria Necessary Erforderlich
90	3.000	3.000	3.850	3.000	3.000	3.000		7	
112	5.500	5.500	8.200	5.500	5.500	5.500		7	



1.4 Lubrificazione

1.4 Lubrication

1.4 Schmierung

80 - 100 - 125 - 140

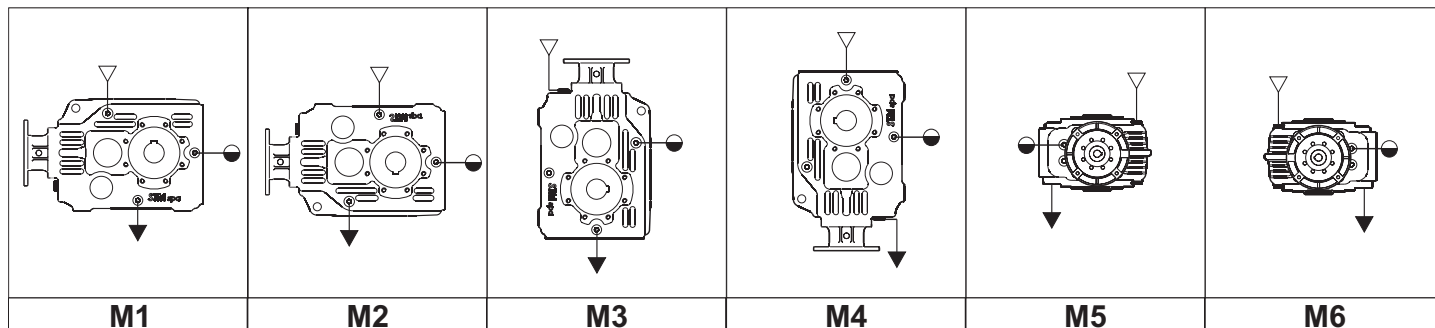

Quantità di lubrificante / Lubricant Quantity / Schmiermittelmenge (kg)									
OM OR	Posizioni di montaggio / Mounting Positions / Montagepositionen						Stato di fornitura State of supply Lieferzustand	* n°. tappi olio * No. of plugs Anzahl Betriebschraube	Pos. montaggio Mounting position Montageposition
	M1	M2	M3	M4	M5	M6			
80	1.00	1.00	1.40	1.20	1.30	1.30	Riduttori predisposti per lubrificazione ad olio Gearboxes supplied ready for oil lubrication Getriebe sind für Ölschmierung vorgesehen	8	Necessaria Necessary Erforderlich
100	2.20	2.20	2.50	2.50	2.60	2.60			
125	4.00	4.00	4.40	4.40	4.50	4.50			
140	9.10	9.10	10.2	10.5	13.3	13.3			

132 - 150 - 170 - 190

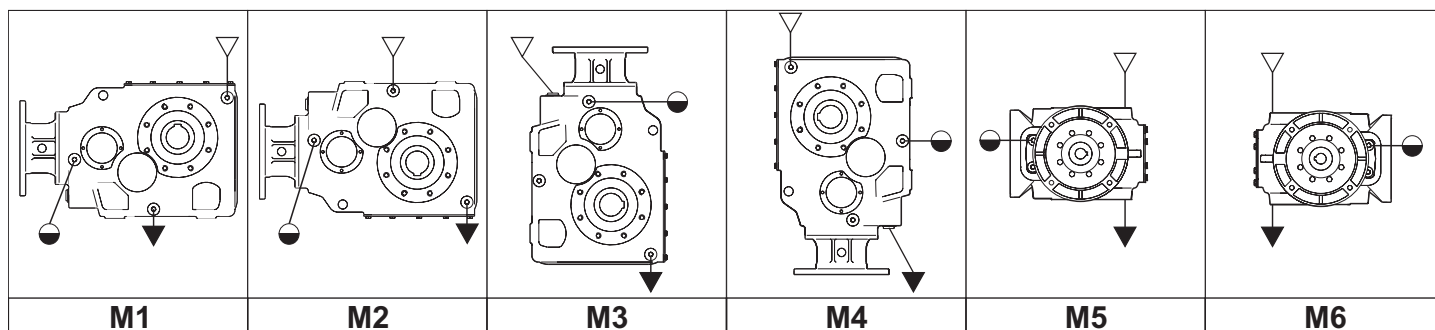

Quantità di lubrificante / Lubricant Quantity / Schmiermittelmenge (kg)									
OM OR	Posizioni di montaggio / Mounting Positions / Montagepositionen						Stato di fornitura State of supply Lieferzustand	* n°. tappi olio * No. of plugs Anzahl Betriebschraube	Pos. montaggio Mounting position Montageposition
	M1	M2	M3	M4	M5	M6			
132	8	8	14	7.5	11	11	Riduttori predisposti per lubrificazione ad olio Gearboxes supplied ready for oil lubrication Getriebe sind für Ölschmierung vorgesehen	8	Necessaria Necessary Erforderlich
150	11	11	21	12	16.5	16.5			
170	17	17	33	17	24.5	24.5			
190	23	25	43.8	25	33	33			

- ▽ Carico / Breather plug / Einfüll-u. Entlüftungsschraube
 ● Livello / Level plug / Schauglas
 ▼ Scarico / Drain plug / Ablaßschraube



Le quantità di olio sono approssimative; per una corretta lubrificazione occorre fare riferimento al livello segnato sul riduttore.

Oil quantities listed in the table are approximate; to ensure correct lubrication, please refer to the level mark on the gear unit.

Bei den Ölmenangaben handelt es sich um approximative Werte; für den Erhalt einer korrekten Schmierung muss Bezug auf den am Getriebe

ATTENZIONE

- A) Se in fase d'ordine la posizione di montaggio è omessa, il riduttore verrà fornito con i tappi predisposti per la posizione M1.
 B) Il tappo di sfianto è allegato solo nei riduttori che hanno più di un tappo olio.
 C) Eventuali forniture con predisposizioni tappi diverse da quella indicata in tabella, dovranno essere concordate.
 D) Nei riduttori dove è necessario specificare la posizione di montaggio, la posizione richiesta è indicata nella targhetta del riduttore.

WARNING

- A) It is necessary to specify the mounting position when ordering. If the mounting position is not specified in the ordering phase, the gearbox supplied will have plugs pre-arranged for position M1.
 B) A breather plug is supplied only with gearboxes that have more than one oil plug.
 C) The supply of gearboxes with different plug pre-arrangements has to be agreed with the manufacturer.
 D) The gearboxes that need a specific assembling position have the indication of it on the label of the gearbox.

ACHTUNG

- A) In der Auftragsphase muss die Einbaulage verbindlich angegeben werden. Sollte dies nicht erfolgen, wird das Getriebe mit Stopfen für die Einbaulage M1.
 B) Der Entlüftungstopfen ist lediglich bei den Getrieben vorhanden, die über mehr als einen Ölfillstopfen verfügen.
 C) Lieferungen, die eine Auslegung hinsichtlich der Stopfen aufweisen, die von den Angaben in der Tabelle abweichen, müssen vorab vereinbart werden.
 D) In den Getrieben in dem man die Montage Position angeben soll, findet man die angefragte Position auf dem Typenschild des Getriebes.



1.5 Carichi radiali e assiali

Quando la trasmissione del moto avviene tramite meccanismi che generano carichi radiali sull'estremità dell'albero, è necessario verificare che i valori risultanti non eccedano quelli indicati nelle tabelle.

Nella Tab. 3.4 sono riportati i valori dei carichi radiali ammissibili per l'albero veloce (Fr_1). Come carico assiale ammissibile contemporaneo si ha:

$$Fa_1 = 0.2 \times Fr_1$$

Tab. 3.4

1.5 Axial and overhung load

Should transmission movement determine radial loads on the angular shaft end, it is necessary to make sure that resulting values do not exceed the ones indicated in the tables.

In Table 3.4 permissible radial load for input shaft are listed (Fr_1). Contemporary permissible axial load is given by the following formula:

$$Fa_1 = 0.2 \times Fr_1$$

1.5 Radiale und axiale Belastungen

Wird das Wellenende auch durch Radialkräfte belastet, so muß sichergestellt werden, daß die resultierenden Werte die in der Tabelle angegebenen nicht überschreiten.

In Tabelle 3.4 sind die Werte der zulässigen Radialbelastungen für die Antriebswelle (Fr_1) angegeben. Die Axialbelastung beträgt dann:

$$Fa_1 = 0.2 \times Fr_1$$

63 - 71 - 80 - 90 - 100 - 112 - 125

n_1 [min ⁻¹]	Fr_1 [N]						
	OR .						
	63	71	80	90	100	112	125
2800	320	430	450	520	650	600	800
1400	400	550	550	700	800	800	1000
900	450	600	600	800	900	920	1200
500	500	850	850	1100	1000	1300	1600

132 - 140 - 150 - 170 - 170

n_1 [min ⁻¹]	Fr_1 [N]				
	OR .				
	132	140	150	170	190
2800	*	1500	*	*	*
1400		2000			
900		2500			
500		3000			

*Contattare il ns. servizio tecnico / Contact our technical dept / Wenden Sie sich an unseren technischen Service

In Tab. 3.5 sono riportati i valori dei carichi radiali ammissibili per l'albero lento (Fr_2). Come carico assiale ammissibile contemporaneo si ha:

$$Fa_2 = 0.2 \times Fr_2$$

In Table 3.5 permissible radial loads for output shaft are listed (Fr_2). Permissible axial load is given by the following formula:

$$Fa_2 = 0.2 \times Fr_2$$

In Tabelle 3.5 sind die Werte der zulässigen Radialbelastungen für die Abtriebswelle (Fr_2) angegeben. Als zulässige Axialbelastung gilt:

$$Fa_2 = 0.2 \times Fr_2$$



1.5 Carichi radiali e assiali

1.5 Axial and overhung load

1.5 Radiale und axiale Belastungen

Tab. 3.5

63 - 71 - 80 - 90 - 100 - 112 - 125							
Fr ₂ [N]							
n ₂ [min ⁻¹]	63	71	80	90	100	112	125
400	1500	2900	5000	9000	8000	11000	12500
320	1750	3000	5500	10000	9000	11500	14000
260	1950	3300	6000	10600	10000	12000	16000
200	2050	3600	6000	11400	10000	12500	16000
160	2250	3700	6000	12000	10000	13200	16000
125	2400	4050	6000	12500	10000	13300	16000
90	2750	4400	6500	13500	10000	15000	16000
60	2900	4800	7100	13500	10600	16600	17000
40	3300	5300	7500	13500	11800	17500	19000
25	4000	6500	8000	13500	12500	17500	20000
16	4500	6500	8000	13500	12500	17500	20000
10	5300	6500	8000	13500	12500	17500	20000
5	6400	6500	8000	13500	12500	17500	20000

132 - 140 - 150 - 170 - 190					
Fr ₂ [N]					
n ₂ [min ⁻¹]	132	140	150	170	190
320	13500	14000	17500	19400	25200
250	15500	16000	19200	21100	27800
200	16500	18000	20500	23300	29500
160	17500	18500	22100	24800	32000
112	19000	20000	23500	27000	35200
63	23000	28000	27500	34200	44600
36	29000	30000	34000	41000	53200
<12.5	32500	35000	43000	57000	65000

I carichi radiali indicati nelle tabelle si intendono applicati a metà della sporgenza dell'albero lento standard (vedi fig. 2.6) e sono riferiti ai riduttori operanti con fattore di servizio 1.

Valori intermedi relativi a velocità non riportate possono essere ottenuti per interpolazione considerando però che Fr₁ a 500 min⁻¹ e Fr₂ a 5 min⁻¹ rappresentano i carichi massimi consentiti. Per i carichi non agenti sulla mezzeria dell'albero lento o veloce si ha:

- a 0.3 della sporgenza: $F_{rx} = 1.25 \times F_{r1-2}$
- a 0.8 della sporgenza: $F_{rx} = 0.8 \times F_{r1-2}$

The radial loads shown in the tables are applied on the middle of standard shaft extensions (see fig. 2.6). Base of these values is a service factor 1.

Values for speeds that are not listed can be obtained through interpolation but it must be considered that Fr₁ at 500 min⁻¹ and Fr₂ at 5 min⁻¹ represent the maximum allowable loads.

For radial loads which are not applied on the middle of the shafts, the following values can be calculated:

- at 0.3 from extension: $F_{rx} = 1.25 \times F_{r1-2}$
- at 0.8 from extension: $F_{rx} = 0.8 \times F_{r1-2}$

Bei den in der Tabelle angegebenen Radialbelastungen wird eine Kräfteinwirkung auf die Mitte der Standardwelle (s. A. 2.6) angenommen; außerdem wird ein Betriebsfaktor 1 zugrunde gelegt. Zwischenwerte für nicht aufgeführte Drehzahlen können durch Interpolation ermittelt werden. Hierbei ist jedoch zu berücksichtigen, daß Fr₁ bei 500 min⁻¹ und für Fr_{2max} bei 5 min⁻¹ die maximal zulässigen Belastungen repräsentieren.

Ist die Einwirkung der Radialkraft nicht in der Mitte der Welle, so können die zulässigen Radiallasten folgendermaßen ermittelt werden:

- 0.3 vom Wellenabsatz entfernt: $F_{rx} = 1.25 \times F_{r1-2}$
- 0.8 vom Wellenabsatz entfernt: $F_{rx} = 0.8 \times F_{r1-2}$

Tab. 2.6

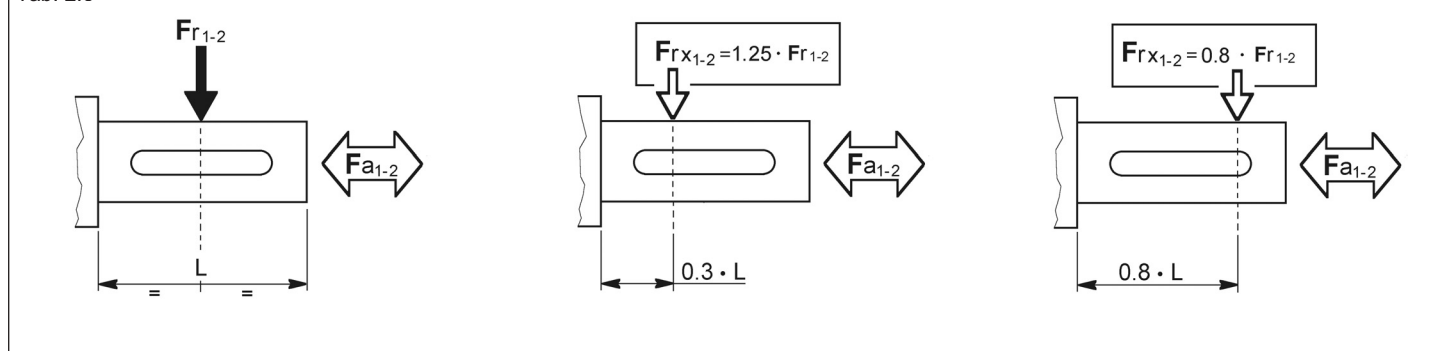



OR 63



10.5

ir	n ₁ = 2800 min ⁻¹				n ₁ = 1400 min ⁻¹				n ₁ = 900 min ⁻¹				n ₁ = 500 min ⁻¹				IEC
	n ₂	T _{2M}	P	RD	n ₂	T _{2M}	P	RD	n ₂	T _{2M}	P	RD	n ₂	T _{2M}	P	RD	
	min ⁻¹	Nm	kW	%	min ⁻¹	Nm	kW	%	min ⁻¹	Nm	kW	%	min ⁻¹	Nm	kW	%	
7.9	354	140	5.8	90	177	170	3.5	90	114	190	2.5	90	63	200	1.5	90	112 B5 112 B14 100 B5 100 B14 90 B5 90 B14 80 B5 80 B14 71 B5 63 B5
10.3	272	150	4.7	90	136	185	2.9	90	88	200	2.0	90	49	215	1.2	90	
11.5	244	155	4.4	90	122	190	2.7	90	78	205	1.9	90	44	220	1.1	90	
13.3	211	175	4.3	90	105	220	2.7	90	68	235	1.9	90	38	245	1.1	90	
14.8	189	180	4.0	90	94	220	2.4	90	61	240	1.7	90	34	250	0.99	90	
17.2	163	185	3.5	90	82	220	2.1	90	52	245	1.5	90	29	255	0.86	90	
19.5	143	190	3.2	90	72	230	1.9	90	46	245	1.3	90	26	255	0.77	90	
23.7	118	220	3.0	90	59	240	1.6	90	38	260	1.1	90	21	270	0.66	90	
27.5	102	225	2.7	90	51	240	1.4	90	33	260	1.0	90	18.2	270	0.57	90	
31.2	90	230	2.4	90	45	240	1.3	90	29	260	0.88	90	16.0	270	0.50	90	
35.8	78	230	2.1	90	39	250	1.1	90	25	260	0.76	90	14.0	270	0.44	90	
44.6	63	230	1.7	90	31	250	0.90	90	20	260	0.61	90	11.2	270	0.35	90	
52.4	53	230	1.4	90	27	250	0.79	90	17.2	260	0.52	90	9.5	270	0.30	90	
69.0	41	230	1.1	90	20	250	0.58	90	13.0	260	0.39	90	7.2	270	0.23	90	
79.5	35	230	0.94	90	17.6	250	0.51	90	11.3	260	0.34	90	6.3	270	0.20	90	
90.6	31	200	0.72	90	15.4	230	0.41	90	9.9	250	0.29	90	5.5	265	0.17	90	
103.8	27	200	0.63	90	13.5	235	0.37	90	8.7	250	0.25	90	4.8	265	0.15	90	
129.3	22	200	0.51	90	10.8	240	0.30	90	7.0	260	0.21	90	3.9	270	0.12	90	
151.9	18.4	205	0.44	90	9.2	245	0.26	90	5.9	260	0.18	90	3.3	280	0.11	90	
200.1	14.0	210	0.34	90	7.0	250	0.20	90	4.5	260	0.14	90	2.5	280	0.08	90	
243.3	11.5	230	0.31	90	5.8	250	0.17	90	3.7	270	0.12	90	2.1	290	0.07	90	
280.4	10.0	230	0.27	90	5.0	250	0.15	90	3.2	280	0.10	90	1.8	290	0.06	90	
346.4	8.1	230	0.22	90	4.0	250	0.12	90	2.6	280	0.08	90	1.4	290	0.05	90	

Pt _N [kW]	tutti i rapporti all ratios alle Untersetzungen
	2.8

N.B. Per i riduttori evidenziati dal doppio bordo nella colonna delle potenze è necessario verificare lo scambio termico del riduttore (come indicato nel par. A-1.5). Per maggiori informazioni contattare l'ufficio tecnico STM.

NOTE. Please pay attention to the frame around the input power value: for this gearboxes it's important to check the thermal capacity (comp. par. A-1.5). For details please contact our technical department).
For details please contact our technical

HINWEIS. Sind in den Tabellen Nennleistungen eingerahmt, so ist die thermische Leistungsgrenze der Getriebe zu beachten (s. Kapitel A-1.5). Für weitere Informationen wenden Sie sich bitte an unser technisches Büro.

N.B. I pesi riportati sono indicativi e possono variare in funzione della versione del riduttore.

NOTE. Listed weights are for reference only and can vary according to the gearbox version.

HINWEIS. Die angegeben Gewichtsmasse sind Richtwerte und können je nach Getriebeversion variieren.



OR 71



18.0

ir	n ₁ = 2800 min ⁻¹				n ₁ = 1400 min ⁻¹				n ₁ = 900 min ⁻¹				n ₁ = 500 min ⁻¹				IEC
	n ₂ min ⁻¹	T _{2M} Nm	P kW	RD %	n ₂ min ⁻¹	T _{2M} Nm	P kW	RD %	n ₂ min ⁻¹	T _{2M} Nm	P kW	RD %	n ₂ min ⁻¹	T _{2M} Nm	P kW	RD %	
6.9	408	220	10.4	90	204	270	6.4	90	131	294	4.5	90	73	296	2.5	90	112 B5 112 B14
8.4	333	250	9.7	90	167	300	5.8	90	107	312	3.9	90	59	313	2.1	90	
9.9	282	260	8.5	90	141	320	5.2	90	91	350	3.7	90	50	350	2.0	90	100 B5 100 B14
11.4	246	280	8.0	90	123	340	4.9	90	79	380	3.5	90	44	435	2.2	90	
13.9	201	320	7.5	90	100	400	4.7	90	65	440	3.3	90	36	490	2.1	90	90 B5 90 B14
16.5	170	330	6.5	90	85	400	4.0	90	55	440	2.8	90	30	500	1.7	90	
18.7	150	330	5.8	90	75	410	3.6	90	48	460	2.6	90	27	560	1.8	90	80 B5 80 B14
22.9	122	350	5.0	90	61	430	3.1	90	39	490	2.2	90	22	585	1.5	90	
27.1	103	375	4.5	90	52	460	2.8	90	33	525	2.0	90	18.5	597	1.3	90	71 B5
30.6	92	375	4.0	90	46	460	2.5	90	29	525	1.8	90	16.4	597	1.1	90	
37.1	76	375	3.3	90	38	460	2.0	90	24	525	1.5	90	13.5	597	0.94	90	63 B5
42.6	66	375	2.9	90	33	460	1.8	90	21	525	1.3	90	11.7	597	0.81	90	
49.3	57	375	2.5	90	28	460	1.5	90	18.2	525	1.1	90	10.1	599	0.70	90	112 B5 112 B14
53.4	52	375	2.3	90	26	460	1.4	90	16.9	525	1.0	90	9.4	602	0.66	90	
57.9	48	375	2.1	90	24	460	1.3	90	15.5	525	0.95	90	8.6	604	0.60	90	100 B5 100 B14
76.1	37	375	1.6	90	18.4	460	0.98	90	11.8	525	0.72	90	6.6	610	0.47	90	
87.4	32	375	1.4	90	16.0	460	0.86	90	10.3	525	0.63	90	5.7	612	0.41	90	90 B5 90 B14
98.6	28	375	1.2	90	14.2	460	0.76	90	9.1	525	0.56	90	5.1	614	0.36	90	
107.6	26	375	1.1	90	13.0	460	0.70	90	8.4	525	0.51	90	4.6	598	0.32	90	80 B5 80 B14
123.5	23	375	1.0	90	11.3	460	0.60	90	7.3	525	0.45	90	4.0	608	0.28	90	
143.1	19.6	375	0.86	90	9.8	460	0.52	90	6.3	525	0.38	90	3.5	618	0.25	90	71 B5
154.8	18.1	375	0.79	90	9.0	460	0.48	90	5.8	525	0.35	90	3.2	621	0.23	90	
168.0	16.7	375	0.73	90	8.3	460	0.44	90	5.4	525	0.33	90	3.0	622	0.22	90	63 B5
179.6	15.6	375	0.68	90	7.8	460	0.42	90	5.0	513	0.30	90	2.8	555	0.18	90	
193.6	14.5	375	0.63	90	7.2	460	0.39	90	4.6	516	0.28	90	2.6	558	0.17	90	112 B5 112 B14
209.4	13.4	375	0.58	90	6.7	460	0.36	90	4.3	522	0.26	90	2.4	567	0.16	90	
220.8	12.7	375	0.55	90	6.3	460	0.34	90	4.1	525	0.25	90	2.3	625	0.17	90	100 B5 100 B14
253.4	11.0	375	0.48	90	5.5	460	0.29	90	3.6	525	0.22	90	2.0	625	0.15	90	
286.0	9.8	375	0.43	90	4.9	460	0.26	90	3.1	525	0.19	90	1.7	625	0.12	90	90 B5 90 B14
298.8	9.4	375	0.41	90	4.7	460	0.25	90	3.0	525	0.18	90	1.7	590	0.12	90	
342.9	8.2	375	0.36	90	4.1	460	0.22	90	2.6	525	0.16	90	1.5	607	0.11	90	80 B5 80 B14
387.0	7.2	375	0.31	90	3.6	460	0.19	90	2.3	525	0.14	90	1.3	618	0.09	90	

Pt _N [kW]	tutti i rapporti all ratios alle Untersetzungen
	4.0

N.B. Per i riduttori evidenziati dal doppio bordo nella colonna delle potenze è necessario verificare lo scambio termico del riduttore (come indicato nel par. A-1.5). Per maggiori informazioni contattare l'ufficio tecnico STM.

NOTE. Please pay attention to the frame around the input power value: for this gearboxes it's important to check the thermal capacity (comp. par. A-1.5). For details please contact our technical department).
For details please contact our technical

HINWEIS. Sind in den Tabellen Nennleistungen eingerahmt, so ist die thermische Leistungsgrenze der Getriebe zu beachten (s. Kapitel A-1.5). Für weitere Informationen wenden Sie sich bitte an unser technisches Büro.

N.B. I pesi riportati sono indicativi e possono variare in funzione della versione del riduttore.

NOTE. Listed weights are for reference only and can vary according to the gearbox version.

HINWEIS. Die angegebenen Gewichtsmaße sind Richtwerte und können je nach Getriebeversion variieren.



OR 80

20.0

ir	$n_1 = 2800 \text{ min}^{-1}$				$n_1 = 1400 \text{ min}^{-1}$				$n_1 = 900 \text{ min}^{-1}$				$n_1 = 500 \text{ min}^{-1}$				IEC
	n_2 min ⁻¹	T_{2M} Nm	P kW	RD %	n_2 min ⁻¹	T_{2M} Nm	P kW	RD %	n_2 min ⁻¹	T_{2M} Nm	P kW	RD %	n_2 min ⁻¹	T_{2M} Nm	P kW	RD %	
5,2	544	279	16,7	95	272	310	9,3	95	175	315	6,1	95	97	315	3,4	95	112 B5 112 B14 100 B5 100 B14 90 B5 90 B14 80 B5 80 B14 71 B5
7,1	394	342	14,8	95	197	380	8,2	95	127	386	5,4	95	70	386	3,0	95	
10,0	281	450	13,9	95	140	500	7,7	95	90	508	5,1	95	50	508	2,8	95	
11,9	234	495	12,8	95	117	550	7,1	95	75	558	4,6	95	42	558	2,6	95	
14,6	191	540	11,4	95	96	600	6,3	95	61	609	4,1	95	34	609	2,3	95	
16,7	168	540	10,0	95	84	600	5,6	95	54	609	3,6	95	30	609	2,0	95	
21,2	132	540	7,9	95	66	600	4,4	95	42	609	2,8	95	24	609	1,6	95	
24,2	116	540	6,9	95	58	600	3,8	95	37	609	2,5	95	21	609	1,4	95	
31,0	90	495	4,9	95	45	550	2,7	95	29	558	1,8	95	16,1	558	1,0	95	
39,8	70	495	3,8	95	35	550	2,1	95	23	558	1,4	95	12,6	558	0,8	95	
51,0	55	495	3,0	95	27	550	1,7	95	17,6	558	1,1	95	9,8	558	0,6	95	
57,0	49	450	2,4	95	25	500	1,4	95	15,8	508	0,9	95	8,8	508	0,5	95	
73,2	38	495	2,1	95	19,1	550	1,2	95	12,3	558	0,8	95	6,8	558	0,4	95	

Pt _N [kW]	tutti i rapporti all ratios alle Untersetzungen
	9.5

N.B. Per i riduttori evidenziati dal doppio bordo nella colonna delle potenze è necessario verificare lo scambio termico del riduttore (come indicato nel par. A-1.5). Per maggiori informazioni contattare l'ufficio tecnico STM.

*NOTE. Please pay attention to the frame around the input power value: for this gearboxes it's important to check the thermal capacity (comp. par. A-1.5). For details please contact our technical department).
For details please contact our technical*

HINWEIS. Sind in den Tabellen Nennleistungen eingerahmt, so ist die thermische Leistungsgrenze der Getriebe zu beachten (s. Kapitel A-1.5). Für weitere Informationen wenden Sie sich bitte an unser technisches Büro.

N.B. I pesi riportati sono indicativi e possono variare in funzione della versione del riduttore.

NOTE. Listed weights are for reference only and can vary according to the gearbox version.

HINWEIS. Die angegebenen Gewichtsmaße sind Richtwerte und können je nach Getriebeversion variieren.



OR 90



44.0

ir	n ₁ = 2800 min ⁻¹				n ₁ = 1400 min ⁻¹				n ₁ = 900 min ⁻¹				n ₁ = 500 min ⁻¹				IEC
	n ₂ min ⁻¹	T _{2M} Nm	P kW	RD %	n ₂ min ⁻¹	T _{2M} Nm	P kW	RD %	n ₂ min ⁻¹	T _{2M} Nm	P kW	RD %	n ₂ min ⁻¹	T _{2M} Nm	P kW	RD %	
7.2	388	325	14.7	90	194	430	9.7	90	125	457	6.6	90	69	545	4.4	90	132 B5 132 B14
9.0	310	350	12.6	90	155	450	8.1	90	100	490	5.7	90	55	586	3.7	90	
10.1	276	357	11.5	90	138	500	8.0	90	89	550	5.7	90	49	600	3.4	90	
11.5	244	400	11.4	90	122	520	7.4	90	79	560	5.1	90	44	613	3.1	90	
13.0	215	406	10.2	90	108	540	6.8	90	69	570	4.6	90	38	613	2.7	90	
14.0	200	528	12.3	90	100	590	6.9	90	64	740	5.5	90	36	850	3.6	90	
15.7	178	570	11.8	90	89	720	7.5	90	57	780	5.2	90	32	950	3.5	90	
17.7	158	570	10.5	90	79	750	6.8	90	51	820	4.9	90	28	950	3.1	90	
20.1	139	610	9.9	90	70	790	6.4	90	45	870	4.6	90	25	950	2.8	90	
23.0	122	640	9.1	90	61	820	5.8	90	39	900	4.1	90	22	950	2.4	90	
25.7	109	700	8.9	90	55	900	5.8	90	35	980	4.0	90	19.5	1122	2.5	90	
28.8	97	740	8.4	90	49	910	5.2	90	31	1040	3.8	90	17.3	1122	2.3	90	
32.5	86	740	7.4	90	43	910	4.6	90	28	1040	3.4	90	15.4	1122	2.0	90	
36.9	76	740	6.5	90	38	910	4.0	90	24	1040	2.9	90	13.5	1122	1.8	90	
42.2	66	740	5.7	90	33	910	3.5	90	21	1040	2.5	90	11.9	1122	1.6	90	
45.2	62	740	5.3	90	31	910	3.3	90	19.9	1040	2.4	90	11.1	1122	1.4	90	
52.4	53	740	4.6	90	27	910	2.9	90	17.2	1040	2.1	90	9.5	1122	1.2	90	
59.5	47	740	4.0	90	24	910	2.5	90	15.1	1040	1.8	90	8.4	1122	1.1	90	
73.3	38	740	3.3	90	19.1	910	2.0	90	12.3	1040	1.5	90	6.8	1122	0.89	90	
80.7	35	740	3.0	90	17.4	910	1.8	90	11.2	1040	1.4	90	6.2	1122	0.81	90	
92.5	30	740	2.6	90	15.1	910	1.6	90	9.7	1040	1.2	90	5.4	1122	0.70	90	
94.4	30	740	2.6	90	14.8	910	1.6	90	9.5	1040	1.1	90	5.3	1122	0.69	90	
106.7	26	740	2.2	90	13.1	910	1.4	90	8.4	1040	1.0	90	4.7	1122	0.61	90	
122.3	23	740	2.0	90	11.4	910	1.2	90	7.4	1040	0.90	90	4.1	1122	0.54	90	
131.1	21	740	1.8	90	10.7	910	1.1	90	6.9	1040	0.83	90	3.8	1122	0.50	90	
151.9	18.4	740	1.6	90	9.2	910	0.97	90	5.9	1040	0.71	90	3.3	1122	0.43	90	
165.2	16.9	740	1.5	90	8.5	910	0.90	90	5.4	1040	0.65	90	3.0	1122	0.39	90	
212.6	13.2	740	1.1	90	6.6	910	0.70	90	4.2	1040	0.51	90	2.4	1122	0.31	90	
234.1	12.0	740	1.0	90	6.0	910	0.64	90	3.8	1040	0.46	90	2.1	1122	0.27	90	
268.3	10.4	740	0.90	90	5.2	910	0.55	90	3.4	1040	0.41	90	1.9	1122	0.25	90	
294.9	9.5	740	0.82	90	4.7	910	0.50	90	3.1	1040	0.38	90	1.7	1122	0.22	90	
309.6	9.0	740	0.77	90	4.5	910	0.48	90	2.9	1040	0.35	90	1.6	1122	0.21	90	
338.1	8.3	740	0.71	90	4.1	910	0.43	90	2.7	1040	0.33	90	1.5	1122	0.20	90	
390.0	7.2	740	0.62	90	3.6	910	0.38	90	2.3	1040	0.28	90	1.3	1122	0.17	90	

Pt _N [kW]	tutti i rapporti all ratios alle Untersetzungen
	6.2

N.B. Per i riduttori evidenziati dal doppio bordo nella colonna delle potenze è necessario verificare lo scambio termico del riduttore (come indicato nel par. A-1.5). Per maggiori informazioni contattare l'ufficio tecnico STM.

NOTE. Please pay attention to the frame around the input power value: for this gearboxes it's important to check the thermal capacity (comp. par. A-1.5). For details please contact our technical department).
For details please contact our technical

HINWEIS. Sind in den Tabellen Nennleistungen eingerahmt, so ist die thermische Leistungsgrenze der Getriebe zu beachten (s. Kapitel A-1.5). Für weitere Informationen wenden Sie sich bitte an unser technisches Büro.

N.B. I pesi riportati sono indicativi e possono variare in funzione della versione del riduttore.

NOTE. Listed weights are for reference only and can vary according to the gearbox version.

HINWEIS. Die angegebenen Gewichtsmaße sind Richtwerte und können je nach Getriebeversion variieren.



OR 100

32.0

ir	$n_1 = 2800 \text{ min}^{-1}$				$n_1 = 1400 \text{ min}^{-1}$				$n_1 = 900 \text{ min}^{-1}$				$n_1 = 500 \text{ min}^{-1}$				IEC
	n_2	T_{2M}	P	RD	n_2	T_{2M}	P	RD	n_2	T_{2M}	P	RD	n_2	T_{2M}	P	RD	
	min^{-1}	Nm	kW	%	min^{-1}	Nm	kW	%	min^{-1}	Nm	kW	%	min^{-1}	Nm	kW	%	
5,2	544	450	27,0	95	272	500	15,0	95	175	508	9,8	95	97	508	5,4	95	132 B5 132 B14 112 B5 100 B5 90 B5 80 B5
7,4	378	684	28,5	95	189	760	15,8	95	121	771	10,3	95	67	771	5,7	95	
10,0	281	882	27,3	95	140	980	15,2	95	90	995	9,9	95	50	995	5,5	95	
12,2	230	900	22,8	95	115	1000	12,7	95	74	1015	8,3	95	41	1015	4,6	95	
14,6	191	1035	21,8	95	96	1150	12,1	95	61	1167	7,9	95	34	1167	4,4	95	
17,0	165	1080	19,7	95	83	1200	10,9	95	53	1218	7,1	95	29	1218	4,0	95	
21,2	132	1035	15,1	95	66	1150	8,4	95	42	1167	5,5	95	24	1167	3,0	95	
24,6	114	1080	13,6	95	57	1200	7,5	95	37	1218	4,9	95	20	1218	2,7	95	
31,0	90	990	9,9	95	45	1100	5,5	95	29	1117	3,6	95	16,1	1117	2,0	95	
40,5	69	945	7,2	95	35	1050	4,0	95	22	1066	2,6	95	12,4	1066	1,5	95	
51,0	55	1035	6,3	95	27	1150	3,5	95	17,6	1167	2,3	95	9,8	1167	1,3	95	
58,0	48	900	4,8	95	24	1000	2,7	95	15,5	1015	1,7	95	8,6	1015	1,0	95	
73,2	38	900	3,8	95	19,1	1000	2,1	95	12,3	1015	1,4	95	6,8	1015	0,8	95	

Pt _N [kW]	tutti i rapporti all ratios alle Untersetzungen
	14.5

N.B. Per i riduttori evidenziati dal doppio bordo nella colonna delle potenze è necessario verificare lo scambio termico del riduttore (come indicato nel par. A-1.5). Per maggiori informazioni contattare l'ufficio tecnico STM.

*NOTE. Please pay attention to the frame around the input power value: for this gearboxes it's important to check the thermal capacity (comp. par. A-1.5). For details please contact our technical department).
For details please contact our technical*

HINWEIS. Sind in den Tabellen Nennleistungen eingerahmt, so ist die thermische Leistungsgrenze der Getriebe zu beachten (s. Kapitel A-1.5). Für weitere Informationen wenden Sie sich bitte an unser technisches Büro.

N.B. I pesi riportati sono indicativi e possono variare in funzione della versione del riduttore.

NOTE. Listed weights are for reference only and can vary according to the gearbox version.

HINWEIS. Die angegebenen Gewichtsmaße sind Richtwerte und können je nach Getriebeversion variieren.



OR 112



68.0

ir	$n_1 = 2800 \text{ min}^{-1}$				$n_1 = 1400 \text{ min}^{-1}$				$n_1 = 900 \text{ min}^{-1}$				$n_1 = 500 \text{ min}^{-1}$				IEC
	n_2	T_{2M}	P	RD	n_2	T_{2M}	P	RD	n_2	T_{2M}	P	RD	n_2	T_{2M}	P	RD	
	min^{-1}	Nm	kW	%	min^{-1}	Nm	kW	%	min^{-1}	Nm	kW	%	min^{-1}	Nm	kW	%	
7.7	366	540	23	90	183	670	14.3	90	118	760	10.4	90	65	800	6.1	90	160 B5 132 B5 112 B5 100 B5 90 B5 80 B5
8.9	315	580	21	90	157	715	13.1	90	101	810	9.5	90	56	850	5.5	90	
11.8	238	690	19.1	90	119	850	11.8	90	77	970	8.7	90	43	1000	5.0	90	
13.1	214	720	17.9	90	107	890	11.1	90	69	1000	8.0	90	38	1050	4.6	90	
16.1	174	940	19.0	90	87	1160	11.7	90	56	1300	8.5	90	31	1400	5.0	90	
17.9	156	1000	18.2	90	78	1230	11.2	90	50	1400	8.1	90	28	1450	4.7	90	
20.9	134	1040	16.2	90	67	1280	10.0	90	43	1460	7.3	90	24	1500	4.2	90	
22.3	126	1350	19.8	90	63	1750	12.8	90	40	1850	8.6	90	22	1900	4.9	90	
23.6	119	1100	15.2	90	59	1350	9.3	90	38	1540	6.8	90	21	1500	3.7	90	
25.6	109	1130	14.3	90	55	1400	9.0	90	35	1600	6.5	90	19.5	1600	3.6	90	
29.4	95	1420	15.7	90	48	1750	9.8	90	31	1900	6.9	90	17.0	1900	3.8	90	
32.8	85	1450	14.3	90	43	1750	8.8	90	27	1900	6.0	90	15.2	1900	3.4	90	
38.2	73	1450	12.3	90	37	1750	7.5	90	24	1900	5.3	90	13.1	1900	2.9	90	
43.2	65	1450	11.0	90	32	1750	6.5	90	21	1900	4.6	90	11.6	1900	2.6	90	
46.8	60	1450	10.1	90	30	1750	6.1	90	19.2	1900	4.2	90	10.7	1900	2.4	90	
53.4	52	1450	8.8	90	26	1750	5.3	90	16.9	1900	3.7	90	9.4	1900	2.1	90	
57.2	49	1450	8.3	90	24	1750	4.9	90	15.7	1900	3.5	90	8.7	1900	1.9	90	
64.6	43	1450	7.3	90	22	1750	4.5	90	13.9	1900	3.1	90	7.7	1900	1.7	90	
77.0	36	1450	6.1	90	18.2	1750	3.7	90	11.7	1900	2.6	90	6.5	1900	1.4	90	
85.4	33	1450	5.6	90	16.4	1750	3.3	90	10.5	1900	2.3	90	5.9	1900	1.3	90	
93.9	30	1450	5.1	90	14.9	1750	3.0	90	9.6	1900	2.1	90	5.3	1900	1.2	90	
102.8	27	1450	4.6	90	13.6	1750	2.8	90	8.8	1900	1.9	90	4.9	1900	1.1	90	
110.9	25	1450	4.2	90	12.6	1750	2.6	90	8.1	1900	1.8	90	4.5	1900	0.99	90	
125.2	22	1450	3.7	90	11.2	1750	2.3	90	7.2	1900	1.6	90	4.0	1900	0.88	90	
135.6	21	1450	3.5	90	10.3	1750	2.1	90	6.6	1900	1.5	90	3.7	1900	0.82	90	
154.8	18.1	1450	3.1	90	9.0	1750	1.8	90	5.8	1900	1.3	90	3.2	1900	0.71	90	
166.0	16.9	1450	2.9	90	8.4	1750	1.7	90	5.4	1900	1.2	90	3.0	1900	0.66	90	
194.9	14.4	1450	2.4	90	7.2	1750	1.5	90	4.6	1750	0.94	90	2.6	1750	0.53	90	
223.5	12.5	1450	2.1	90	6.3	1750	1.3	90	4.0	1900	0.88	90	2.2	1900	0.49	90	
247.9	11.3	1450	1.9	90	5.6	1750	1.1	90	3.6	1900	0.80	90	2.0	1900	0.44	90	
272.4	10.3	1450	1.7	90	5.1	1750	1.0	90	3.3	1900	0.73	90	1.8	1900	0.40	90	
298.1	9.4	1450	1.6	90	4.7	1750	0.96	90	3.0	1900	0.66	90	1.7	1900	0.38	90	
342.9	8.2	1450	1.4	90	4.1	1750	0.83	90	2.6	1750	0.53	90	1.5	1750	0.31	90	
375.3	7.5	1450	1.3	90	3.7	1750	0.75	90	2.4	1750	0.49	90	1.3	1750	0.26	90	

P_{tN} [kW]	tutti i rapporti all ratios alle Untersetzungen
	9.5

N.B. Per i riduttori evidenziati dal doppio bordo nella colonna delle potenze è necessario verificare lo scambio termico del riduttore (come indicato nel par. A-1.5). Per maggiori informazioni contattare l'ufficio tecnico STM.

NOTE. Please pay attention to the frame around the input power value: for this gearboxes it's important to check the thermal capacity (comp. par. A-1.5). For details please contact our technical department).
For details please contact our technical

HINWEIS. Sind in den Tabellen Nennleistungen eingerahmt, so ist die thermische Leistungsgrenze der Getriebe zu beachten (s. Kapitel A-1.5). Für weitere Informationen wenden Sie sich bitte an unser technisches Büro.

N.B. I pesi riportati sono indicativi e possono variare in funzione della versione del riduttore.

NOTE. Listed weights are for reference only and can vary according to the gearbox version.

HINWEIS. Die angegebenen Gewichtsmaße sind Richtwerte und können je nach Getriebeversion variieren.



OR 125

56.0

ir	$n_1 = 2800 \text{ min}^{-1}$				$n_1 = 1400 \text{ min}^{-1}$				$n_1 = 900 \text{ min}^{-1}$				$n_1 = 500 \text{ min}^{-1}$				IEC
	n_2	T_{2M}	P	RD	n_2	T_{2M}	P	RD	n_2	T_{2M}	P	RD	n_2	T_{2M}	P	RD	
	min^{-1}	Nm	kW	%	min^{-1}	Nm	kW	%	min^{-1}	Nm	kW	%	min^{-1}	Nm	kW	%	
5,2	544	900	53,9	95	272	1000	30,0	95	175	1015	19,5	95	97	1015	10,9	95	180 B5 160 B5 132 B5 132 B14 112 B5 100 B5 90 B5 80 B5
7,4	378	1170	48,7	95	189	1300	27,1	95	121	1320	17,7	95	67	1320	9,8	95	
10,2	276	1620	49,2	95	138	1800	27,3	95	89	1827	17,8	95	49	1827	9,9	95	
12,2	230	1710	43,4	95	115	1900	24,1	95	74	1929	15,7	95	41	1929	8,7	95	
14,6	191	1935	40,8	95	96	2150	22,7	95	61	2182	14,8	95	34	2182	8,2	95	
17,0	165	2070	37,7	95	83	2300	20,9	95	53	2335	13,7	95	29	2335	7,6	95	
21,2	132	1935	28,2	95	66	2150	15,6	95	42	2182	10,2	95	24	2182	5,7	95	
24,6	114	2070	26,0	95	57	2300	14,4	95	37	2335	9,4	95	20	2335	5,2	95	
31,9	88	2025	19,6	95	44	2250	10,9	95	28	2284	7,1	95	15,7	2284	3,9	95	
40,5	69	1845	14,1	95	35	2050	7,8	95	22	2081	5,1	95	12,4	2081	2,8	95	
52,6	53	2070	12,2	95	27	2300	6,8	95	17,1	2335	4,4	95	9,5	2335	2,4	95	
58,0	48	1800	9,6	95	24	2000	5,3	95	15,5	2030	3,5	95	8,6	2030	1,9	95	
75,4	37	1800	7,4	95	18,6	2000	4,1	95	11,9	2030	2,7	95	6,6	2030	1,5	95	

P_{tN} [kW]	tutti i rapporti all ratios alle Untersetzungen
	20.0

N.B. Per i riduttori evidenziati dal doppio bordo nella colonna delle potenze è necessario verificare lo scambio termico del riduttore (come indicato nel par. A-1.5). Per maggiori informazioni contattare l'ufficio tecnico STM.

*NOTE. Please pay attention to the frame around the input power value: for this gearboxes it's important to check the thermal capacity (comp. par. A-1.5). For details please contact our technical department).
For details please contact our technical*

HINWEIS. Sind in den Tabellen Nennleistungen eingerahmt, so ist die thermische Leistungsgrenze der Getriebe zu beachten (s. Kapitel A-1.5). Für weitere Informationen wenden Sie sich bitte an unser technisches Büro.

N.B. I pesi riportati sono indicativi e possono variare in funzione della versione del riduttore.

NOTE. Listed weights are for reference only and can vary according to the gearbox version.

HINWEIS. Die angegebenen Gewichtsmaße sind Richtwerte und können je nach Getriebeversion variieren.



OR 132



ir	$n_1 = 2800 \text{ min}^{-1}$				$n_1 = 1400 \text{ min}^{-1}$				$n_1 = 900 \text{ min}^{-1}$				$n_1 = 500 \text{ min}^{-1}$				IEC	
	n_2	T_{2M}	P	RD	n_2	T_{2M}	P	RD	n_2	T_{2M}	P	RD	n_2	T_{2M}	P	RD		
	min^{-1}	Nm	kW	%	min^{-1}	Nm	kW	%	min^{-1}	Nm	kW	%	min^{-1}	Nm	kW	%		
16.0	175.3	1530.0	30.2	93.0	87.7	1700.0	16.8	93.0	56.3	1725.5	10.9	93.0	31.3	1725.5	6.1	93.0	90 B5	
17.9	156.1	1620.0	28.5	93.0	78.0	1800.0	15.8	93.0	50.2	1827.0	10.3	93.0	27.9	1827.0	5.7	93.0		100 B5
20.3	138.3	1800.0	28.0	93.0	69.1	2000.0	15.6	93.0	44.4	2030.0	10.2	93.0	24.7	2030.0	5.6	93.0		
21.7	129.3	1980.0	28.8	93.0	64.7	2200.0	16.0	93.0	41.6	2233.0	10.5	93.0	23.1	2233.0	5.8	93.0		132 B5
24.3	115.1	2070.0	26.8	93.0	57.6	2300.0	14.9	93.0	37.0	2334.5	9.7	93.0	20.6	2334.5	5.4	93.0		
27.5	102.0	2412.0	27.7	93.0	51.0	2680.0	15.4	93.0	32.8	2720.2	10.0	93.0	18.2	2720.2	5.6	93.0		180 B5
31.2	89.8	2835.0	28.7	93.0	44.9	3150.0	15.9	93.0	28.9	3197.3	10.4	93.0	16.0	3197.3	5.8	93.0		
36.3	77.2	3150.0	27.4	93.0	38.6	3500.0	15.2	93.0	24.8	3552.5	9.9	93.0	13.8	3552.5	5.5	93.0		180 B5
41.7	67.1	3150.0	23.8	93.0	33.5	3500.0	13.2	93.0	21.6	3552.5	8.6	93.0	12.0	3552.5	4.8	93.0		
44.9	62.3	3150.0	22.1	93.0	31.2	3500.0	12.3	93.0	20.0	3552.5	8.0	93.0	11.1	3552.5	4.5	93.0		180 B5
52.6	53.2	3150.0	18.9	93.0	26.6	3500.0	10.5	93.0	17.1	3552.5	6.8	93.0	9.5	3552.5	3.8	93.0		
57.3	48.9	3150.0	17.3	93.0	24.4	3500.0	9.6	93.0	15.7	3552.5	6.3	93.0	8.7	3552.5	3.5	93.0		180 B5
65.1	43.0	3150.0	15.2	93.0	21.5	3500.0	8.5	93.0	13.8	3552.5	5.5	93.0	7.7	3552.5	3.1	93.0		
76.3	36.7	3150.0	13.0	93.0	18.4	3500.0	7.2	93.0	11.8	3552.5	4.7	93.0	6.6	3552.5	2.6	93.0		180 B5
83.0	33.7	3150.0	12.0	93.0	16.9	3500.0	6.6	93.0	10.8	3552.5	4.3	93.0	6.0	3552.5	2.4	93.0		
90.8	30.8	3150.0	10.9	93.0	15.4	3500.0	6.1	93.0	9.9	3552.5	4.0	93.0	5.5	3552.5	2.2	93.0		180 B5
99.4	28.2	3150.0	10.0	93.0	14.1	3500.0	5.5	93.0	9.1	3552.5	3.6	93.0	5.0	3552.5	2.0	93.0		
109.4	25.6	3150.0	9.1	93.0	12.8	3500.0	5.0	93.0	8.2	3552.5	3.3	93.0	4.6	3552.5	1.8	93.0		180 B5
125.5	22.3	3150.0	7.9	93.0	11.2	3500.0	4.4	93.0	7.2	3552.5	2.9	93.0	4.0	3552.5	1.6	93.0		
136.7	20.5	3150.0	7.3	93.0	10.2	3500.0	4.0	93.0	6.6	3552.5	2.6	93.0	3.7	3552.5	1.5	93.0		180 B5
149.5	18.7	3150.0	6.6	93.0	9.4	3500.0	3.7	93.0	6.0	3552.5	2.4	93.0	3.3	3552.5	1.3	93.0	180 B5	
164.6	17.0	3150.0	6.0	93.0	8.5	3500.0	3.4	93.0	5.5	3552.5	2.2	93.0	3.0	3552.5	1.2	93.0		180 B5
180.0	15.6	3150.0	5.5	93.0	7.8	3500.0	3.1	93.0	5.0	3552.5	2.0	93.0	2.8	3552.5	1.1	93.0	180 B5	

Pt _N [kW]	tutti i rapporti all ratios alle Untersetzungen
	23.0

N.B. Per i riduttori evidenziati dal doppio bordo nella colonna delle potenze è necessario verificare lo scambio termico del riduttore (come indicato nel par. A-1.5). Per maggiori informazioni contattare l'ufficio tecnico STM.

NOTE. Please pay attention to the frame around the input power value: for this gearboxes it's important to check the thermal capacity (comp. par. A-1.5). For details please contact our technical department).
For details please contact our technical

HINWEIS. Sind in den Tabellen Nennleistungen eingerahmt, so ist die thermische Leistungsgrenze der Getriebe zu beachten (s. Kapitel A-1.5). Für weitere Informationen wenden Sie sich bitte an unser technisches Büro.

N.B. I pesi riportati sono indicativi e possono variare in funzione della versione del riduttore.

NOTE. Listed weights are for reference only and can vary according to the gearbox version.

HINWEIS. Die angegebenen Gewichtsmaße sind Richtwerte und können je nach Getriebeversion variieren.



OR 140

110.0

ir	$n_1 = 2800 \text{ min}^{-1}$				$n_1 = 1400 \text{ min}^{-1}$				$n_1 = 900 \text{ min}^{-1}$				$n_1 = 500 \text{ min}^{-1}$				IEC
	n_2	T_{2M}	P	RD	n_2	T_{2M}	P	RD	n_2	T_{2M}	P	RD	n_2	T_{2M}	P	RD	
	min^{-1}	Nm	kW	%	min^{-1}	Nm	kW	%	min^{-1}	Nm	kW	%	min^{-1}	Nm	kW	%	
7,6	369	3600	146,4	95	184	4000	81,3	95	119	4060	53,1	95	66	4060	29,5	95	200 B5 180 B5 160 B5 132 B5 132 B14 112 B5 100 B5 90 B5 80 B5
10,3	272	3600	108,0	95	136	4000	60,0	95	87	4060	39,2	95	49	4060	21,8	95	
12,3	228	3690	92,9	95	114	4100	51,6	95	73	4162	33,7	95	41	4162	18,7	95	
14,9	187	3780	78,1	95	94	4200	43,4	95	60	4263	28,3	95	33	4263	15,7	95	
20,2	139	3780	57,8	95	69	4200	32,1	95	45	4263	20,9	95	25	4263	11,6	95	
24,6	114	3870	48,5	95	57	4300	27,0	95	37	4365	17,6	95	20	4365	9,8	95	
33,4	84	3960	36,6	95	42	4400	20,3	95	27	4466	13,3	95	15,0	4466	7,4	95	
40,7	69	3690	28,0	95	34	4100	15,5	95	22	4162	10,1	95	12,3	4162	5,6	95	
51,3	55	4050	24,4	95	27	4500	13,5	95	17,5	4568	8,8	95	9,7	4568	4,9	95	
57,4	49	3780	20,3	95	24	4200	11,3	95	15,7	4263	7,4	95	8,7	4263	4,1	95	
72,3	39	3600	15,4	95	19	4000	8,5	95	12,4	4060	5,6	95	6,9	4060	3,1	95	

P_{tN} [kW]	tutti i rapporti all ratios alle Untersetzungen
	32.0

N.B. Per i riduttori evidenziati dal doppio bordo nella colonna delle potenze è necessario verificare lo scambio termico del riduttore (come indicato nel par. A-1.5). Per maggiori informazioni contattare l'ufficio tecnico STM.

*NOTE. Please pay attention to the frame around the input power value: for this gearboxes it's important to check the thermal capacity (comp. par. A-1.5). For details please contact our technical department).
For details please contact our technical*

HINWEIS. Sind in den Tabellen Nennleistungen eingerahmt, so ist die thermische Leistungsgrenze der Getriebe zu beachten (s. Kapitel A-1.5). Für weitere Informationen wenden Sie sich bitte an unser technisches Büro.

N.B. I pesi riportati sono indicativi e possono variare in funzione della versione del riduttore.

NOTE. Listed weights are for reference only and can vary according to the gearbox version.

HINWEIS. Die angegebenen Gewichtsmaße sind Richtwerte und können je nach Getriebeversion variieren.



OR 150



ir	$n_1 = 2800 \text{ min}^{-1}$				$n_1 = 1400 \text{ min}^{-1}$				$n_1 = 900 \text{ min}^{-1}$				$n_1 = 500 \text{ min}^{-1}$				IEC
	n_2	T_{2M}	P	RD	n_2	T_{2M}	P	RD	n_2	T_{2M}	P	RD	n_2	T_{2M}	P	RD	
	min^{-1}	Nm	kW	%	min^{-1}	Nm	kW	%	min^{-1}	Nm	kW	%	min^{-1}	Nm	kW	%	
15.7	178.2	2430.0	48.8	93.0	89.1	2700.0	27.1	93.0	57.3	2740.5	17.7	93.0	31.8	2740.5	9.8	93.0	100 B5 112 B5 132 B5 160 B5 180 B5 200 B5
18.6	150.3	2880.0	48.7	93.0	75.1	3200.0	27.1	93.0	48.3	3248.0	17.7	93.0	26.8	3248.0	9.8	93.0	
21.6	129.9	3510.0	51.3	93.0	65.0	3900.0	28.5	93.0	41.8	3958.5	18.6	93.0	23.2	3958.5	10.3	93.0	
22.9	122.5	3780.0	52.1	93.0	61.2	4200.0	29.0	93.0	39.4	4263.0	18.9	93.0	21.9	4263.0	10.5	93.0	
25.9	108.3	4050.0	49.4	93.0	54.2	4500.0	27.4	93.0	34.8	4567.5	17.9	93.0	19.3	4567.5	9.9	93.0	
30.3	92.4	4500.0	46.8	93.0	46.2	5000.0	26.0	93.0	29.7	5075.0	17.0	93.0	16.5	5075.0	9.4	93.0	
34.5	81.2	4500.0	41.1	93.0	40.6	5000.0	22.9	93.0	26.1	5075.0	14.9	93.0	14.5	5075.0	8.3	93.0	
36.9	75.8	4500.0	38.4	93.0	37.9	5000.0	21.3	93.0	24.4	5075.0	13.9	93.0	13.5	5075.0	7.7	93.0	
42.6	65.7	4500.0	33.3	93.0	32.8	5000.0	18.5	93.0	21.1	5075.0	12.1	93.0	11.7	5075.0	6.7	93.0	
46.0	60.8	4500.0	30.8	93.0	30.4	5000.0	17.1	93.0	19.5	5075.0	11.2	93.0	10.9	5075.0	6.2	93.0	
54.3	51.6	4500.0	26.1	93.0	25.8	5000.0	14.5	93.0	16.6	5075.0	9.5	93.0	9.2	5075.0	5.3	93.0	
59.4	47.2	4500.0	23.9	93.0	23.6	5000.0	13.3	93.0	15.2	5075.0	8.7	93.0	8.4	5075.0	4.8	93.0	
66.7	42.0	4500.0	21.3	93.0	21.0	5000.0	11.8	93.0	13.5	5075.0	7.7	93.0	7.5	5075.0	4.3	93.0	
78.7	35.6	4500.0	18.0	93.0	17.8	5000.0	10.0	93.0	11.4	5075.0	6.5	93.0	6.4	5075.0	3.6	93.0	
86.0	32.5	4500.0	16.5	93.0	16.3	5000.0	9.2	93.0	10.5	5075.0	6.0	93.0	5.8	5075.0	3.3	93.0	
94.6	29.6	4500.0	15.0	93.0	14.8	5000.0	8.3	93.0	9.5	5075.0	5.4	93.0	5.3	5075.0	3.0	93.0	
101.7	27.5	4500.0	13.9	93.0	13.8	5000.0	7.7	93.0	8.8	5075.0	5.1	93.0	4.9	5075.0	2.8	93.0	
109.8	25.5	4500.0	12.9	93.0	12.8	5000.0	7.2	93.0	8.2	5075.0	4.7	93.0	4.6	5075.0	2.6	93.0	
129.5	21.6	4500.0	11.0	93.0	10.8	5000.0	6.1	93.0	7.0	5075.0	4.0	93.0	3.9	5075.0	2.2	93.0	
141.6	19.8	4500.0	10.0	93.0	9.9	5000.0	5.6	93.0	6.4	5075.0	3.6	93.0	3.5	5075.0	2.0	93.0	
155.7	18.0	4500.0	9.1	93.0	9.0	5000.0	5.1	93.0	5.8	5075.0	3.3	93.0	3.2	5075.0	1.8	93.0	
185.5	15.1	4320.0	7.3	93.0	7.5	4800.0	4.1	93.0	4.9	4872.0	2.7	93.0	2.7	4872.0	1.5	93.0	
204.2	13.7	4140.0	6.4	93.0	6.9	4600.0	3.6	93.0	4.4	4669.0	2.3	93.0	2.4	4669.0	1.3	93.0	

P_{tN} [kW]	tutti i rapporti all ratios alle Untersetzungen
	28.0

N.B. Per i riduttori evidenziati dal doppio bordo nella colonna delle potenze è necessario verificare lo scambio termico del riduttore (come indicato nel par. A-1.5). Per maggiori informazioni contattare l'ufficio tecnico STM.

NOTE. Please pay attention to the frame around the input power value: for this gearboxes it's important to check the thermal capacity (comp. par. A-1.5). For details please contact our technical department).
For details please contact our technical

HINWEIS. Sind in den Tabellen Nennleistungen eingerahmt, so ist die thermische Leistungsgrenze der Getriebe zu beachten (s. Kapitel A-1.5). Für weitere Informationen wenden Sie sich bitte an unser technisches Büro.

N.B. I pesi riportati sono indicativi e possono variare in funzione della versione del riduttore.

NOTE. Listed weights are for reference only and can vary according to the gearbox version.

HINWEIS. Die angegebenen Gewichtsmaße sind Richtwerte und können je nach Getriebeversion variieren.



OR 170



ir	n ₁ = 2800 min ⁻¹				n ₁ = 1400 min ⁻¹				n ₁ = 900 min ⁻¹				n ₁ = 500 min ⁻¹				IEC
	n ₂	T _{2M}	P	RD	n ₂	T _{2M}	P	RD	n ₂	T _{2M}	P	RD	n ₂	T _{2M}	P	RD	
	min ⁻¹	Nm	kW	%	min ⁻¹	Nm	kW	%	min ⁻¹	Nm	kW	%	min ⁻¹	Nm	kW	%	
15.5	180.9	4140.0	84.3	93.0	90.4	4600.0	46.8	93.0	58.1	4669.0	30.6	94.0	32.3	4669.0	17.0	93.0	100 B5 112 B5 132 B5 160 B5 180 B5 200 B5 225 B5
17.5	160.1	4500.0	81.1	93.0	80.1	5000.0	45.1	93.0	51.5	5075.0	29.4	94.0	28.6	5075.0	16.3	93.0	
18.6	150.3	5040.0	85.3	93.0	75.2	5600.0	47.4	93.0	48.3	5684.0	30.9	94.0	26.8	5684.0	17.2	93.0	
23.7	118.1	6300.0	83.8	93.0	59.1	7000.0	46.6	93.0	38.0	7105.0	30.4	94.0	21.1	7105.0	16.9	93.0	
25.2	110.9	6750.0	84.3	93.0	55.4	7500.0	46.8	93.0	35.6	7612.5	30.6	94.0	19.8	7612.5	17.0	93.0	
28.8	97.2	6750.0	73.9	93.0	48.6	7500.0	41.0	93.0	31.2	7612.5	26.8	94.0	17.4	7612.5	14.9	93.0	
30.9	90.7	6750.0	69.0	93.0	45.4	7500.0	38.3	93.0	29.2	7612.5	25.0	94.0	16.2	7612.5	13.9	93.0	
35.7	78.4	6750.0	59.6	93.0	39.2	7500.0	33.1	93.0	25.2	7612.5	21.6	94.0	14.0	7612.5	12.0	93.0	
41.8	66.9	6750.0	50.9	93.0	33.5	7500.0	28.3	93.0	21.5	7612.5	18.4	94.0	12.0	7612.5	10.2	93.0	
45.6	61.5	6750.0	46.7	93.0	30.7	7500.0	26.0	93.0	19.8	7612.5	16.9	94.0	11.0	7612.5	9.4	93.0	
49.8	56.2	6750.0	42.7	93.0	28.1	7500.0	23.7	93.0	18.1	7612.5	15.5	94.0	10.0	7612.5	8.6	93.0	
54.3	51.6	6750.0	39.2	93.0	25.8	7500.0	21.8	93.0	16.6	7612.5	14.2	94.0	9.2	7612.5	7.9	93.0	
64.0	43.7	6750.0	33.2	93.0	21.9	7500.0	18.5	93.0	14.1	7612.5	12.0	94.0	7.8	7612.5	6.7	93.0	
68.9	40.6	6750.0	30.9	93.0	20.3	7500.0	17.2	93.0	13.1	7612.5	11.2	94.0	7.3	7612.5	6.2	93.0	
75.0	37.3	6750.0	28.4	93.0	18.7	7500.0	15.8	93.0	12.0	7612.5	10.3	94.0	6.7	7612.5	5.7	93.0	
81.7	34.3	6750.0	26.0	93.0	17.1	7500.0	14.5	93.0	11.0	7612.5	9.4	94.0	6.1	7612.5	5.2	93.0	
89.4	31.3	6750.0	23.8	93.0	15.7	7500.0	13.2	93.0	10.1	7612.5	8.6	94.0	5.6	7612.5	4.8	93.0	
98.4	28.5	6750.0	21.6	93.0	14.2	7500.0	12.0	93.0	9.1	7612.5	7.8	94.0	5.1	7612.5	4.4	93.0	
113.9	24.6	6750.0	18.7	93.0	12.3	7500.0	10.4	93.0	7.9	7612.5	6.8	94.0	4.4	7612.5	3.8	93.0	
124.1	22.6	6750.0	17.2	93.0	11.3	7500.0	9.5	93.0	7.3	7612.5	6.2	94.0	4.0	7612.5	3.5	93.0	
135.8	20.6	6750.0	15.7	93.0	10.3	7500.0	8.7	93.0	6.6	7612.5	5.7	94.0	3.7	7612.5	3.2	93.0	
149.4	18.7	6750.0	14.2	93.0	9.4	7500.0	7.9	93.0	6.0	7612.5	5.2	94.0	3.3	7612.5	2.9	93.0	
162.7	17.2	6750.0	13.1	93.0	8.6	7500.0	7.3	93.0	5.5	7612.5	4.7	94.0	3.1	7612.5	2.6	93.0	
178.1	15.7	6210.0	11.0	93.0	7.9	6900.0	6.1	93.0	5.1	7003.5	4.0	94.0	2.8	7003.5	2.2	93.0	
196.0	14.3	5940.0	9.6	93.0	7.1	6600.0	5.3	93.0	4.6	6699.0	3.5	94.0	2.6	6699.0	1.9	93.0	

Pt _N [kW]	tutti i rapporti all ratios alle Untersetzungen
	34.0

N.B. Per i riduttori evidenziati dal doppio bordo nella colonna delle potenze è necessario verificare lo scambio termico del riduttore (come indicato nel par. A-1.5). Per maggiori informazioni contattare l'ufficio tecnico STM.

*NOTE. Please pay attention to the frame around the input power value: for this gearboxes it's important to check the thermal capacity (comp. par. A-1.5). For details please contact our technical department).
For details please contact our technical*

HINWEIS. Sind in den Tabellen Nennleistungen eingerahmt, so ist die thermische Leistungsgrenze der Getriebe zu beachten (s. Kapitel A-1.5). Für weitere Informationen wenden Sie sich bitte an unser technisches Büro.

N.B. I pesi riportati sono indicativi e possono variare in funzione della versione del riduttore.

NOTE. Listed weights are for reference only and can vary according to the gearbox version.

HINWEIS. Die angegebenen Gewichtsmaße sind Richtwerte und können je nach Getriebeversion variieren.



OR 190



250

ir	n ₁ = 2800 min ⁻¹				n ₁ = 1400 min ⁻¹				n ₁ = 900 min ⁻¹				n ₁ = 500 min ⁻¹				IEC
	n ₂	T _{2M}	P	RD	n ₂	T _{2M}	P	RD	n ₂	T _{2M}	P	RD	n ₂	T _{2M}	P	RD	
	min ⁻¹	Nm	kW	%	min ⁻¹	Nm	kW	%	min ⁻¹	Nm	kW	%	min ⁻¹	Nm	kW	%	
15.5	180.9	5796.0	118.0	93.0	90.4	6440.0	65.6	93.0	58.1	6537	42.8	93.0	32.3	6537	23.8	93.0	132 B5 160 B5 180 B5 200 B5 225 B5 250 B5
17.5	160.1	6300.0	113.6	93.0	80.1	7000.0	63.1	93.0	51.5	7105	41.2	93.0	28.6	7105	22.9	93.0	
18.6	150.3	7056.0	119.4	93.0	75.2	7840.0	66.4	93.0	48.3	7958	43.3	93.0	26.8	7958	24.1	93.0	
23.7	118.1	8640.0	114.9	93.0	59.1	9600.0	63.8	93.0	38.0	9744	41.7	93.0	21.1	9744	23.1	93.0	
25.2	110.9	8820.0	110.1	93.0	55.4	9800.0	61.2	93.0	35.6	9947	39.9	93.0	19.8	9947	22.2	93.0	
28.8	97.2	9000.0	98.5	93.0	48.6	10000.0	54.7	93.0	31.2	10150	35.7	93.0	17.4	10150	19.8	93.0	
30.9	90.7	9225.0	94.2	93.0	45.4	10250.0	52.4	93.0	29.2	10404	34.2	93.0	16.2	10404	19.0	93.0	
35.7	78.4	9450.0	83.5	93.0	39.2	10500.0	46.4	93.0	25.2	10658	30.3	93.0	14.0	10658	16.8	93.0	
41.8	66.9	9450.0	71.2	93.0	33.5	10500.0	39.6	93.0	21.5	10658	25.8	93.0	12.0	10658	14.3	93.0	
45.6	61.5	9450.0	65.4	93.0	30.7	10500.0	36.3	93.0	19.8	10658	23.7	93.0	11.0	10658	13.2	93.0	
49.8	56.2	9450.0	59.8	93.0	28.1	10500.0	33.2	93.0	18.1	10658	21.7	93.0	10.0	10658	12.0	93.0	
54.3	51.6	9450.0	54.9	93.0	25.8	10500.0	30.5	93.0	16.6	10658	19.9	93.0	9.2	10658	11.1	93.0	
64.0	43.7	9450.0	46.5	93.0	21.9	10500.0	25.8	93.0	14.1	10658	16.9	93.0	7.8	10658	9.4	93.0	
68.9	40.6	9450.0	43.2	93.0	20.3	10500.0	24.0	93.0	13.1	10658	15.7	93.0	7.3	10658	8.7	93.0	
75.0	37.3	9450.0	39.7	93.0	18.7	10500.0	22.1	93.0	12.0	10658	14.4	93.0	6.7	10658	8.0	93.0	
81.7	34.3	9450.0	36.5	93.0	17.1	10500.0	20.3	93.0	11.0	10658	13.2	93.0	6.1	10658	7.3	93.0	
89.4	31.3	9450.0	33.3	93.0	15.7	10500.0	18.5	93.0	10.1	10658	12.1	93.0	5.6	10658	6.7	93.0	
97.9	28.6	9450.0	30.4	93.0	14.3	10500.0	16.9	93.0	9.2	10658	11.0	93.0	5.1	10658	6.1	93.0	
113.9	24.6	9450.0	26.2	93.0	12.3	10500.0	14.5	93.0	7.9	10658	9.5	93.0	4.4	10658	5.3	93.0	
124.1	22.6	9450.0	24.0	93.0	11.3	10500.0	13.3	93.0	7.3	10658	8.7	93.0	4.0	10658	4.8	93.0	
135.8	20.6	9450.0	21.9	93.0	10.3	10500.0	12.2	93.0	6.6	10658	8.0	93.0	3.7	10658	4.4	93.0	
147.8	18.9	9450.0	20.2	93.0	9.5	10500.0	11.2	93.0	6.1	10658	7.3	93.0	3.4	10658	4.1	93.0	
162.7	17.2	9450.0	18.3	93.0	8.6	10500.0	10.2	93.0	5.5	10658	6.6	93.0	3.1	10658	3.7	93.0	
178.1	15.7	9225.0	16.3	93.0	7.9	10250.0	9.1	93.0	5.1	10404	5.9	93.0	2.8	10404	3.3	93.0	
196.0*	14.3	9000.0	14.5	93.0	7.1	10000.0	8.0	93.0	4.6	10150	5.2	93.0	2.6	10150	2.9	93.0	

Pt _N [kW]	tutti i rapporti all ratios alle Untersetzungen
	43.0

* Nei rapporti contrassegnati non è disponibile la versione uscita con albero cavo.

* *Hollow output shaft not available for ratios marked with this symbol.*

* Bei den gekennzeichneten Übersetzungsverhältnissen ist die Version „Abtrieb mit Hohlwelle“ nicht verfügbar.

N.B. Per i riduttori evidenziati dal doppio bordo nella colonna delle potenze è necessario verificare lo scambio termico del riduttore (come indicato nel par. A-1.5). Per maggiori informazioni contattare l'ufficio tecnico STM.

NOTE. Please pay attention to the frame around the input power value: for this gearboxes it's important to check the thermal capacity (comp. par. A-1.5). For details please contact our technical department). For details please contact our technical

HINWEIS. Sind in den Tabellen Nennleistungen eingerahmt, so ist die thermische Leistungsgrenze der Getriebe zu beachten (s. Kapitel A-1.5). Für weitere Informationen wenden Sie sich bitte an unser technisches Büro.

N.B. I pesi riportati sono indicativi e possono variare in funzione della versione del riduttore.

NOTE. Listed weights are for reference only and can vary according to the gearbox version.

HINWEIS. Die angegebenen Gewichtsmaße sind Richtwerte und können je nach Getriebeversion variieren.



Nella tab. 3.6 sono riportate le grandezze motore accoppiabili (IEC) unitamente alle dimensioni albero/flangia motore standard.

In table 3.6 the possible shaft/flange dimensions IEC standard are listed.

In Tabelle 3.6 sind die verfügbaren IEC-Standardmotoreingänge mit den Wellen- u. Flanschabmessungen aufgelistet.

Tab.3.6

Possibili accoppiamenti con motori IEC-Possible couplings with IEC motors-Mögliche Verbindungen mit IEC-Motoren		
IEC	ir	
	Tutti / All / Alle	
63	63	11/140 (B5)
	71	14/160 (B5)
	80	19/200 (B5) - 19/120 (B14) - 19/160 - 19/140
	90	24/200 (B5) - 24/140 (B14) - 24/160 - 24/120
	100	28/250 (B5) - 28/160 (B14)
71	63	11/140 (B5)
	71	14/160 (B5) - 14/200 - 14/140 - 14/120
	80	19/200 (B5) - 19/120 (B14) - 19/160 - 19/140
	90	24/200 (B5) - 24/140 (B14) - 24/160 - 24/120
	100	28/250 (B5) - 28/160 (B14)
80	112	28/250 (B5) - 28/160 (B14)
	71	14/160 (B5) - 14/250 - 14/200 - 14/140 - 14/120
	80	19/200 (B5) - 19/120 (B14) - 19/250 - 19/160 - 19/140
	90	24/200 (B5) - 24/140 (B14) - 24/250 - 24/160 - 24/120
	100	28/250 (B5) - 28/160 (B14) - 28/200 - 28/140 - 28/120
90	112	28/250 (B5) - 28/160 (B14) - 28/200 - 28/140 - 28/120
	71	14/160 (B5)
	80	19/200 (B5) - 19/120 (B14) - 19/160 - 19/140
	90	24/200 (B5) - 24/140 (B14) - 24/300 - 24/250 - 24/160 - 24/120
	100	28/250 (B5) - 28/160 (B14) - 28/200 - 28/300
100	112	28/250 (B5) - 28/160 (B14) - 28/200 - 28/300
	132	38/300 (B5) - 38/200 (B14) - 38/250
	80	19/200 (B5) - 19/300 - 19/250
	90	24/200 (B5) - 24/300 - 24/250
	100	28/250 (B5) - 28/300 - 28/200
112	112	28/250 (B5) - 28/300 - 28/200
	132	38/300 (B5) - 38/350 - 38/250
	160*	42/350 (B5) - 42/300 - 42/250
	180*	48/350 (B5)
	125	80
90		24/200 (B5) - 24/300 - 24/250
100		28/250 (B5) - 28/300 - 28/200
112		28/250 (B5) - 28/300 - 28/200
132		38/300 (B5) - 38/200 (B14) - 38/250

Possibili accoppiamenti con motori IEC-Possible couplings with IEC motors-Mögliche Verbindungen mit IEC-Motoren		
IEC	ir	
	Tutti / All / Alle	
132	90	24/200 (B5)
	100	28/250 (B5)
	112	28/250 (B5)
	132	38/300 (B5)
	160*	42/350 (B5)
140	180*	48/350 (B5)
	80	19/200 (B5)
	90	24/200 (B5) - 24/300 - 24/250
	100	28/250 (B5) - 28/300 - 28/200
	112	28/250 (B5) - 28/300 - 28/200
150	132	38/300 (B5) - 38/200 (B14) - 38/250
	160*	42/350 (B5)
	180*	48/350 (B5)
	200*	55/400 (B5)
	100	28/250 (B5)
170	112	28/250 (B5)
	132	38/300 (B5)
	160*	42/350 (B5)
	180*	48/350 (B5)
	200*	55/400 (B5)
190	225*	60/450 (B5)
	132	38/300 (B5)
	160*	42/350 (B5)
	180*	48/350 (B5)
	200*	55/400 (B5)
225*	60/450 (B5)	
250*	65/550 (B5)	

Legenda:

19/200 (B5) 19/160

19/200 : combinazioni albero/flangia standard (B5) : forma costruttiva motore IEC
19/160 : combinazione albero/flangia a richiesta

Key:

19/200 (B5) 19/160

19/200 : standard shaft/flange combination (B5) : IEC motor constructive shape
19/160 : shaft/flange combinations upon request

Legende:

19/200 (B5) 19/160

19/200 : Standardkombinationen Welle/Flansch (B5) : Konstruktionsform IEC-Motor
19/160 : Sonderkombinationen Welle/Flansch

* Tutti i PAM sono forniti con giunto ROTEX. Per i PAM segnati da asterisco vedere le prescrizioni (per prescrizioni di montaggio vedere sezione A paragrafo "Installazione")

* All PAM configurations supplied with ROTEX coupling. Where PAM configuration is marked with an asterisk, see directions (for mounting directions, see section A, paragraph "Installation")

* Alle PAM werden sie mit Kupplung Typ ROTEX geliefert. Bei den mit einem Sternchen gekennzeichneten PAM siehe Vorgaben (hinsichtlich Montagegenauigkeit siehe Abschnitt A im Paragraph "Einbau").



1.7 Prestazioni motoriduttori

n_2 min ⁻¹	ir	T2 Nm	FS'	OM-OC	
----------------------------	----	----------	-----	-------	--

0.09 kW	$n_1 = 860 \text{ min}^{-1}$	63B 6
----------------	------------------------------	-------

44	19.5	18	14.0	63	63B 6
31	27.5	25	10.5	63	63B 6
28	31.2	28	9.3	63	63B 6
24	35.8	32	8.1	63	63B 6
19.3	44.6	40	6.5	63	63B 6
16.4	52.4	47	5.5	63	63B 6
12.5	69.0	62	4.2	63	63B 6
10.8	79.5	71	3.6	63	63B 6
9.5	90.6	82	3.1	63	63B 6
8.3	103.8	93	2.7	63	63B 6
6.7	129.3	116	2.2	63	63B 6
5.7	151.9	137	1.9	63	63B 6
4.8	179.6	162	3.2	71	63B 6
4.4	193.6	174	3.0	71	63B 6
4.3	200.1	180	1.4	63	63B 6
3.9	220.8	199	2.6	71	63B 6
3.5	243.3	219	1.2	63	63B 6
3.4	253.4	228	2.3	71	63B 6
3.1	280.4	252	1.1	63	63B 6
3.0	286.0	257	2.0	71	63B 6
2.5	342.9	308	1.7	71	63B 6
2.5	346.4	312	0.9	63	63B 6
2.2	387.0	348	1.5	71	63B 6

0.13 kW	$n_1 = 1360 \text{ min}^{-1}$ $n_1 = 860 \text{ min}^{-1}$	63A 4 63C 6
----------------	---	----------------

57	23.7	20	12.3	63	63A 4
50	27.5	23	10.6	63	63A 4
44	30.6	25	18.3	71	63A 4
44	31.2	26	9.3	63	63A 4
38	35.8	29	8.5	63	63A 4
31	44.6	37	6.8	63	63A 4
26	52.4	43	5.8	63	63A 4
19.7	69.0	57	4.4	63	63A 4
17.1	79.5	65	3.8	63	63A 4
15.0	90.6	74	3.1	63	63A 4
13.1	103.8	85	2.8	63	63A 4
10.5	129.3	106	2.3	63	63A 4
9.0	151.9	125	2.0	63	63A 4
8.1	168.0	138	3.3	71	63A 4
7.6	179.6	148	3.1	71	63A 4
7.0	193.6	159	2.9	71	63A 4
6.8	200.1	164	1.5	63	63A 4
6.5	209.4	172	2.7	71	63A 4
6.2	220.8	181	2.5	71	63A 4
5.6	243.3	200	1.3	63	63A 4
5.4	253.4	208	2.2	71	63A 4
4.8	280.4	230	1.1	63	63A 4
4.6	298.8	245	1.9	71	63A 4
4.0	342.9	282	1.6	71	63A 4
3.9	346.4	285	0.9	63	63A 4
3.5	387.0	318	1.4	71	63A 4
2.9	298.8	388	1.4	71	63C 6
2.5	342.9	445	1.2	71	63C 6
2.2	387.0	503	1.0	71	63C 6

1.7 Gearmotors performances

n_2 min ⁻¹	ir	T2 Nm	FS'	OM-OC	
----------------------------	----	----------	-----	-------	--

0.18 kW	$n_1 = 1370 \text{ min}^{-1}$ $n_1 = 870 \text{ min}^{-1}$	63B 4 71A 6
----------------	---	----------------

92	14.8	17	13.1	63	63B 4
80	17.2	19	11.4	63	63B 4
70	19.5	22	10.4	63	63B 4
58	23.7	27	9.0	63	63B 4
50	27.5	31	7.7	63	63B 4
44	31.2	35	6.8	63	63B 4
38	35.8	40	6.2	63	63B 4
31	44.6	50	5.0	63	63B 4
26	52.4	59	4.2	63	63B 4
19.9	69.0	78	3.2	63	63B 4
17.2	79.5	90	2.8	63	63B 4
15.1	90.6	102	2.2	63	63B 4
13.2	103.8	117	2.0	63	63B 4
11.1	123.5	139	3.3	71	63B 4
10.6	129.3	146	1.6	63	63B 4
9.6	143.1	162	2.8	71	63B 4
9.0	151.9	172	1.4	63	63B 4
8.9	154.8	175	2.6	71	63B 4
8.2	168.0	190	2.4	71	63B 4
7.6	179.6	203	2.3	71	63B 4
7.1	193.6	219	2.1	71	63B 4
6.8	200.1	226	1.1	63	63B 4
6.5	209.4	236	1.9	71	63B 4
6.2	220.8	249	1.8	71	63B 4
5.6	243.3	275	0.9	63	63B 4
5.4	253.4	286	1.6	71	63B 4
4.9	280.4	317	0.8	63	63B 4
4.8	286.0	323	1.4	71	63B 4
4.6	298.8	337	1.4	71	63B 4
4.0	342.9	387	1.2	71	63B 4
3.5	387.0	437	1.1	71	63B 4
3.0	294.9	524	2.0	90	71A 6
2.9	298.8	531	1.0	71	71A 6
2.8	309.6	551	1.9	90	71A 6
2.6	338.1	601	1.7	90	71A 6
2.5	342.9	610	0.9	71	71A 6
2.2	390.0	694	1.5	90	71A 6

0.22 kW	$n_1 = 1400 \text{ min}^{-1}$	63C 4
----------------	-------------------------------	-------

122	11.5	15	12.3	63	63C 4
105	13.3	18	12.3	63	63C 4
94	14.8	20	11.0	63	63C 4
82	17.2	23	9.5	63	63C 4
72	19.5	26	8.7	63	63C 4
59	23.7	32	7.5	63	63C 4
51	27.5	37	6.5	63	63C 4
45	31.2	42	5.7	63	63C 4
39	35.8	48	5.2	63	63C 4
31	44.6	60	4.2	63	63C 4
27	52.4	71	3.5	63	63C 4
20	69.0	93	2.7	63	63C 4
17.6	79.5	107	2.3	63	63C 4
15.4	90.6	122	1.9	63	63C 4

1.7 Leistungen der Getriebemotoren

n_2 min ⁻¹	ir	T2 Nm	FS'	OM-OC	
----------------------------	----	----------	-----	-------	--

0.22 kW	$n_1 = 1400 \text{ min}^{-1}$	63C 4
----------------	-------------------------------	-------

13.5	103.8	140	1.7	63	63C 4
11.3	123.5	167	2.8	71	63C 4
10.8	129.3	175	1.4	63	63C 4
9.8	143.1	193	2.4	71	63C 4
9.2	151.9	205	1.2	63	63C 4
9.0	154.8	209	2.2	71	63C 4
8.3	168.0	227	2.0	71	63C 4
7.8	179.6	243	1.9	71	63C 4
7.2	193.6	262	1.8	71	63C 4
7.0	200.1	270	0.9	63	63C 4
6.7	209.4	283	1.6	71	63C 4
6.3	220.8	298	1.5	71	63C 4
5.5	253.4	343	1.3	71	63C 4
4.9	286.0	386	1.2	71	63C 4
4.7	298.8	404	1.1	71	63C 4
4.1	342.9	463	1.0	71	63C 4
3.6	387.0	523	0.9	71	63C 4

0.25 kW	$n_1 = 1370 \text{ min}^{-1}$ $n_1 = 870 \text{ min}^{-1}$	71A 4 71B 6
----------------	---	----------------

173	7.9	12	13.7	63	71A 4
133	10.3	16	11.5	63	71A 4
119	11.5	18	10.6	63	71A 4
103	13.3	21	10.6	63	71A 4
92	14.8	23	9.5	63	71A 4
80	17.2	27	8.2	63	71A 4
70	19.5	31	7.5	63	71A 4
58	23.7	37	6.4	63	71A 4
50	27.5	43	5.6	63	71A 4
44	31.2	49	4.9	63	71A 4
38	35.8	56	4.5	63	71A 4
31	44.6	70	3.6	63	71A 4
26	52.4	82	3.0	63	71A 4
19.9	69.0	108	2.3	63	71A 4
17.2	79.5	125	2.0	63	71A 4
15.7	87.4	137	3.4	71	71A 4
15.1	90.6	142	1.6	63	71A 4
13.9	98.6	155	3.0	71	71A 4
13.2	103.8	163	1.4	63	71A 4
12.7	107.6	169	2.7	71	71A 4
11.1	123.5	194	2.4	71	71A 4
10.6	129.3	203	1.2	63	71A 4
9.0	151.9	238	1.0	63	71A 4
8.9	154.8	243	1.9	71	71A 4
8.2	168.0	263	1.7	71	71A 4
7.6	179.6	282	1.6	71	71A 4
6.5	209.4	328	1.4	71	71A 4
6.4	212.6	333	2.7	90	71A 4
6.2	220.8	346	1.3	71	71A 4
5.9	234.1	367	2.5	90	71A 4
5.4	253.4	397	1.2	71	71A 4
5.1	268.3	421	2.2	90	71A 4
4.8	286.0	449	1.0	71	71A 4
4.6	294.9	463	2.0	90	71A 4
4.6	298.8	469	1.0	71	71A 4
4.4	309.6	486	1.9	90	71A 4



1.7 Prestazioni motoriduttori

1.7 Gearmotors performances

1.7 Leistungen der Getriebemotoren

n_2 min ⁻¹	ir	T2 Nm	FS'	OM-OC	
----------------------------	----	----------	-----	-------	--

0.25 kW	$n_1 = 1370 \text{ min}^{-1}$	71A 4
	$n_1 = 870 \text{ min}^{-1}$	71B 6

4.1	338.1	530	1.7	90	71A 4
4.0	342.9	538	0.9	71	71A 4
3.5	390.0	612	1.5	90	71A 4
3.4	253.4	626	0.8	71	71B 6
3.0	294.9	728	1.4	90	71B 6
2.8	309.6	765	1.4	90	71B 6
2.6	338.1	835	1.2	90	71B 6
2.2	390.0	963	1.1	90	71B 6

0.37 kW	$n_1 = 2790 \text{ min}^{-1}$	63C 2
	$n_1 = 1380 \text{ min}^{-1}$	71B 4
	$n_1 = 910 \text{ min}^{-1}$	80A 6
	$n_1 = 880 \text{ min}^{-1}$	71C 6

271	10.3	12	12.8	63	63C 2
243	11.5	13	11.9	63	63C 2
210	13.3	15	11.6	63	63C 2
188	14.8	17	10.6	63	63C 2
174	7.9	18	9.3	63	71B 4
163	17.2	20	9.5	63	63C 2
143	19.5	22	8.5	63	63C 2
134	10.3	24	7.8	63	71B 4
120	11.5	26	7.2	63	71B 4
104	13.3	31	7.2	63	71B 4
93	14.8	34	6.4	63	71B 4
80	17.2	40	5.6	63	71B 4
71	19.5	45	5.1	63	71B 4
58	23.7	55	4.4	63	71B 4
50	27.5	63	3.8	63	71B 4
44	31.2	72	3.3	63	71B 4
39	35.8	82	3.0	63	71B 4
31	44.6	103	2.4	63	71B 4
26	52.4	121	2.1	63	71B 4
20	69.0	159	1.6	63	71B 4
19	73.2	178	3.1	80	71 B4
18.1	76.1	175	2.6	71	71B 4
17.4	79.5	183	1.4	63	71B 4
15.8	87.4	201	2.3	71	71B 4
15.2	90.6	209	1.1	63	71B 4
14.0	98.6	227	2.0	71	71B 4
13.3	103.8	239	1.0	63	71B 4
12.8	107.6	248	1.9	71	71B 4
11.3	122.3	282	3.2	90	71B 4
11.2	123.5	285	1.6	71	71B 4
10.7	129.3	298	0.8	63	71B 4
10.1	87.4	316	1.7	71	71C 6
8.9	154.8	357	1.3	71	71B 4
8.4	165.2	381	2.4	90	71B 4
8.2	168.0	387	1.2	71	71B 4
7.7	179.6	414	1.1	71	71B 4
7.1	193.6	446	1.0	71	71B 4
6.6	209.4	483	1.0	71	71B 4
6.5	212.6	490	1.9	90	71B 4
6.2	220.8	509	0.9	71	71B 4
5.9	234.1	539	1.7	90	71B 4
5.4	253.4	584	0.8	71	71B 4
5.1	268.3	618	1.5	90	71B 4
4.9	179.6	649	0.8	71	71C 6
4.7	294.9	680	1.3	90	71B 4

n_2 min ⁻¹	ir	T2 Nm	FS'	OM-OC	
----------------------------	----	----------	-----	-------	--

0.37 kW	$n_1 = 2790 \text{ min}^{-1}$	63C 2
	$n_1 = 1380 \text{ min}^{-1}$	71B 4
	$n_1 = 910 \text{ min}^{-1}$	80A 6
	$n_1 = 880 \text{ min}^{-1}$	71C 6

4.5	309.6	713	1.3	90	71B 4
4.1	338.1	779	1.2	90	71B 4
4.1	223.5	781	2.4	112	80A 6
3.7	247.9	866	2.2	112	80A 6
3.5	390.0	899	1.0	90	71B 4
2.8	309.6	1119	0.9	90	71C 6
2.4	375.3	1311	1.3	112	80A 6

0.55 kW	$n_1 = 2800 \text{ min}^{-1}$	71B 2
	$n_1 = 1380 \text{ min}^{-1}$	71C 4
	$n_1 = 1390 \text{ min}^{-1}$	80A 4
	$n_1 = 910 \text{ min}^{-1}$	80B 6

354	7.9	13	10.5	63	71B 2
272	10.3	17	8.6	63	71B 2
244	11.5	19	8.0	63	71B 2
211	13.3	22	7.8	63	71B 2
174	7.9	27	6.3	63	71C 4
134	10.3	35	5.3	63	71C 4
120	11.5	39	4.8	63	71C 4
104	13.3	46	4.8	63	71C 4
93	14.8	51	4.3	63	71C 4
80	17.2	59	3.7	63	71C 4
71	19.5	67	3.4	63	71C 4
58	23.7	81	3.0	63	71C 4
50	27.5	94	2.6	63	71C 4
44	31.2	107	2.2	63	71C 4
39	35.8	123	2.0	63	71C 4
32	42.6	146	3.2	71	71C 4
31	44.6	153	1.6	63	71C 4
28	49.3	169	2.7	71	71C 4
27	51.0	185	3.0	80	71 C4
26	52.4	179	1.4	63	71C 4
26	53.4	183	2.5	71	71C 4
24	57.0	206	2.4	80	71 C4
24	57.9	198	2.3	71	71C 4
20	69.0	236	1.1	63	71C 4
18,9	73,2	265	2,1	80	71 C4
18.1	76.1	261	1.8	71	71C 4
17.4	79.5	272	0.9	63	71C 4
15.8	87.4	299	1.5	71	71C 4
14.9	92.5	317	2.9	90	71C 4
14.0	98.6	338	1.4	71	71C 4
12.9	106.7	366	2.5	90	71C 4
12.8	107.6	369	1.2	71	71C 4
11.3	122.3	419	2.2	90	71C 4
11.2	123.5	423	1.1	71	71C 4
10.5	131.1	449	2.0	90	71C 4
9.6	143.1	490	0.9	71	71C 4
9.1	151.9	520	1.7	90	71C 4
8.9	154.8	530	0.9	71	71C 4
8.4	166.0	565	3.1	112	80A 4
8.4	165.2	566	1.6	90	71C 4
8.2	168.0	575	0.8	71	71C 4
7.1	194.9	663	2.6	112	80A 4
6.5	212.6	728	1.2	90	71C 4
6.2	223.5	760	2.3	112	80A 4
5.9	234.1	802	1.1	90	71C 4
5.1	268.3	919	1.0	90	71C 4

n_2 min ⁻¹	ir	T2 Nm	FS'	OM-OC	
----------------------------	----	----------	-----	-------	--

0.55 kW	$n_1 = 2800 \text{ min}^{-1}$	71B 2
	$n_1 = 1380 \text{ min}^{-1}$	71C 4
	$n_1 = 1390 \text{ min}^{-1}$	80A 4
	$n_1 = 910 \text{ min}^{-1}$	80B 6

5.1	272.4	926	1.9	112	80A 4
5.1	271.4	950	2.8	125	71C 4
4.7	298.1	1014	1.7	112	80A 4
4.5	309.6	1060	0.9	90	71C 4
4.1	342.9	1166	1.5	112	80A 4
3.7	375.3	1276	1.4	112	80A 4

0.75 kW	$n_1 = 2800 \text{ min}^{-1}$	71C 2
	$n_1 = 1390 \text{ min}^{-1}$	80B 4
	$n_1 = 910 \text{ min}^{-1}$	80C 6

354	7.9	18	7.7	63	71C 2
272	10.3	24	6.3	63	71C 2
244	11.5	26	5.9	63	71C 2
211	13.3	31	5.7	63	71C 2
176	7.9	37	4.6	63	80B 4
135	10.3	48	3.9	63	80B 4
121	11.5	53	3.6	63	80B 4
105	13.3	61	3.6	63	80B 4
94	14.8	69	3.2	63	80B 4
81	17.2	80	2.8	63	80B 4
71	19.5	91	2.5	63	80B 4
59	23.7	110	2.2	63	80B 4
51	27.5	127	1.9	63	80B 4
45	30.6	142	3.2	71	80B 4
44	31.2	145	1.7	63	80B 4
39	35.8	166	1.5	63	80B 4
37	37.1	172	2.7	71	80B 4
35	39.8	195	2.8	80	80 B4
33	42.6	197	2.3	71	80B 4
31	44.6	207	1.2	63	80B 4
28	49.3	229	2.0	71	80B 4
27	51.0	250	2.2	80	80 B4
27	52.4	243	1.0	63	80B 4
26	53.4	247	1.9	71	80B 4
24	57.0	279	1.8	80	80 B4
23	59.5	276	3.3	90	80B 4
20	69.0	320	0.8	63	80B 4
19,0	73,2	358	2,8	100	80 B4
19,0	73,2	358	1,5	80	80 B4
19,0	73,3	340	2,7	90	80B 4
18,3	76,1	353	1,3	71	80B 4
17,2	80,7	374	2,4	90	80B 4
15,9	87,4	405	1,1	71	80B 4
15,0	92,5	429	2,1	90	80B 4
14,1	98,6	457	1,0	71	80B 4
13,0	106,7	495	1,8	90	80B 4
12,9	107,6	499	0,9	71	80B 4
11,4	122,3	567	1,6	90	80B 4
11,3	123,5	573	0,8	71	80B 4
10,6	131,1	608	1,5	90	80B 4
10,2	135,6	629	2,8	112	80B 4
9,2	151,9	704	1,3	90	80B 4
9,0	154,8	718	2,4	112	80B 4
8,4	165,2	766	1,2	90	80B 4
8,4	166,0	770	2,3	112	80B 4
7,1	194,9	904	1,9	112	80B 4
6,5	212,6	986	0,9	90	80B 4



1.7 Prestazioni motoriduttori

1.7 Gearmotors performances

1.7 Leistungen der Getriebemotoren

n_2 min ⁻¹	ir	T2 Nm	FS'	OM-OC	
----------------------------	----	----------	-----	-------	--

0.75 kW	$n_1= 2800 \text{ min}^{-1}$ $n_1= 1390 \text{ min}^{-1}$ $n_1= 910 \text{ min}^{-1}$	71C 2 80B 4 80C 6
----------------	---	-------------------------

6.2	223.5	1036	1.7	112	80B 4
5.9	234.1	1086	0.8	90	80B 4
5.6	247.9	1149	1.5	112	80B 4
5.1	272.4	1263	1.4	112	80B 4
4.7	298.1	1383	1.3	112	80B 4
4.1	342.9	1590	1.1	112	80B 4
3.7	375.3	1740	1.0	112	80B 4

0.88 kW	$n_1= 1350 \text{ min}^{-1}$	80C 4
----------------	------------------------------	-------

171	7.9	44	3.8	63	80C 4
131	10.3	58	3.2	63	80C 4
118	11.5	64	3.0	63	80C 4
102	13.3	74	3.0	63	80C 4
91	14.8	83	2.6	63	80C 4
79	17.2	96	2.3	63	80C 4
69	19.5	109	2.1	63	80C 4
59	22.9	128	3.3	71	80C 4
57	23.7	133	1.8	63	80C 4
50	27.1	152	3.0	71	80C 4
49	27.5	154	1.6	63	80C 4
44	31.0	183	3.0	80	80 C4
38	35.8	200	1.2	63	80C 4
36	37.1	208	2.2	71	80C 4
34	39.8	235	2.3	80	80 C4
32	42.6	238	1.9	71	80C 4
30	44.6	250	1.0	63	80C 4
27	49.3	276	1.7	71	80C 4
26	51.0	302	1.8	80	80 C4
26	52.4	293	3.1	90	80C 4
26	52.4	293	0.9	63	80C 4
24	57.0	337	1.5	80	80 C4
23	57.9	324	1.4	71	80C 4
23	58.0	343	2.9	100	80 C4
23	59.5	333	2.7	90	80C 4
18,4	73,2	433	2,3	100	80 C4
18,4	73,2	433	1,3	80	80 C4
18,4	73,3	411	2,2	90	80C 4
17,7	76,1	427	1,1	71	80C 4
16,7	80,7	452	2,0	90	80C 4
15,5	87,4	489	0,9	71	80C 4
14,6	92,5	518	1,8	90	80C 4
14,4	93,9	526	3,3	112	80C 4
12,7	106,7	598	1,5	90	80C 4
12,2	110,9	621	2,8	112	80C 4
10,3	131,1	735	1,2	90	80C 4
10,0	135,6	760	2,3	112	80C 4
8,9	151,9	851	1,1	90	80C 4
8,7	154,8	868	2,0	112	80C 4
8,2	165,2	896	1,0	90	80C 4
8,1	166,0	830	1,9	112	80C 4
6,9	194,9	1092	1,6	112	80C 4
6,0	223,5	1252	1,4	112	80C 4
5,0	272,4	1526	1,1	112	80C 4
3,9	342,9	1921	0,9	112	80C 4

n_2 min ⁻¹	ir	T2 Nm	FS'	OM-OC	
----------------------------	----	----------	-----	-------	--

1.1 kW	$n_1= 2830 \text{ min}^{-1}$ $n_1= 1390 \text{ min}^{-1}$ $n_1= 920 \text{ min}^{-1}$	80B 2 80D 4 90L 6
---------------	---	-------------------------

549	5,2	18	15,6	80	80 B2
358	7,9	26	5,3	63	80B 2
275	10,3	34	4,4	63	80B 2
247	11,5	38	4	63	80B 2
213	13,3	44	3,9	63	80B 2
191	14,8	50	3,6	63	80B 2
176	7,9	54	3,2	63	80D 4
165	17,2	57	3,2	63	80B 2
145	19,5	65	2,9	63	80B 2
135	10,3	70	2,6	63	80D 4
121	11,5	78	2,4	63	80D 4
105	13,3	90	2,4	63	80D 4
94	14,8	101	2,2	63	80D 4
81	17,2	117	1,9	63	80D 4
74	18,7	127	3,2	71	80D 4
71	19,5	133	1,7	63	80D 4
61	22,9	156	2,8	71	80D 4
59	23,7	161	1,5	63	80D 4
51	27,5	187	1,3	63	80D 4
51	27,1	184	2,5	71	80D 4
45	30,6	208	2,2	71	80D 4
45	31,0	223	2,5	80	80 D4
44	31,2	213	1,1	63	80D 4
39	35,8	243	1	63	80D 4
39	73,2	258	2,0	80	80 B2
37	37,1	252	1,8	71	80D 4
35	39,8	286	1,9	80	80 D4
33	42,6	290	1,6	71	80D 4
33	42,2	287	3,2	90	80D 4
31	44,6	303	0,8	63	80D 4
28	49,3	336	1,4	71	80D 4
27	51,0	367	1,5	80	80 D4
27	52,4	356	2,6	90	80D 4
26	53,4	363	1,3	71	80D 4
24	57,0	409	1,2	80	80 D4
24	57,9	394	1,2	71	80D 4
24	58,0	417	2,4	100	80 D4
23	59,5	404	2,3	90	80D 4
19,0	73,3	498	1,8	90	80D 4
19,0	73,2	526	1,9	100	80 D4
19,0	73,2	526	1,0	80	80 D4
18,3	76,1	518	0,9	71	80D 4
18,0	51,0	554	2,1	100	90 L6
18,0	51,0	554	1,0	80	90 L6
18,0	77	524	3,3	112	80D 4
17,2	80,7	549	1,7	90	80D 4
16,3	85,4	581	3	112	80D 4
16,1	57,0	619	0,8	80	90 L6
15,9	87,4	594	0,8	71	80D 4
15,9	58,0	629	1,6	100	90 L6
14,8	93,9	639	2,7	112	80D 4
14,7	94,4	642	1,4	90	80D 4
13,5	102,8	699	2,5	112	80D 4
13,0	106,7	726	1,3	90	80D 4
12,6	73,2	794	1,3	100	90 L6
12,5	110,9	754	2,3	112	80D 4
12,2	75,4	818	2,5	125	90 L6
11,4	122,3	832	1,1	90	80D 4
11,1	125,2	852	2,1	112	80D 4

n_2 min ⁻¹	ir	T2 Nm	FS'	OM-OC	
----------------------------	----	----------	-----	-------	--

1.1 kW	$n_1= 2830 \text{ min}^{-1}$ $n_1= 1390 \text{ min}^{-1}$ $n_1= 920 \text{ min}^{-1}$	80B 2 80D 4 90L 6
---------------	---	-------------------------

10,6	131,1	892	1	90	80D 4
10,2	135,6	923	1,9	112	80D 4
9,2	151,9	1033	0,9	90	80D 4
9,0	154,8	1053	1,7	112	80D 4
8,4	109,4	1174	3,0	132	90 L6
8,4	166	1129	1,5	112	80D 4
8,4	165,2	1124	0,8	90	80D 4
7,3	125,5	1347	2,6	132	90 L6
7,1	194,9	1326	1,3	112	80D 4
6,7	136,7	1467	2,4	132	90 L6
6,2	223,5	1520	1,2	112	80D 4
6,2	149,5	1605	2,2	132	90 L6
5,6	247,9	1686	1	112	80D 4
5,6	164,6	1766	2,0	132	90 L6
5,1	180,0	1932	1,8	132	90 L6
5,1	272,4	1853	0,9	112	80D 4
4,7	298,1	2028	0,9	112	80D 4



1.7 Prestazioni motoriduttori

1.7 Gearmotors performances

1.7 Leistungen der Getriebemotoren

n_2 min ⁻¹	ir	T2 Nm	FS'	OM-OC	
----------------------------	----	----------	-----	-------	---

2.2 kW	$n_1=2840 \text{ min}^{-1}$	90L 2
	$n_1=1410 \text{ min}^{-1}$	100A 4
	$n_1=940 \text{ min}^{-1}$	100BL 6

551	5.2	36	7.8	80	90L 2
414	6.9	46	4.8	71	90L 2
359	7.9	53	2.7	63	90L 2
338	8.4	56	4.5	71	90L 2
286	9.9	66	3.9	71	90L 2
276	10.3	68	2.2	63	90L 2
250	11.4	76	3.7	71	90L 2
248	11.5	76	2	63	90L 2
214	13.3	88	2	63	90L 2
206	6.9	92	2.9	71	100A 4
192	14.8	99	1.8	63	90L 2
182	5.2	109	2.9	80	100BL 6
178	7.9	106	1.6	63	100A 4
168	8.4	113	2.7	71	100A 4
142	9.9	133	2.4	71	100A 4
137	10.3	138	1.3	63	100A 4
132	7.1	151	2.6	80	100BL 6
124	11.4	153	2.2	71	100A 4
123	11.5	154	1.2	63	100A 4
109	13	174	3.1	90	100A 4
106	13.3	178	1.2	63	100A 4
101	14	188	3.1	90	100A 4
101	13.9	187	2.1	71	100A 4
96	14.6	207	2.9	80	100A 4
95	14.8	199	1.1	63	100A 4
86	16.5	221	1.8	71	100A 4
85	16.7	236	2.5	80	100A 4
82	17.2	230	1	63	100A 4
79	17.7	238	3.2	90	100A 4
75	18.7	251	1.6	71	100A 4
72	19.5	262	0.9	63	100A 4
70	20.1	270	2.9	90	100A 4
66	21.2	300	2.0	80	100A 4
61	23	308	2.7	90	100A 4
61	22.9	308	1.4	71	100A 4
58	24.2	342	1.8	80	100A 4
55	25.7	344	2.6	90	100A 4
52	27.1	363	1.3	71	100A 4
49	28.8	387	2.4	90	100A 4
46	30.6	410	1.1	71	100A 4
45	31.0	439	2.5	100	100A 4
45	31.0	439	1.3	80	100A 4
43	32.5	436	2.1	90	100A 4
38	36.9	495	1.8	90	100A 4
38	37.1	497	0.9	71	100A 4
35	39.8	563	1.0	80	100A 4
35	40.5	573	1.8	100	100A 4
33	42.2	565	1.6	90	100A 4
33	42.6	571	0.8	71	100A 4
31	45.2	606	1.5	90	100A 4
30	46.8	627	2.8	112	100A 4
28	51.0	723	1.6	100	100A 4
28	51.0	723	0.8	80	100A 4
27	52.4	702	1.3	90	100A 4
27	52.6	744	3.1	125	100A 4
26	53.4	716	2.4	112	100A 4
25	57.2	768	2.3	112	100A 4
24	58.0	821	2.4	125	100A 4
24	58.0	821	1.2	100	100A 4

n_2 min ⁻¹	ir	T2 Nm	FS'	OM-OC	
----------------------------	----	----------	-----	-------	--

2.2 kW	$n_1=2840 \text{ min}^{-1}$	90L 2
	$n_1=1410 \text{ min}^{-1}$	100A 4
	$n_1=940 \text{ min}^{-1}$	100BL 6

24	59.5	797	1.1	90	100A 4
22	64.6	866	2	112	100A 4
19.3	73.2	1036	1.0	100	100A 4
19.2	73.3	983	0.9	90	100A 4
18.7	75.4	1067	1.9	125	100A 4
18.5	76.3	1068	3.3	132	100A 4
18.4	51.0	1084	1.1	100	100BL 6
18.3	77	1033	1.7	112	100A 4
17.9	52.6	1116	2.1	125	100BL 6
17.5	80.7	1082	0.8	90	100A 4
17.0	83.0	1163	3.0	132	100A 4
16.5	85.4	1146	1.5	112	100A 4
16.2	58.0	1232	1.6	125	100BL 6
16.2	58.0	1232	0.8	100	100BL 6
15.5	90.8	1272	2.8	132	100A 4
15	93.9	1259	1.4	112	100A 4
14.2	99.4	1392	2.5	132	100A 4
13.7	102.8	1378	1.3	112	100A 4
13.0	72.3	1536	2.6	140	100BL 6
12.9	109.4	1532	2.3	132	100A 4
12.8	109.8	1538	3.3	150	100A 4
12.7	110.9	1487	1.2	112	100A 4
12.5	75.4	1601	1.3	125	100BL 6
11.9	78.7	1653	3.1	150	100BL 6
11.3	125.2	1679	1	112	100A 4
11.2	125.5	1758	2.0	132	100A 4
10.9	129.5	1813	2.8	150	100A 4
10.4	135.6	1819	1	112	100A 4
10.3	136.7	1914	1.8	132	100A 4
10.0	141.6	1983	2.5	150	100A 4
9.4	149.5	2094	1.7	132	100A 4
9.2	101.7	2137	2.4	150	100BL 6
9.1	154.8	2076	0.8	112	100A 4
9.1	155.7	2181	2.3	150	100A 4
8.7	162.7	2279	3.3	170	100A 4
8.6	164.6	2305	1.5	132	100A 4
8.5	166	2227	0.8	112	100A 4
7.9	178.1	2494	2.8	170	100A 4
7.8	180.0	2522	1.4	132	100A 4
7.6	185.5	2599	1.8	150	100A 4
7.6	124.1	2607	2.9	170	100BL 6
7.2	196.0	2745	2.4	170	100A 4
6.9	204.2	2860	1.6	150	100A 4
6.9	136.7	2871	1.2	132	100BL 6
6.6	141.6	2974	1.7	150	100BL 6
6.3	149.4	3139	2.4	170	100BL 6
6.3	149.5	3141	1.1	132	100BL 6
6.0	155.7	3271	1.6	150	100BL 6
5.8	162.7	3419	2.2	170	100BL 6
5.7	164.6	3458	1.0	132	100BL 6
5.3	178.1	3741	1.9	170	100BL 6
5.2	180.0	3783	0.9	132	100BL 6
5.1	185.5	3898	1.2	150	100BL 6
4.8	196.0	4117	1.6	170	100BL 6
4.6	204.2	4290	1.1	150	100BL 6

n_2 min ⁻¹	ir	T2 Nm	FS'	OM-OC	
----------------------------	----	----------	-----	-------	---

3 kW	$n_1=2840 \text{ min}^{-1}$	90LB 2
	$n_1=1420 \text{ min}^{-1}$	100B 4
	$n_1=940 \text{ min}^{-1}$	112B 6

551	5.2	49.4	5.8	80	90LB 2
414	6.9	62	3.5	71	90LB 2
359	7.9	72	1.9	63*	90LB 2
338	8.4	76	3.3	71	90LB 2
286	9.9	90	2.9	71	90LB 2
276	10.3	93	1.6	63*	90LB 2
276	5.2	99	3.1	80	100B 4
250	11.4	103	2.7	71	90LB 2
248	11.5	104	1.5	63*	90LB 2
214	13.3	121	1.5	63*	90LB 2
207	6.9	125	2.2	71	100B 4
200	7.1	136	2.8	80	100B 4
197	7.2	131	3.3	90	100B 4
192	14.8	135	1.3	63*	90LB 2
180	7.9	144	1.2	63*	100B 4
169	8.4	153	2	71	100B 4
157	9	164	2.7	90	100B 4
143	9.9	180	1.8	71	100B 4
142	10.0	191	2.6	80	100B 4
140	10.1	184	2.7	90	100B 4
138	10.3	187	1	63*	100B 4
125	11.4	207	1.6	71	100B 4
124	11.5	208	2.5	90	100B 4
124	11.5	208	0.9	63*	100B 4
119	11.9	229	2.4	80	100B 4
109	13	236	2.3	90	100B 4
107	13.3	241	0.9	63*	100B 4
102	13.9	253	1.6	71	100B 4
101	14	254	2.3	90	100B 4
97	14.6	281	2.1	80	100B 4
96	14.8	269	0.8	63*	100B 4
90	15.7	285	2.5	90	100B 4
86	16.5	299	1.3	71	100B 4
85	16.7	320	1.9	80	100B 4
80	17.7	322	2.3	90	100B 4
76	18.7	340	1.2	71	100B 4
71	20.1	366	2.2	90	100B 4
68	20.9	380	3.4	112	100B 4
67	21.2	407	2.8	100	100B 4
67	21.2	407	1.5	80	100B 4
62	23	418	2	90	100B 4
62	22.9	416	1	71	100B 4
60	23.6	429	3.1	112	100B 4
59	24.2	463	1.3	80	100B 4
58	24.6	471	2.5	100	100B 4
55	25.6	465	3	112	100B 4
55	25.7	466	1.9	90	100B 4
52	27.1	492	0.9	71	100B 4
49	28.8	524	1.7	90	100B 4
48	29.4	534	3.3	112	100B 4
46	30.6	555	0.8	71	100B 4
46	31.0	595	1.9	100	100B 4
46	31.0	595	0.9	80	100B 4
44	32.5	591	1.5	90	100B 4
43	32.8	595	2.9	112	100B 4
37	38.2	694	2.5	112	100B 4
35	40.5	775	2.6	125	100B 4
35	40.5	775	1.4	100	100B 4



1.7 Prestazioni motoriduttori

1.7 Gearmotors performances

1.7 Leistungen der Getriebemotoren

n_2 min ⁻¹	ir	T2 Nm	FS'	OM-OC	
3 kW					
$n_1 = 2840 \text{ min}^{-1}$ $n_1 = 1420 \text{ min}^{-1}$ $n_1 = 940 \text{ min}^{-1}$					
					90LB 2
					100B 4
					112B 6

n_2 min ⁻¹	ir	T2 Nm	FS'	OM-OC	
3 kW					
$n_1 = 2840 \text{ min}^{-1}$ $n_1 = 1420 \text{ min}^{-1}$ $n_1 = 940 \text{ min}^{-1}$					
					90LB 2
					100B 4
					112B 6

n_2 min ⁻¹	ir	T2 Nm	FS'	OM-OC	
4 kW					
$n_1 = 2860 \text{ min}^{-1}$ $n_1 = 1410 \text{ min}^{-1}$					
					100B 2
					100BL 4

34	42.2	766	1.2	90	100B 4
33	43.2	784	2.2	112	100B 4
31	45.2	821	1.1	90	100B 4
30	46.8	849	2.1	112	100B 4
28	51.0	978	1.2	100	100B 4
27	52.6	1008	2.3	125	100B 4
27	53.4	969	1.8	112	100B 4
27	52.4	951	1	90	100B 4
25	57.2	1039	1.7	112	100B 4
25	57.3	1087	3.2	132	100B 4
24	58.0	1112	1.8	125	100B 4
24	58.0	1112	0.9	100	100B 4
24	59.5	1080	0.8	90	100B 4
22	64.6	1172	1.5	112	100B 4
22	65.1	1235	2.8	132	100B 4
20	72.3	1386	2.9	140	100B 4
18.8	75.4	1445	1.4	125	100B 4
18.6	76.3	1446	2.4	132	100B 4
18.4	51.0	1478	0.8	100	112B 6
18.4	77	1399	1.3	112	100B 4
18.3	51.3	1485	3.1	140	112B 6
18.0	78.7	1492	3.4	150	100B 4
17.9	52.6	1522	1.5	125	112B 6
17.1	83.0	1575	2.2	132	100B 4
16.6	85.4	1551	1.1	112	100B 4
16.5	86.0	1632	3.1	150	100B 4
16.4	57.4	1662	2.6	140	112B 6
16.2	58.0	1680	1.2	125	112B 6
15.6	90.8	1723	2.0	132	100B 4
15.1	93.9	1705	1	112	100B 4
15.0	94.6	1794	2.8	150	100B 4
14.3	99.4	1885	1.9	132	100B 4
14.0	101.7	1929	2.6	150	100B 4
13.8	102.8	1866	0.9	112	100B 4
13.0	72.3	2094	1.9	140	112B 6
13.0	109.4	2075	1.7	132	100B 4
12.9	109.8	2082	2.4	150	100B 4
12.8	110.9	2014	0.9	112	100B 4
12.5	75.4	2183	0.9	125	112B 6
11.4	124.1	2353	3.2	170	100B 4
11.3	125.5	2381	1.5	132	100B 4
11.0	129.5	2455	2.0	150	100B 4
10.5	135.8	2575	2.9	170	100B 4
10.4	136.7	2592	1.4	132	100B 4
10.0	141.6	2685	1.9	150	100B 4
9.5	149.4	2834	2.6	170	100B 4
9.5	149.5	2835	1.2	132	100B 4
9.1	155.7	2953	1.7	150	100B 4
8.7	162.7	3086	2.4	170	100B 4
8.6	164.6	3121	1.1	132	100B 4
8.0	178.1	3377	2.0	170	100B 4
7.9	180.0	3415	1.0	132	100B 4
7.7	185.5	3519	1.4	150	100B 4
7.2	196.0	3716	1.8	170	100B 4
7.0	204.2	3873	1.2	150	100B 4
6.9	135.8	3890	2.0	170	112B 6
6.9	136.7	3915	0.9	132	112B 6
6.6	141.6	4056	1.3	150	112B 6

6.3	149.4	4281	1.8	170	112B 6
6.3	149.5	4283	0.8	132	112B 6
6.0	155.7	4461	1.1	150	112B 6
5.8	162.7	4662	1.6	170	112B 6
5.7	164.6	4715	0.8	132	112B 6
5.3	178.1	5101	1.4	170	112B 6
5.1	185.5	5316	0.9	150	112B 6
4.8	196.0	5614	1.2	170	112B 6
4.6	204.2	5850	0.8	150	112B 6

4 kW					
$n_1 = 2860 \text{ min}^{-1}$ $n_1 = 1410 \text{ min}^{-1}$					
					100B 2
					100BL 4

555	5.2	65	4.3	80	100 B2
417	6.9	82	2.7	71*	100B 2
362	7.9	95	1.5	63*	100B 2
340	8.4	101	2.5	71*	100B 2
317	9	109	3.2	90	100B 2
288	9.9	119	2.2	71*	100B 2
282	10.1	122	2.9	90	100B 2
278	10.3	124	1.2	63*	100B 2
274	5.2	133	2.3	80	100 BL4
251	11.4	137	2	71*	100B 2
249	11.5	138	1.1	63*	100B 2
220	13	156	2.6	90	100B 2
206	6.9	167	1.6	71*	100BL 4
198	7.1	183	2.1	80	100 BL4
195	7.2	176	2.4	90	100BL 4
178	7.9	193	0.9	63*	100BL 4
172	16.7	212	2.6	80	100 B2
168	8.4	205	1.5	71*	100BL 4
159	8.9	217	3.3	112	100BL 4
156	9	220	2	90	100BL 4
142	9.9	242	1.3	71*	100BL 4
141	10.0	257	1.9	80	100 BL4
139	10.1	247	2	90	100BL 4
124	11.4	277	1.2	71*	100BL 4
123	11.5	279	1.9	90	100BL 4
120	11.8	287	3	112	100BL 4
118	11.9	307	1.8	80	100 BL4
109	13	317	1.7	90	100BL 4
108	13.1	320	2.8	112	100BL 4
101	14	341	1.7	90	100BL 4
101	13.9	340	1.2	71*	100BL 4
96	14.6	377	3.1	100	100 BL4
96	14.6	377	1.6	80	100 BL4
90	15.7	383	1.9	90	100BL 4
88	16.1	393	3	112	100BL 4
86	16.5	401	1	71*	100BL 4
85	16.7	429	1.4	80	100 BL4
83	17.0	437	2.7	100	100 BL4
79	17.9	438	2.8	112	100BL 4
79	17.7	433	1.7	90	100BL 4
75	18.7	456	0.9	71*	100BL 4
70	20.1	491	1.6	90	100BL 4
67	20.9	510	2.5	112	100BL 4
66	21.2	546	2.1	100	100 BL4

66	21.2	546	1.1	80	100 BL4
63	22.3	543	3.2	112	100BL 4
61	23	561	1.5	90	100BL 4
60	23.6	576	2.3	112	100BL 4
58	24.2	622	1.0	80	100 BL4
57	24.6	633	1.9	100	100 BL4
55	25.6	624	2.2	112	100BL 4
55	25.7	626	1.4	90	100BL 4
49	28.8	703	1.3	90	100BL 4
48	29.4	717	2.4	112	100BL 4
45	31.0	798	1.4	100	100 BL4
44	31.9	822	2.7	125	100 BL4
43	32.8	800	2.2	112	100BL 4
43	32.5	793	1.1	90	100BL 4
38	36.9	900	1	90	100BL 4
37	38.2	932	1.9	112	100BL 4
35	40.5	1041	2.0	125	100 BL4
35	40.5	1041	1.0	100	100 BL4
34	41.7	1063	3.3	132	100BL 4
33	43.2	1053	1.7	112	100BL 4
33	42.2	1028	0.9	90	100BL 4
31	44.9	1144	3.1	132	100BL 4
31	45.2	1102	0.8	90	100BL 4
30	46.8	1140	1.5	112	100BL 4
28	51.0	1314	0.9	100	100 BL4
27	52.6	1353	1.7	125	100 BL4
27	52.6	1340	2.6	132	100BL 4
26	53.4	1301	1.3	112	100BL 4
25	57.3	1459	2.4	132	100BL 4
25	57.4	1477	2.8	140	100 BL4
24	58.0	1493	1.3	125	100 BL4
24	59.4	1512	3.3	150	100BL 4
22	64.6	1574	1.1	112	100BL 4
22	65.1	1659	2.1	132	100BL 4
21	66.7	1699	2.9	150	100BL 4
19	72.3	1861	2.1	140	100 BL4
19	75.4	1940	1.0	125	100 BL4
18.5	76.3	1942	1.8	132	100BL 4
18.3	77	1878	0.9	112	100BL 4
17.9	78.7	2003	2.5	150	100BL 4
17.0	83.0	2115	1.7	132	100BL 4
16.5	85.4	2083	0.8	112	100BL 4
16.4	86.0	2191	2.3	150	100BL 4
15.8	89.4	2277	3.3	170	100BL 4
15.5	90.8	2313	1.5	132	100BL 4
14.9	94.6	2409	2.1	150	100BL 4
14.3	98.4	2506	3.0	170	100BL 4
14.2	99.4	2532	1.4	132	100BL 4
13.9	101.7	2590	1.9	150	100BL 4
12.9	109.4	2786	1.3	132	100BL 4
12.8	109.8	2796	1.8	150	100BL 4
12.4	113.9	2901	2.6	170	100BL 4
11.4	124.1	3160	2.4	170	100BL 4
11.2	125.5	3197	1.1	132	100BL 4
10.9	129.5	3297	1.5	150	100BL 4
10.4	135.8	3457	2.2	170	100BL 4
10.3	136.7	3480	1.0	132	100BL 4
10.0	141.6	3605	1.4	150	100BL 4



1.7 Prestazioni motoriduttori

1.7 Gearmotors performances

1.7 Leistungen der Getriebemotoren

n_2 min ⁻¹	ir	T2 Nm	FS'	OM-OC	
----------------------------	----	----------	-----	-------	--

7.5 kW	$n_1=2860 \text{ min}^{-1}$ $n_1=1440 \text{ min}^{-1}$	112BL 2 132M 4
---------------	--	-------------------

98	14.6	692	1.7	100	132M4
92	15.7	704	1	90*	132M 4
90	16.0	747	2.3	132	132M 4
89	16.1	721	1.6	112	132M 4
85	17.0	802	2.9	125	132M4
85	17.0	802	1.5	100	132M4
81	17.7	794	0.9	90*	132M 4
80	17.9	839	2.1	132	132M 4
80	17.9	803	1.6	112	132M 4
72	20.1	901	0.9	90*	132M 4
71	20.3	947	2.1	132	132M 4
69	20.9	937	1.4	112	132M 4
68	21.2	1002	2.1	125	132M4
68	21.2	1002	1.1	100	132M4
67	21.7	1012	2.2	132	132M 4
65	22.3	996	1.8	112	132M 4
63	23	1029	0.8	90*	132M 4
61	23.6	1058	1.3	112	132M 4
59	24.3	1137	2.0	132	132M 4
59	24.6	1162	2.0	125	132M4
59	24.6	1162	1.0	100	132M4
56	25.6	1146	1.2	112	132M 4
56	25.7	1149	0.8	90*	132M 4
52	27.5	1283	2.1	132	132M 4
49	29.4	1317	1.3	112	132M 4
48	30.3	1416	3.5	150	132M 4
46	31.0	1466	0.8	100	132M4
46	31.2	1458	2.2	132	132M 4
45	31.9	1509	1.5	125	132M4
44	32.8	1468	1.2	112*	132M 4
43	33.4	1578	2.8	140	132M4
42	34.5	1613	3.1	150	132M 4
40	36.3	1697	2.1	132	132M 4
39	36.9	1726	2.9	150	132M 4
38	38.2	1711	1	112*	132M 4
36	40.5	1912	1.1	125	132M4
35	40.7	1924	2.1	140	132M4
35	41.7	1951	1.8	132	132M 4
34	42.6	1994	2.5	150	132M 4
33	43.2	1933	0.9	112	132M 4
32	44.9	2101	1.7	132	132M 4
32	45.6	2130	3.5	170	132M 4
31	46.0	2152	2.3	150	132M 4
29	49.8	2331	3.2	170	132M 4
28	51.3	2423	1.9	140	132M4
27	52.6	2484	0.9	125	132M4
27	52.6	2461	1.4	132	132M 4
27	54.3	2538	2.0	150	132M 4
27	54.3	2538	3.0	170	132M 4
25	57.3	2679	1.3	132	132M 4
25	57.4	2712	1.5	140	132M4
24	59.4	2775	1.8	150	132M 4
22	64.0	2994	3.5	190	132M 4
22	64.0	2994	2.5	170	132M 4
22	65.1	3045	1.1	132	132M 4
22	66.7	3119	1.6	150	132M 4
21	68.9	3222	3.3	190	132M 4
21	68.9	3222	2.3	170	132M 4

n_2 min ⁻¹	ir	T2 Nm	FS'	OM-OC	
----------------------------	----	----------	-----	-------	--

7.5 kW	$n_1=2860 \text{ min}^{-1}$ $n_1=1440 \text{ min}^{-1}$	112BL 2 132M 4
---------------	--	-------------------

20	72.3	3417	1.2	140	132M4
19.2	75.0	3508	2.1	170	132M 4
19.2	75.0	3508	3.0	190	132M 4
18.9	76.3	3566	1.0	132	132M 4
18.3	78.7	3678	1.4	150	132M 4
17.6	81.7	3821	2.7	190	132M 4
17.6	81.7	3821	2.0	170	132M 4
17.3	83.0	3882	0.9	132	132M 4
16.7	86.0	4022	1.2	150	132M 4
16.1	89.4	4181	2.5	190	132M 4
16.1	89.4	4181	1.8	170	132M 4
15.9	90.8	4247	0.8	132	132M 4
15.2	94.6	4423	1.1	150	132M 4
14.7	97.9	4575	2.3	190	132M 4
14.6	98.4	4601	1.6	170	132M 4
14.5	99.4	4648	0.8	132	132M 4
14.2	101.7	4755	1.1	150	132M 4
13.2	109.4	5115	0.7	132	132M 4
13.1	109.8	5134	1.0	150	132M 4
12.6	113.9	5327	2.0	190	132M 4
12.6	113.9	5327	1.4	170	132M 4
11.6	124.1	5801	1.3	170	132M 4
11.6	124.1	5801	1.8	190	132M 4
11.1	129.5	6053	0.8	150	132M 4
10.6	135.8	6348	1.7	190	132M 4
10.6	135.8	6348	1.2	170	132M 4
10.2	141.6	6619	0.8	150	132M 4
9.7	147.8	6913	1.5	190	132M 4
9.6	149.4	6986	1.1	170	132M 4
9.2	155.7	7280	0.7	150	132M 4
8.9	162.7	7607	1.4	190	132M 4
8.9	162.7	7607	1.0	170	132M 4
8.1	178.1	8325	1.2	190	132M 4
8.1	178.1	8325	0.8	170	132M 4
7.3	196.0	9162	1.1	190	132M 4
7.3	196.0	9162	0.7	170	132M 4

n_2 min ⁻¹	ir	T2 Nm	FS'	OM-OC	
----------------------------	----	----------	-----	-------	--

9.2 kW	$n_1=1450 \text{ min}^{-1}$	132ML 4
---------------	-----------------------------	---------

281	5.2	293	1.7	100	132ML4
201	7.2	393	1.1	90*	132ML 4
196	7.4	422	3.1	125	132ML4
196	7.4	422	1.8	100	132ML4
189	7.7	417	1.6	112	132ML 4
163	8.9	485	1.5	112	132ML 4
161	9	492	0.9	90*	132ML 4
145	10.0	568	1.7	100	132ML4
143	10.1	553	0.9	90*	132ML 4
143	10.2	579	3.1	125	132ML4
127	11.5	625	0.8	90*	132ML 4
123	11.8	641	1.3	112	132ML 4
119	12.2	693	2.7	125	132ML4
119	12.2	693	1.4	100	132ML4
111	13.1	715	1.2	112	132ML 4
99	14.6	834	2.6	125	132ML4
99	14.6	834	1.4	100	132ML4
92	15.7	895	3.0	150	132ML 4
92	15.7	857	0.8	90*	132ML 4
91	16.0	910	1.9	132	132ML 4
90	16.1	878	1.3	112	132ML 4
85	17.0	966	2.4	125	132ML4
85	17.0	966	1.2	100	132ML4
82	17.7	968	0.8	90*	132ML 4
81	17.9	979	1.3	112	132ML 4
81	17.9	1022	1.8	132	132ML 4
78	18.6	1061	3.0	150	132ML 4
72	20.3	1153	1.7	132	132ML 4
69	20.9	1141	1.1	112	132ML 4
68	21.2	1208	1.8	125	132ML4
68	21.2	1208	1.0	100	132ML4
67	21.6	1228	3.2	150	132ML 4
67	21.7	1233	1.8	132	132ML 4
63	22.9	1302	3.2	150	132ML 4
61	23.6	1288	1	112	132ML 4
60	24.3	1385	1.7	132	132ML 4
59	24.6	1400	1.6	125	132ML4
59	24.6	1400	0.9	100	132ML4
59	24.6	1402	3.1	140	132ML4
57	25.6	1395	1	112	132ML 4
56	25.9	1472	3.1	150	132ML 4
53	27.5	1563	1.7	132	132ML 4
49	29.4	1604	1.1	112	132ML 4
48	30.3	1725	2.9	150	132ML 4
47	31.2	1776	1.8	132	132ML 4
45	31.9	1819	1.2	125	132ML4
44	32.8	1788	1	112	132ML 4
43	33.4	1902	2.3	140	132ML4
42	34.5	1964	2.5	150	132ML 4
40	36.3	2067	1.7	132	132ML 4
39	36.9	2103	2.4	150	132ML 4
38	38.2	2085	0.8	112	132ML 4
36	40.5	2304	0.9	125	132ML4
36	40.7	2319	1.8	140	132ML4
35	41.7	2377	1.5	132	132ML 4
35	41.8	2383	3.1	170	132ML 4
34	42.6	2429	2.1	150	132ML 4
32	44.9	2559	1.4	132	132ML 4



1.7 Prestazioni motoriduttori

1.7 Gearmotors performances

1.7 Leistungen der Getriebemotoren

n_2 min ⁻¹	ir	T2 Nm	FS'	OM-OC	
----------------------------	----	----------	-----	-------	--

18.5 kW	$n_1 = 2910 \text{ min}^{-1}$	160L 2
	$n_1 = 1460 \text{ min}^{-1}$	180M 4
	$n_1 = 970 \text{ min}^{-1}$	200L 6

58	25.2	2950	3.3	190	180M 4
58	25.2	2950	2.5	170	180M 4
56	25.9	3020	1.5	150	180M 4
53	27.5	3207	0.8	132	180M 4
51	28.8	3365	3.0	190	180M 4
51	28.8	3365	2.2	170	180M 4
48	30.3	3539	1.4	150	180M 4
47	30.9	3605	2.8	190	180M 4
47	30.9	3605	2.1	170	180M 4
47	31.2	3642	0.9	132	180M 4
44	33.4	3942	1.1	140	180M 4
42	34.5	4029	1.2	150	180M 4
41	35.7	4171	2.5	190	180M 4
41	35.7	4171	1.8	170	180M 4
40	36.3	4239	0.8	132	180M 4
40	36.9	4313	1.2	150	180M 4
36	40.7	4806	0.9	140	180M 4
35	41.7	4875	0.7	132	180M 4
35	41.8	4887	2.1	190	180M 4
35	41.8	4887	1.5	170	180M 4
34	42.6	4981	1.0	150	180M 4
32	44.9	5250	0.7	132	180M 4
32	45.6	5322	2.0	190	180M 4
32	45.6	5322	1.4	170	180M 4
32	46.0	5378	0.9	150	180M 4
29	49.8	5824	1.8	190	180M 4
29	49.8	5824	1.3	170	180M 4
27	54.3	6342	1.7	190	180M 4
27	54.3	6342	1.2	170	180M 4
25	59.4	6934	0.7	150	180M 4
23	64.0	7481	1.4	190	180M 4
23	64.0	7481	1.0	170	180M 4
21	68.9	8050	1.3	190	180M 4
21	68.9	8050	0.9	170	180M 4
19.5	75.0	8766	0.9	170	180M 4
19.5	75.0	8766	1.2	190	180M 4
17.9	81.7	9547	1.1	190	180M 4
17.9	81.7	9547	0.8	170	180M 4
16.3	89.4	10447	1.0	190	180M 4
16.3	89.4	10447	0.7	170	180M 4
14.9	97.9	11432	0.9	190	180M 4
14.8	98.4	11497	0.7	170	180M 4
12.8	113.9	13309	0.8	190	180M 4
11.8	124.1	14494	0.7	190	180M 4
10.8	135.8	15861	0.7	190	180M 4

n_2 min ⁻¹	ir	T2 Nm	FS'	OM-OC	
----------------------------	----	----------	-----	-------	--

22 kW	$n_1 = 2925 \text{ min}^{-1}$	180M 2
	$n_1 = 1460 \text{ min}^{-1}$	180L 4
	$n_1 = 975 \text{ min}^{-1}$	200L 6

568	5.2	351	2.6	125*	180M 2
394	7.4	506	2.4	125*	180M 2
288	10.2	693	2.4	125*	180M 2
283	5.2	704	1.4	125*	180L 4
240	12.2	830	2.1	125*	180M 2
200	14.6	999	2.0	125*	180M 2
197	7.4	1014	1.3	125*	180L 4
196	14.9	1020	3.8	140	180M 2
189	15.5	1045	4.0	170	180M 2
186	15.7	1061	2.3	150	180M 2
183	16.0	1078	1.4	132	180M 2
172	17.0	1157	1.8	125*	180M 2
167	17.5	1181	3.9	170	180M 2
163	17.9	1211	1.4	132	180M 2
157	18.6	1258	2.3	150	180M 2
145	20.2	1378	2.8	140	180M 2
144	20.3	1367	1.3	132	180M 2
144	10.2	1389	1.3	125*	180L 4
142	10.3	1406	2.8	140	180L 4
138	21.2	1447	1.4	125*	180M 2
136	21.6	1455	2.5	150	180M 2
135	21.7	1462	1.4	132	180M 2
128	22.9	1544	2.5	150	180M 2
123	23.7	1600	4.0	170	180M 2
120	24.3	1642	1.3	132	180M 2
120	12.2	1663	1.1	125*	180L 4
119	12.3	1676	2.4	140	180L 4
119	24.6	1678	1.3	125*	180M 2
119	24.6	1680	2.3	140	180M 2
116	25.2	1705	4.0	170	180M 2
113	25.9	1746	2.4	150	180M 2
107	27.5	1853	1.3	132	180M 2
102	28.8	1945	3.5	170	180M 2
100	14.6	2001	1.1	125*	180L 4
98	14.9	2043	2.1	140	180L 4
94	15.5	2094	3.1	190	180L 4
94	15.5	2094	2.2	170	180L 4
93	15.7	2125	1.3	150	180L 4
93	15.7	2125	1.3	150	180L 4
92	31.9	2180	0.9	125*	180M 2
91	16.0	2161	0.8	132	180L 4
91	16.0	2161	0.8	132	180L 4
88	33.4	2278	1.8	140	180M 2
86	17.0	2319	1.0	125*	180L 4
83	17.5	2365	3.0	190	180L 4
83	17.5	2365	3.0	190	180L 4
83	17.5	2365	3.0	190	180L 4
83	17.5	2365	2.1	170	180L 4
83	17.5	2365	2.1	170	180L 4
83	17.5	2365	2.1	170	180L 4
81	17.9	2427	0.7	132	180L 4
81	17.9	2427	0.7	132	180L 4
81	17.9	2427	0.7	132	180L 4
78	18.6	2519	3.1	190	180L 4
78	18.6	2519	3.1	190	180L 4
78	18.6	2519	3.1	190	180L 4
78	18.6	2519	2.2	170	180L 4
78	18.6	2519	2.2	170	180L 4

n_2 min ⁻¹	ir	T2 Nm	FS'	OM-OC	
----------------------------	----	----------	-----	-------	--

22 kW	$n_1 = 2925 \text{ min}^{-1}$	180M 2
	$n_1 = 1460 \text{ min}^{-1}$	180L 4
	$n_1 = 975 \text{ min}^{-1}$	200L 6

78	18.6	2519	2.2	170	180L 4
78	18.6	2520	1.3	150	180L 4
78	18.6	2520	1.3	150	180L 4
78	18.6	2520	1.3	150	180L 4
72	20.2	2760	1.5	140	180L 4
72	20.3	2739	0.7	132	180L 4
72	20.3	2739	0.7	132	180L 4
72	20.3	2739	0.7	132	180L 4
72	40.7	2778	1.4	140	180M 2
68	21.6	2915	1.3	150	180L 4
68	21.6	2915	1.3	150	180L 4
68	21.6	2915	1.3	150	180L 4
67	21.7	2929	0.8	132	180L 4
67	21.7	2929	0.8	132	180L 4
64	22.9	3093	1.4	150	180L 4
64	22.9	3093	1.4	150	180L 4
64	22.9	3093	1.4	150	180L 4
62	23.7	3206	3.0	190	180L 4
62	23.7	3206	3.0	190	180L 4
62	23.7	3206	2.2	170	180L 4
62	23.7	3206	2.2	170	180L 4
60	24.3	3290	0.7	132	180L 4
60	24.3	3290	0.7	132	180L 4
59	24.6	3366	1.3	140	180L 4
58	25.2	3415	2.9	190	180L 4
58	25.2	3415	2.9	190	180L 4
58	25.2	3415	2.2	170	180L 4
58	25.2	3415	2.2	170	180L 4
57	51.3	3499	1.2	140	180M 2
56	25.9	3497	1.3	150	180L 4
56	25.9	3497	1.3	150	180L 4
56	25.9	3497	1.3	150	180L 4
53	27.5	3713	0.7	132	180L 4
53	27.5	3713	0.7	132	180L 4
51	57.4	3917	1.0	140	180M 2
51	28.8	3896	2.6	190	180L 4
51	28.8	3896	2.6	190	180L 4
51	28.8	3896	1.9	170	180L 4
51	28.8	3896	1.9	170	180L 4
48	30.3	4098	1.2	150	180L 4
48	30.3	4098	1.2	150	180L 4
47	30.9	4174	2.5	190	180L 4
47	30.9	4174	2.5	190	180L 4
47	30.9	4174	1.8	170	180L 4
47	30.9	4174	1.8	170	180L 4
47	31.2	4217	0.7	132	180L 4
47	31.2	4217	0.7	132	180L 4
44	33.4	4564	1.0	140	180L 4
42	34.5	4666	1.1	150	180L 4
41	35.7	4829	2.2	190	180L 4
41	35.7	4829	1.6	170	180L 4
40	36.3	4908	0.7	132	180L 4
40	36.3	4908	0.7	132	180L 4
40	36.9	4994	1.0	150	180L 4
40	36.9	4994	1.0	150	180L 4
35	41.8	5658	1.9	190	180L 4
35	41.8	5658	1.9	190	180L 4



1.7 Prestazioni motoriduttori

1.7 Gearmotors performances

1.7 Leistungen der Getriebemotoren

n_2 min ⁻¹	ir	T2 Nm	FS'	OM-OC	
----------------------------	----	----------	-----	-------	--

22 kW	$n_1= 2925 \text{ min}^{-1}$ $n_1= 1460 \text{ min}^{-1}$ $n_1= 975 \text{ min}^{-1}$	180M 2 180L 4 200L 6
--------------	---	----------------------------

35	41.8	5658	1.3	170	180L 4
35	41.8	5658	1.3	170	180L 4
34	42.6	5768	0.9	150	180L 4
34	42.6	5768	0.9	150	180L 4
32	45.6	6162	1.7	190	180L 4
32	45.6	6162	1.2	170	180L 4
32	45.6	6162	1.2	170	180L 4
32	46.0	6227	0.8	150	180L 4
29	49.8	6743	1.6	190	180L 4
29	49.8	6743	1.6	190	180L 4
29	49.8	6743	1.1	170	180L 4
27	54.3	7343	0.7	150	180L 4
27	54.3	7343	0.7	150	180L 4
27	54.3	7343	1.4	190	180L 4
27	54.3	7343	1.4	190	180L 4
27	54.3	7343	1.0	170	180L 4
27	54.3	7343	1.0	170	180L 4
23	64.0	8663	1.2	190	180L 4
23	64.0	8663	0.9	170	180L 4
23	64.0	8663	0.9	170	180L 4
21	68.9	9321	1.1	190	180L 4
21	68.9	9321	1.1	190	180L 4
21	68.9	9321	0.8	170	180L 4
19.5	75.0	10151	0.7	170	180L 4
19.5	75.0	10151	0.7	170	180L 4
19.5	75.0	10151	1.0	190	180L 4
19.5	75.0	10151	1.0	190	180L 4
17.9	81.7	11054	0.9	190	180L 4
17.9	81.7	11054	0.7	170	180L 4
17.9	81.7	11054	0.7	170	180L 4
16.3	89.4	12096	0.9	190	180L 4
14.9	97.9	13237	0.8	190	180L 4
12.8	113.9	15411	0.7	190	180L 4
12.8	113.9	15411	0.7	190	180L 4

30 kW	$n_1= 2945 \text{ min}^{-1}$ $n_1= 1465 \text{ min}^{-1}$	200L 2 200L 4
--------------	--	------------------

240	12.3	1133	3.3	140*	200L 2
197	14.9	1381	2.8	140*	200L 2
193	7.6	1410	2.8	140*	200L 4
190	15.5	1416	3.0	170	200L 2
187	15.7	1437	1.7	150	200L 2
168	17.5	1599	2.9	170	200L 2
158	18.6	1703	3.0	170	200L 2
158	18.6	1704	1.7	150	200L 2
146	20.2	1866	2.1	140*	200L 2
142	10.3	1911	2.1	140*	200L 4
137	21.6	1971	1.8	150	200L 2
129	22.9	2091	1.8	150	200L 2
124	23.7	2168	3.0	170	200L 2
120	24.6	2275	1.7	140*	200L 2
120	12.3	2277	1.8	140*	200L 4
117	25.2	2309	3.0	170	200L 2
114	25.9	2364	1.7	150	200L 2
102	28.8	2634	3.5	190	200L 2
102	28.8	2634	2.6	170	200L 2

n_2 min ⁻¹	ir	T2 Nm	FS'	OM-OC	
----------------------------	----	----------	-----	-------	--

30 kW	$n_1= 2945 \text{ min}^{-1}$ $n_1= 1465 \text{ min}^{-1}$	200L 2 200L 4
--------------	--	------------------

98	14.9	2777	1.5	140*	200L 4
95	15.5	2846	2.3	190	200L 4
95	15.5	2846	1.6	170	200L 4
93	15.7	2888	0.9	150	200L 4
88	33.4	3085	1.3	140*	200L 2
84	17.5	3214	2.2	190	200L 4
84	17.5	3214	1.6	170	200L 4
79	18.6	3424	2.3	190	200L 4
79	18.6	3424	1.6	170	200L 4
79	18.6	3425	0.9	150	200L 4
73	20.2	3751	1.1	140*	200L 4
72	40.7	3762	1.0	140*	200L 2
68	21.6	3962	1.0	150	200L 4
64	22.9	4203	1.0	150	200L 4
62	23.7	4357	2.2	190	200L 4
62	23.7	4357	1.6	170	200L 4
60	24.6	4574	0.9	140*	200L 4
58	25.2	4641	2.1	190	200L 4
58	25.2	4641	1.6	170	200L 4
57	51.3	4740	0.9	140*	200L 2
57	25.9	4752	0.9	150	200L 4
51	57.4	5305	0.7	140*	200L 2
51	28.8	5295	1.9	190	200L 4
51	28.8	5295	1.4	170	200L 4
48	30.3	5569	0.9	150	200L 4
47	30.9	5673	1.8	190	200L 4
47	30.9	5673	1.3	170	200L 4
44	33.4	6202	0.7	140	200L 4
42	34.5	6340	0.8	150	200L 4
41	35.7	6563	1.6	190	200L 4
41	35.7	6563	1.1	170	200L 4
40	36.9	6787	0.7	150	200L 4
35	41.8	7690	1.4	190	200L 4
35	41.8	7690	1.0	170	200L 4
32	45.6	8374	1.3	190	200L 4
32	45.6	8374	0.9	170	200L 4
29	49.8	9164	1.1	190	200L 4
29	49.8	9164	0.8	170	200L 4
27	54.3	9979	1.1	190	200L 4
27	54.3	9979	0.8	170	200L 4
23	64.0	11773	0.9	190	200L 4
21	68.9	12667	0.8	190	200L 4
20	75.0	13794	0.8	190	200L 4
17.9	81.7	15022	0.7	190	200L 4

n_2 min ⁻¹	ir	T2 Nm	FS'	OM-OC	
----------------------------	----	----------	-----	-------	--

37 kW	$n_1= 2950 \text{ min}^{-1}$ $n_1= 1475 \text{ min}^{-1}$	200L 2 225S 4
--------------	--	------------------

389	7.6	863	4.2	140*	200L 2
287	10.3	1170	3.1	140*	200L 2
241	12.3	1395	2.7	140*	200L 2
197	14.9	1701	2.3	140*	200L 2
191	15.5	1743	3.4	190	200L 2
191	15.5	1743	2.4	170	200L 2
188	15.7	1769	1.4	150	200L 2
169	17.5	1969	3.3	190	200L 2
169	17.5	1969	2.3	170	200L 2
158	18.6	2097	3.4	190	200L 2
158	18.6	2097	2.4	170	200L 2
158	18.6	2098	1.4	150	200L 2
146	20.2	2298	1.7	140*	200L 2
137	21.6	2427	1.5	150	200L 2
129	22.9	2575	1.5	150	200L 2
124	23.7	2669	3.3	190	200L 2
124	23.7	2669	2.4	170	200L 2
120	24.6	2802	1.4	140*	200L 2
117	25.2	2843	3.2	190	200L 2
117	25.2	2843	2.4	170	200L 2
114	25.9	2911	1.4	150	200L 2
102	28.8	3243	2.8	190	200L 2
102	28.8	3243	2.1	170	200L 2
95	15.5	3486	1.8	190	225S 4
95	15.5	3486	1.3	170	225S 4
88	33.4	3799	1.1	140*	200L 2
84	17.5	3938	1.8	190	225S 4
84	17.5	3938	1.3	170	225S 4
79	18.6	4194	1.9	190	225S 4
79	18.6	4194	1.3	170	225S 4
72	40.7	4632	0.8	140*	200L 2
62	23.7	5338	1.8	190	225S 4
62	23.7	5338	1.3	170	225S 4
58	25.2	5686	1.7	190	225S 4
58	25.2	5686	1.3	170	225S 4
58	51.3	5836	0.7	140	200L 2
51	28.8	6486	1.5	190*	225S 4
51	28.8	6486	1.2	170	225S 4
48	30.9	6949	1.5	190	225S 4
48	30.9	6949	1.1	170	225S 4
41	35.7	8039	1.3	190	225S 4
41	35.7	8039	0.9	170	225S 4
35	41.8	9420	1.1	190	225S 4
35	41.8	9420	0.8	170	225S 4
32	45.6	10258	1.0	190	225S 4
32	45.6	10258	0.7	170	225S 4
30	49.8	11225	0.9	190	225S 4
30	49.8	11225	0.7	170	225S 4
27	54.3	12224	0.9	190	225S 4
23	64.0	14421	0.7	190	225S 4
21	68.9	15517	0.7	190	225S 4



1.7 Prestazioni motoriduttori

1.7 Gearmotors performances

1.7 Leistungen der Getriebemotoren

n_2 min ⁻¹	ir	T2 Nm	FS'	OM-OC	
----------------------------	----	----------	-----	-------	--

45 kW	$n_1 = 2945 \text{ min}^{-1}$	225M 2
	$n_1 = 1475 \text{ min}^{-1}$	225M 4

190	15.5	2123	2.0	170*	225M 2
190	15.5	2123	2.8	190*	225M 2
168	17.5	2399	1.9	170*	225M 2
168	17.5	2399	2.7	190*	225M 2
158	18.6	2555	2.0	170*	225M 2
158	18.6	2555	2.8	190*	225M 2
124	23.7	3251	2.0	170*	225M 2
124	23.7	3251	2.7	190*	225M 2
117	25.2	3463	2.0	170*	225M 2
117	25.2	3463	2.6	190*	225M 2
102	28.8	3951	1.7	170*	225M 2
102	28.8	3951	2.3	190*	225M 2
95	15.5	4240	1.1	170*	225M 4
95	15.5	4240	1.5	190*	225M 4
84	17.5	4789	1.0	170*	225M 4
84	17.5	4789	1.5	190*	225M 4
79	18.6	5101	1.1	170*	225M 4
79	18.6	5101	1.5	190*	225M 4
62	23.7	6492	1.1	170*	225M 4
62	23.7	6492	1.5	190*	225M 4
58	25.2	6915	1.1	170*	225M 4
58	25.2	6915	1.4	190*	225M 4
51	28.8	7888	1.0	170*	225M 4
51	28.8	7888	1.3	190*	225M 4
48	30.9	8451	0.9	170*	225M 4
48	30.9	8451	1.2	190*	225M 4
41	35.7	9777	0.8	170*	225M 4
41	35.7	9777	1.1	190*	225M 4
35	41.8	11456	0.7	170*	225M 4
35	41.8	11456	0.9	190*	225M 4
32	45.6	12476	0.8	190*	225M 4
30	49.8	13652	0.8	190*	225M 4
27	54.3	14867	0.7	190*	225M 4

n_2 min ⁻¹	ir	T2 Nm	FS'	OM-OC	
----------------------------	----	----------	-----	-------	--

75 kW	$n_1 = 2975 \text{ min}^{-1}$	280S 2
	$n_1 = 1470 \text{ min}^{-1}$	250M 4

95	15.5	7090	0.9	190*	250M 4
84	17.5	8009	0.9	190*	250M 4
79	18.6	8531	0.9	190*	250M 4
62	23.7	10856	0.9	190*	250M 4
58	25.2	11564	0.8	190*	250M 4
51	28.8	13191	0.8	190*	250M 4
48	30.9	14134	0.7	190*	250M 4

n_2 min ⁻¹	ir	T2 Nm	FS'	OM-OC	
----------------------------	----	----------	-----	-------	--

55 kW	$n_1 = 2950 \text{ min}^{-1}$	250M 2
	$n_1 = 1475 \text{ min}^{-1}$	250M 4

191	15.5	2591	2.3	190*	250M 2
169	17.5	2927	2.2	190*	250M 2
158	18.6	3117	2.3	190*	250M 2
124	23.7	3967	2.2	190*	250M 2
117	25.2	4226	2.1	190*	250M 2
102	28.8	4820	1.9	190*	250M 2
95	15.5	5182	1.2	190*	250M 4
84	17.5	5853	1.2	190*	250M 4
79	18.6	6235	1.3	190*	250M 4
62	23.7	7934	1.2	190*	250M 4
58	25.2	8451	1.2	190*	250M 4
51	28.8	9641	1.0	190*	250M 4
48	30.9	10330	1.0	190*	250M 4
41	35.7	11950	0.9	190*	250M 4
35	41.8	14002	0.7	190*	250M 4
32	45.6	15248	0.7	190*	250M 4

N.B.

Tutte le potenze indicate si riferiscono alla potenza meccanica dei riduttori.

Per i riduttori contrassegnati con (*) è opportuno effettuare la verifica della potenza limite termico secondo le indicazioni riportate nel par. A-1.5.

NOTE.

The power indicated is based on the mechanical capacities of the gearboxes. For the gearboxes marked with (*) it is also necessary to obey the thermal capacity like shown on chapter A-1.5.

HINWEIS.

Die Leistungsangaben beziehen sich auf die mechanische Belasbarkeit der Getriebe. Bei den mit (*) gekennzeichneten Getrieben ist außerdem die thermische Leistungsgrenze zu beachten (s. Kap A-1.5).





Dimensioni riduttori
Dimensions gearboxes
Abmessungen Getriebes

OM 63 - 71 - 90 - 112

OMP (63)

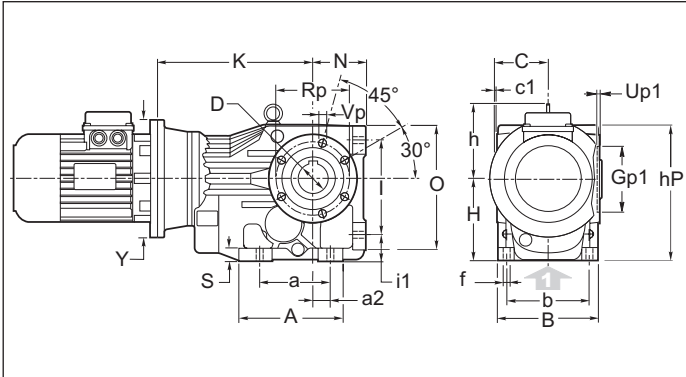

OMP (71 - 90 - 112)

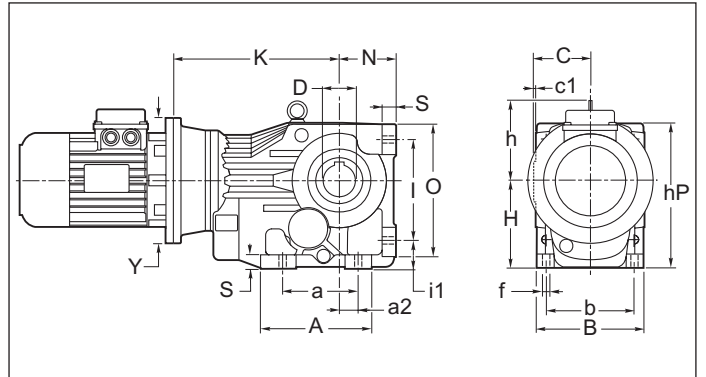

OMP P (63)

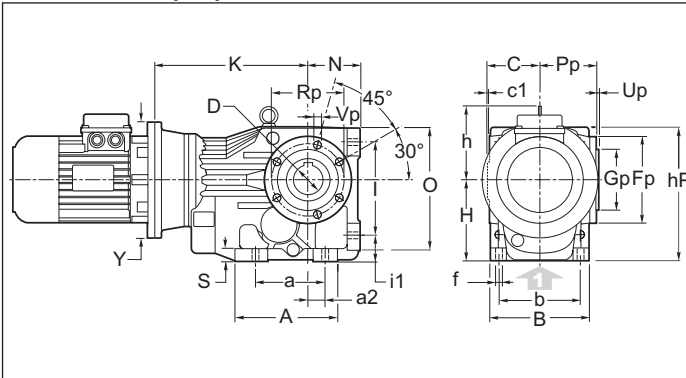

OMF P (71 - 90 - 112)

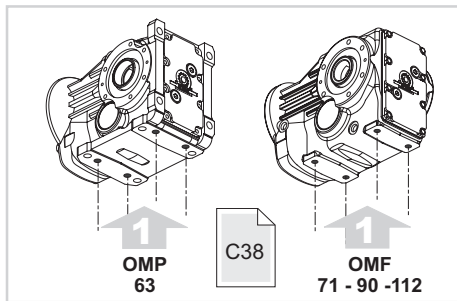
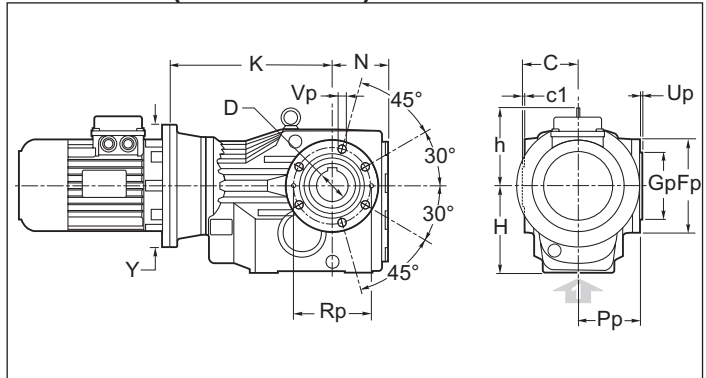

OMF (71 - 90 - 112)

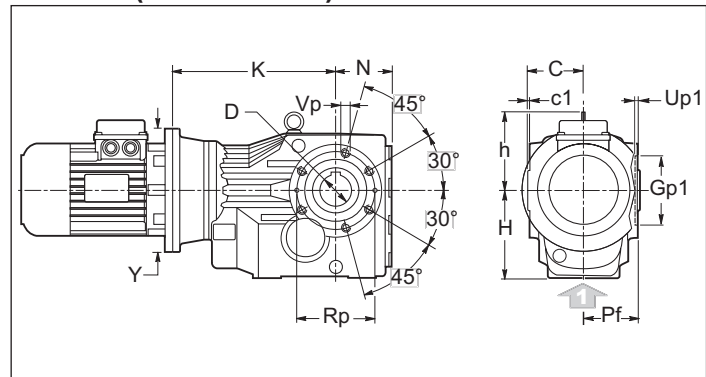

OMP F1 - F2 (63)

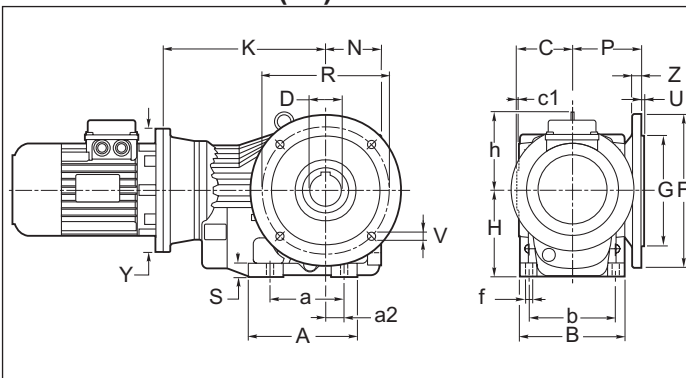

OMF F1 - F2 (71 - 90 - 112)

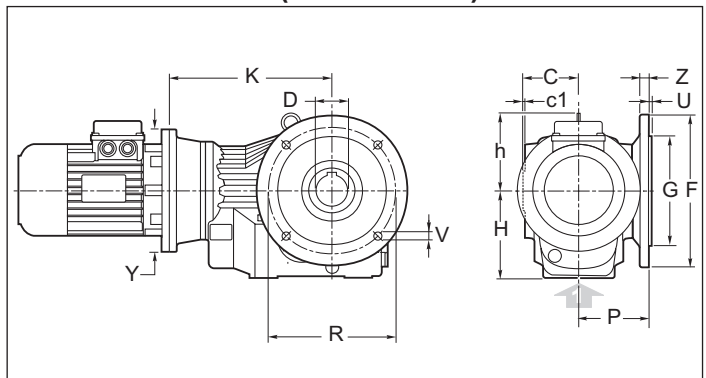



1.8 Dimensioni

1.8 Dimensions

1.8 Abmessungen

OM.	a	A	a2	b	B	C	c1	D H7	f	h	H	hP	I	i1	N	O	Pf	S
63	110	147	28	100	120	60	2,5	30 (25) (28)	11	100	100	170	115	32	63	150	57.5	14
71	130	165	35	120	142	75	3	35 (30) (32)	11	108	112	183	130	37	71	170	72	18
90	120	182	30	140	170	90	3.5	40 (42) (45) (48)	14	129	140	232	160	45	90	212	86.5	22
112	150	215	40	165	200	105	4	50 (55)	17.5	151	180	294	200	56	112	264	101	25

OM.	Gp g6	Gp1 H7	Fp	Pp	Rp	Up	Up1	Vp	F		G g6	P	R	U	V	Z
									F1	F2						
63	80	75	105	69	90	3	3.5	N°6 M6x12	F1	160	110	84	130	3.5	N°4 φ 9	10
									F2	-	-		-	-	-	
71	80	80	120	83	100	3	3.5	N°6 M8x15	F1	200	130	100	165	3.5	N°4 φ 11	12
									F2	160	110		130	3.5	N°4 φ 9x5	10
90	105	100	150	98.5	125	3.5	3.5	N°6 M12x18	F1	250	180	113	215	4	N°4 φ 13.5	15
									F2	-	-		-	-	-	
112	125	125	175	115	150	3.5	4	N°6 M14x18	F1	300	230	142	265	4	N°4 φ 13.5	16
									F2	-	-		-	-	-	

OM.	IEC	63		71		90		112		
		Y	K	Y	K	Y	K	Y	K	
	B5		140	193	140	217	160	249	200	304
		160	193	160	217	200	264	250	319	
		200	213	200	237	250	274	300	340	
		250	223	250	247	300	300	350	370	
B14			120	213	120	237	120	264	-	-
			140	213	140	237	140	264	-	-
			160	223	160	247	160	274	-	-
			-	-	-	-	200	300	-	-

Le dimensioni K si riferiscono alle combinazioni albero/flangia B5 e B14, standard.
Per le dimensioni relative a combinazioni albero/flangia arichiesta, contattare il ns. servizio tecnico.

*The K dimensions refer to the standard B5 and B14 shaft/flange combinations.
As far as the dimensions of shaft/flange combinations on request are concerned, please contact our technical department.*

Die Maße K beziehen sich auf die Kombinationen Welle/Flansch B5 und B14 Standard. Hinsichtlich der Maße von Kombinationen Welle/Flansch auf Anfrage wenden Sie sich bitte an unseren technischen Kundendienst.



1.8 Dimensioni

1.8 Dimensions

1.8 Abmessungen

Dimensioni riduttori
Dimensions gearboxes
Abmessungen Getriebes

OC 63 - 71 - 90 - 112

OCP (63)

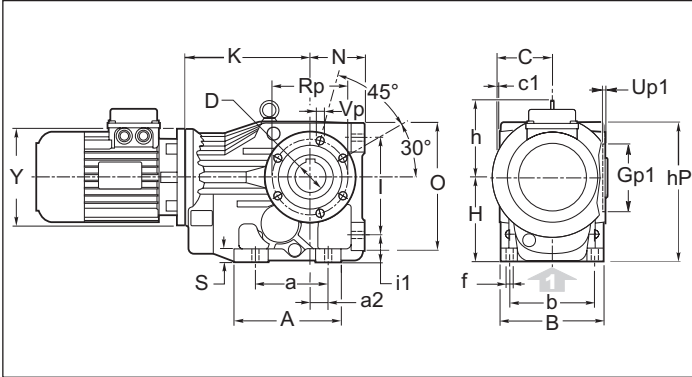

OCP (71 - 90 - 112)

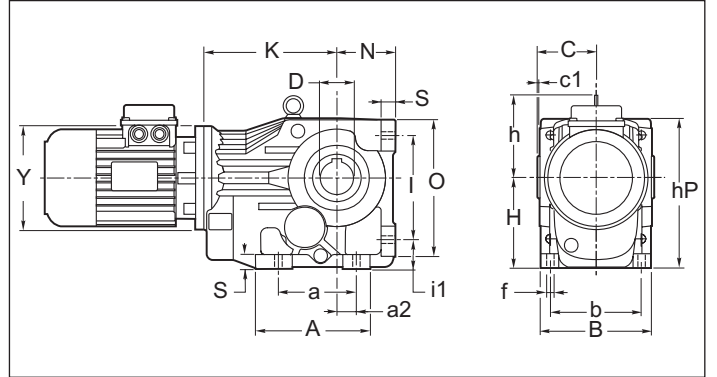

OCP P (63)

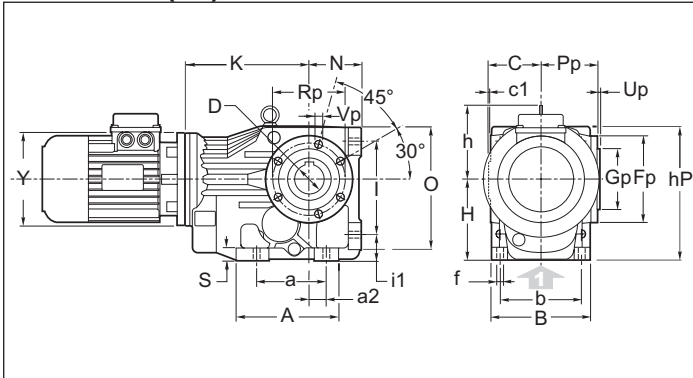

OCF P (71 - 90 - 112)

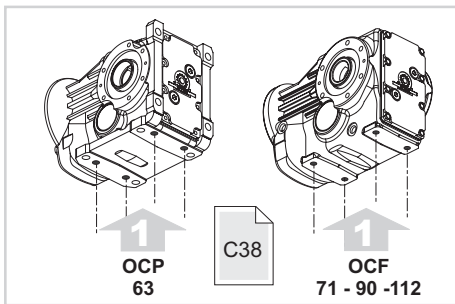
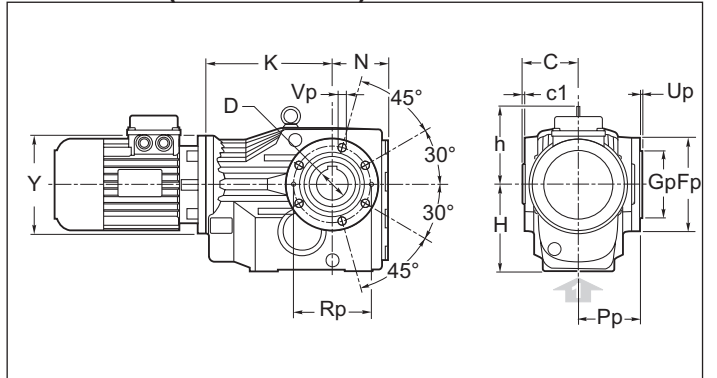

OCF (71 - 90 - 112)

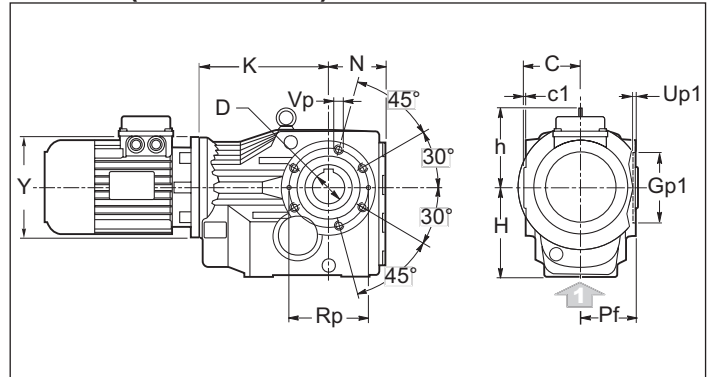

OCP F1 - F2 (63)

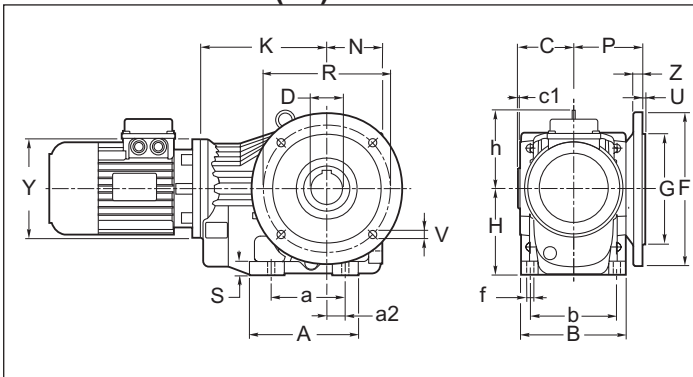

OCF F1 - F2 (71 - 90 - 112)

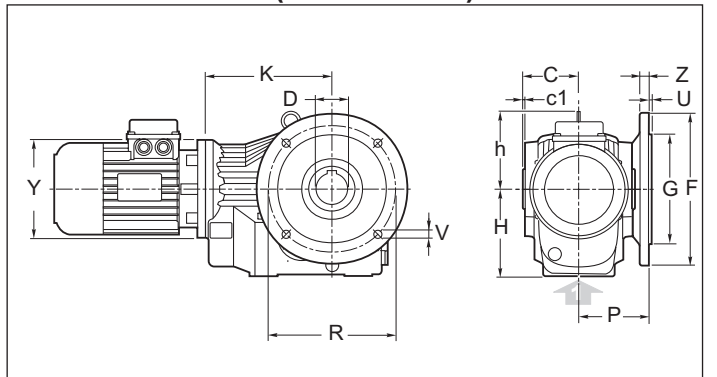

Download
2D/3D





1.8 Dimensioni

1.8 Dimensions

1.8 Abmessungen

OC.	a	A	a2	b	B	C	c1	D H7	f	h	H	hP	I	i1	N	O	Pf	S
63	110	147	28	100	120	60	2,5	30 (25) (28)	11	100	100	170	115	32	63	150	57.5	14
71	130	165	65	120	142	75	3	35 (30) (32)	11	108	112	183	130	37	71	170	72	18
90	120	182	30	140	170	90	3.5	40 (42) (45) (48)	14	129	140	232	160	45	90	212	86.5	22
112	150	215	40	165	200	105	4	50 (55)	17.5	151	180	294	200	55	112	264	101	25

OC.	Gp g6	Gp1 H7	Fp	Pp	Rp	Up	Up1	Vp	F		G g6	P	R	U	V	Z
									F1	F2						
63	80	75	105	69	90	3	3.5	N°6 M6x12	F1	160	110	84	130	3.5	N°4 φ 9	10
									F2	-						
71	80	80	120	83	100	3	3.5	N°6 M8x15	F1	200	130	100	165	3.5	N°4 φ 11	12
									F2	160						
90	105	100	150	98.5	125	3.5	3.5	N°6 M12x18	F1	250	180	113	215	4	N°4 φ 13.5	15
									F2	-						
112	125	125	175	115	150	3.5	4	N°6 M14x18	F1	300	230	142	265	4	N°4 φ 13.5	16
									F2	-						

OC.	63		71		90		112	
	Y	K	Y	K	Y	K	Y	K
	140	154	140	178	160	205	200	252

Le dimensioni K si riferiscono alle combinazioni albero/flangia B5 e B14, standard. Per le dimensioni relative a combinazioni albero/flangia arichiesta, contattare il ns. servizio tecnico.

The K dimensions refer to the standard B5 and B14 shaft/flange combinations. As far as the dimensions of shaft/flange combinations on request are concerned, please contact our technical department.

Die Maße K beziehen sich auf die Kombinationen Welle/Flansch B5 und B14 Standard. Hinsichtlich der Maße von Kombinationen Welle/Flansch auf Anfrage wenden Sie sich bitte an unseren technischen Kundendienst.



Dimensioni riduttori
Dimensions gearboxes
Abmessungen Getriebes

OR 63 - 71 - 90 - 112

ORP (63)

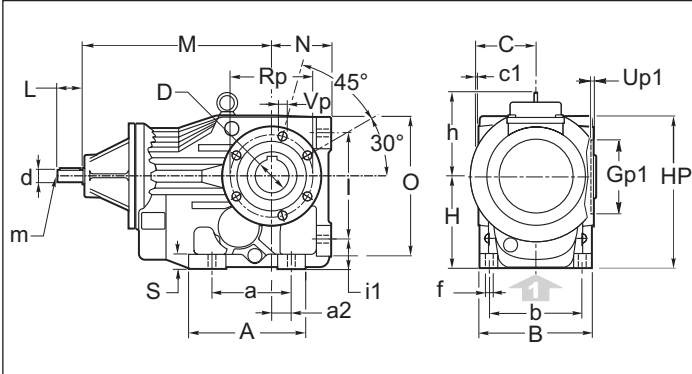

ORP (71 - 90 - 112)

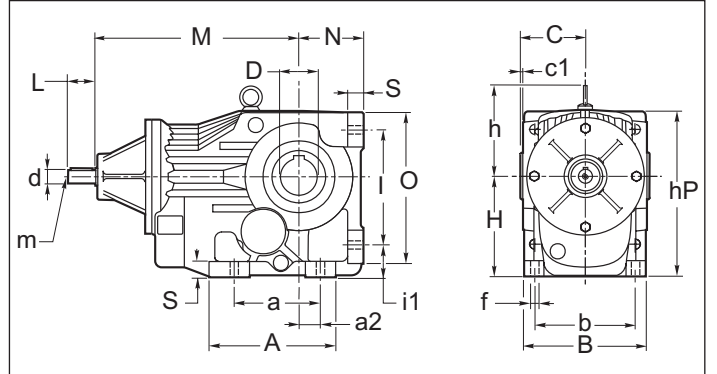

ORP P (63)

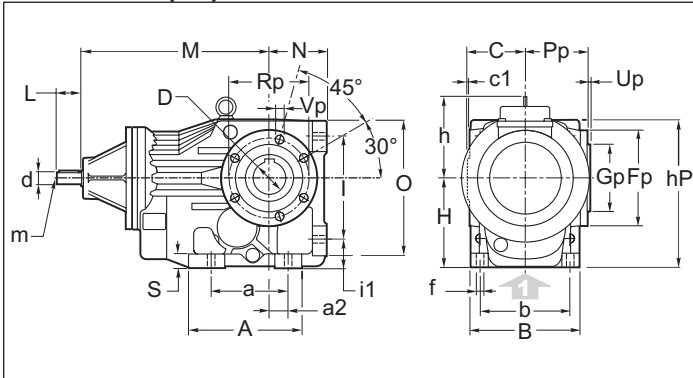

ORF P (71 - 90 - 112)

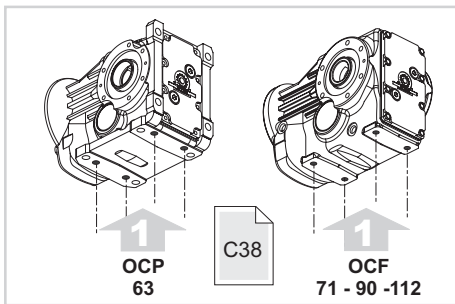
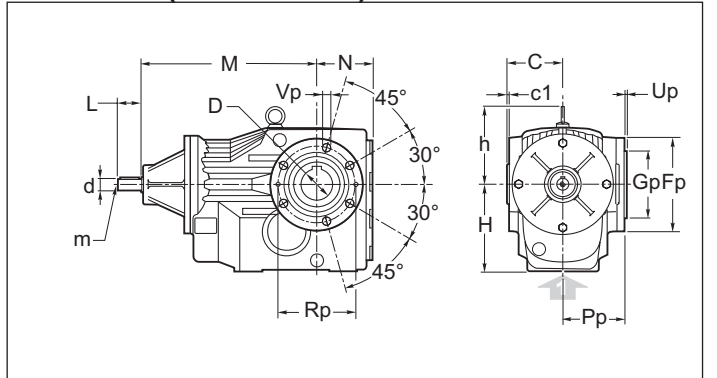

ORF (71 - 90 - 112)

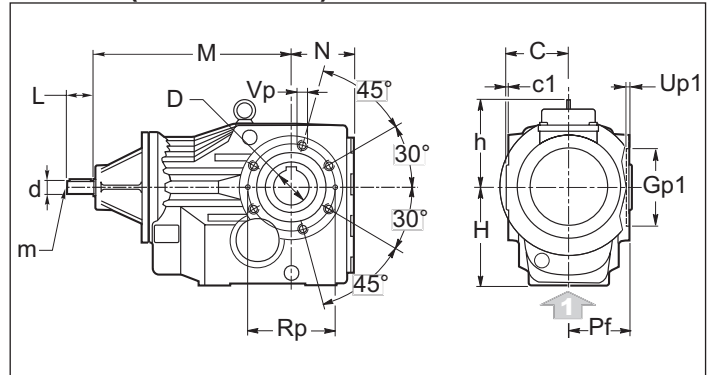

ORP F1 - F2 (63)

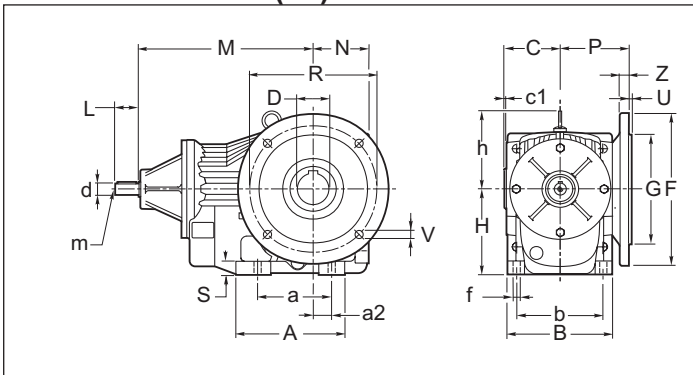

ORF F1 - F2 (71 - 90 - 112)

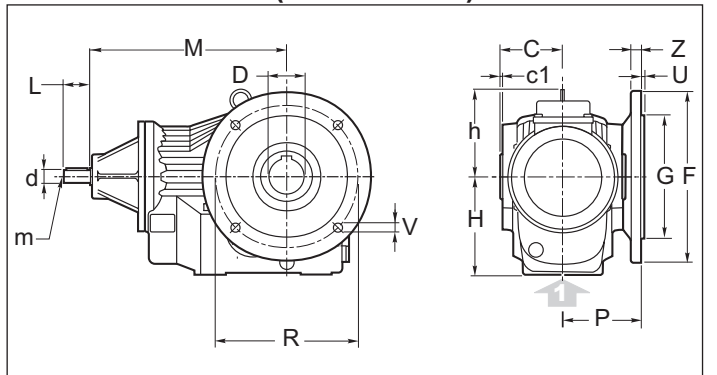

Download
2D/3D





1.8 Dimensioni

1.8 Dimensions

1.8 Abmessungen

OR.	a	A	a2	b	B	C	c1	D H7	d j6	f	h	H	hP	I	i1	L	m	M	N	O	Pf	S
63	110	147	28	100	120	60	2,5	30 (25) (28)	16	11	100	100	170	115	32	40	M6	222.5	63	150	57.5	14
71	130	165	35	120	142	75	3	35 (30) (32)	16	11	108	112	183	130	37	40	M6	246	71	170	72	18
90	120	182	30	140	170	90	3.5	40 (42) (45) (48)	19	14	129	140	232	160	45	40	M6	283	90	212	86.5	22
112	150	215	40	165	200	105	4	50 (55)	24	17.5	151	180	294	200	55	50	M8	328	112	264	101	25

OR.	Gp g6	Gp1 H7	Fp	Pp	Rp	Up	Up1	Vp	F		G g6	P	R	U	V	Z
									F1	F2						
63	80	75	105	69	90	3	3.5	N°6 M6x12	F1	160	110	84	130	3.5	N°4 φ 9	10
									F2	-	-					
71	80	80	120	83	100	3	3.5	N°6 M8x15	F1	200	130	100	165	3.5	N°4 φ 11	12
									F2	160	110		130	3.5	N°4 φ 9x5	10
90	105	100	150	98.5	125	3.5	3.5	N°6 M12x18	F1	250	180	113	215	4	N°4 φ 13.5	15
									F2	-	-		-	-	-	
112	125	125	175	115	150	3.5	4	N°6 M14x18	F1	300	230	142	265	4	N°4 φ 13.5	16
									F2	-	-		-	-	-	



Dimensioni riduttori
Dimensions gearboxes
Abmessungen Getriebes

OM 80-100-125-140

OMF

80-100
125-140

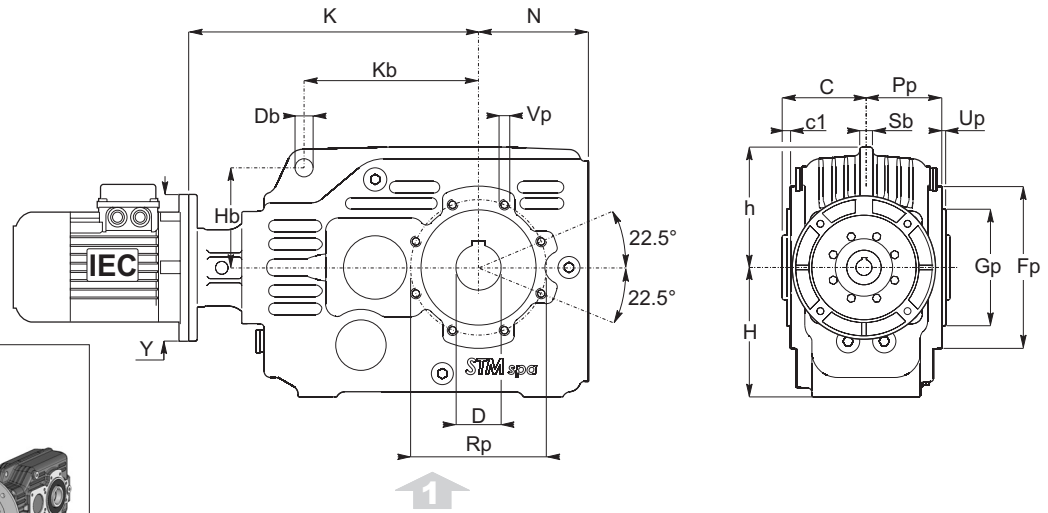

OMF F1-F2

80-100
125-140

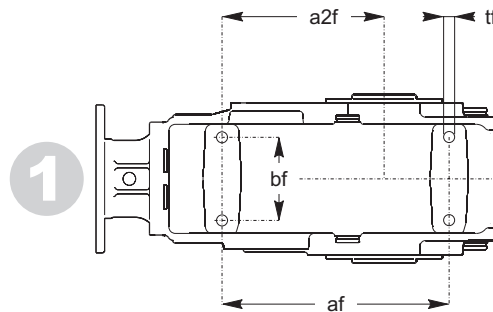
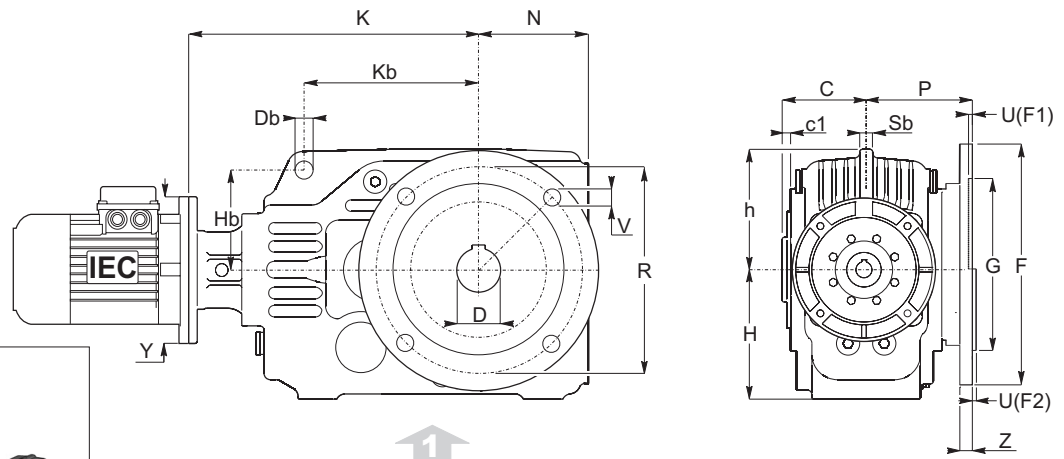



1.8 Dimensioni

1.8 Dimensions

1.8 Abmessungen

OM	af	a2f	bf	tf		C	c1	D H7	h	H	N		Db	Kb	Hb	Sb
80	175	125	64	M10		65	6,5	32 (30) (35)	93	100	85,5		13	135	77	10
100	230	159	73	M12		77,5	7,0	45 (40) (50)	113	120	105,5		13	170	95	13
125	300	210	88	M14		90	9,0	55 (50) (60)	140	145	140,5		16	215	118	15
140	390	270	130	M16		110	6,5	70 (60)	182	190	175,5		26	275	150	18

OM	Gp H7	Pp	Rp	Up	Vp	F		G F8	P	R	U	V	Z
80	90	58,5	105	3	M8	F1	200	130	100	165	4,5	11	11
100	110	70,5	125	3	M8	F1	250	180	125	215	5	13	14
125	135	81,0	150	3	M10	F1	300	230	150	265	5	15	16
						F2	350	250 (g6)	150	300	5	18	18
140	170	103,5	200	4	M12	F1	350	250	180	300	6	17	25

OM	IEC		Y	80 K	100 K	125 K	140 K
		71 B5		160	244	-	-
	80 B5		200	244	311	366	411
	80 B14		120		-	-	-
	90 B5		200	244	311	366	411
	90 B14		140		-	-	-
	100-112 B5		250	244	311	366	411
	100-112 B14		160		-	-	-
	132 B5		300	-	311	366	411
	132 B14		200				
	160 B5		350			405	469
	180 B5		350			405	469
	200 B5		400			-	474

Le dimensioni K si riferiscono alle combinazioni albero/flangia B5 e B14, standard. Per le dimensioni relative a combinazioni albero/flangia arichiesta, contattare il ns. servizio tecnico.

The K dimensions refer to the standard B5 and B14 shaft/flange combinations. As far as the dimensions of shaft/flange combinations on request are concerned, please contact our technical department.

Die Maße K beziehen sich auf die Kombinationen Welle/Flansch B5 und B14 Standard. Hinsichtlich der Maße von Kombinationen Welle/Flansch auf Anfrage wenden Sie sich bitte an unseren technischen Kundendienst.

Antiretro:

backstop device:

Rücklaufperre:

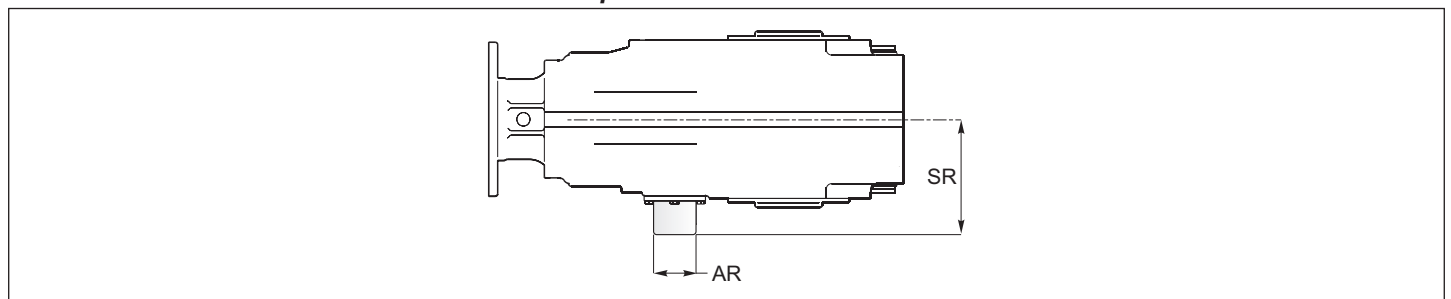

	AR	SR
80	50	72
100	55	93,5
125	60	110
140	80	124,5



Dimensioni riduttori
Dimensions gearboxes
Abmessungen Getriebes

OR 80-100-125-140

ORF

80-100 125-140

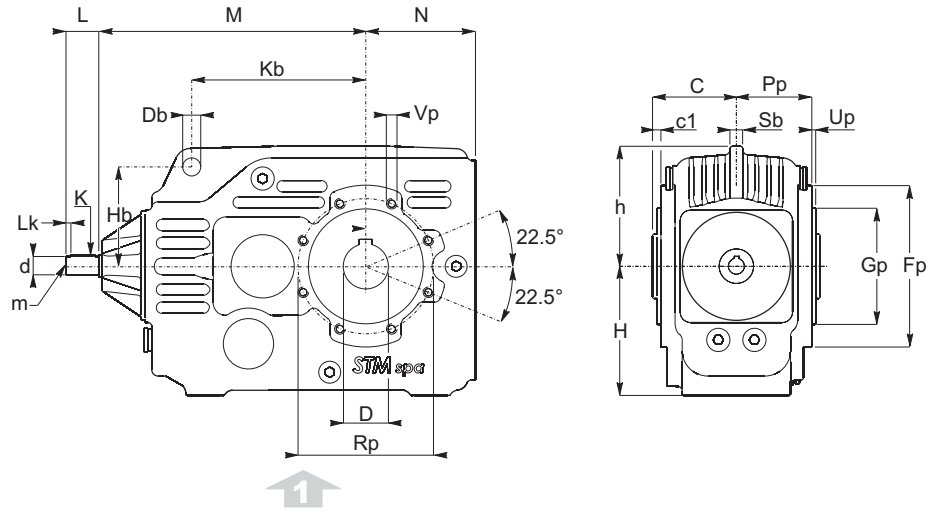
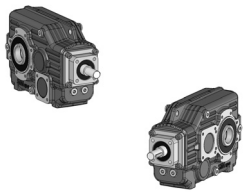

ORF

80-100 125-140

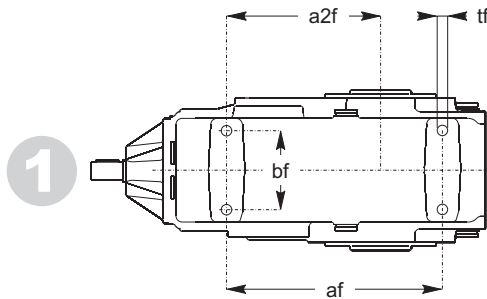
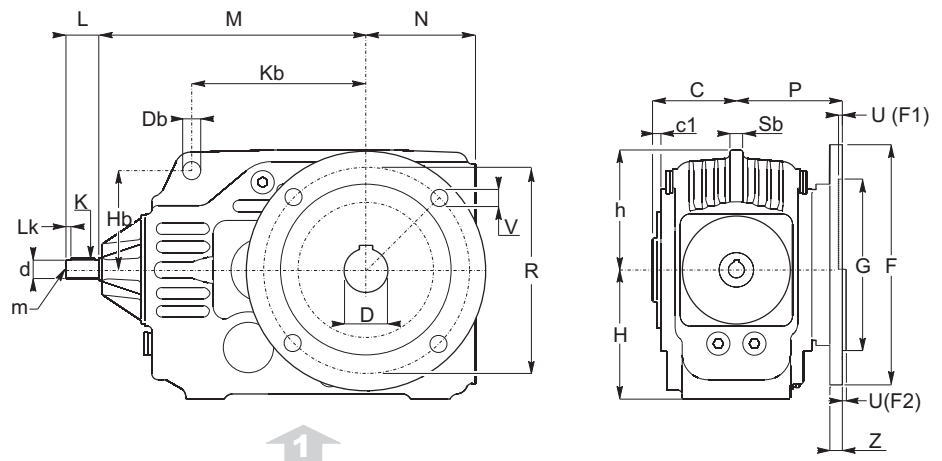
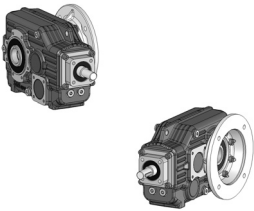



1.8 Dimensioni

1.8 Dimensions

1.8 Abmessungen

OR	af	a2f	bf	tf		C	c1	D H7	h	H	N		Db	Kb	Hb	Sb
80	175	125	64	M10		65	6,5	32 (30) (35)	93	100	85,5		13	135	77	10
100	230	159	73	M12		77,5	7,0	45 (40) (50)	113	120	105,5		13	170	95	13
125	300	210	88	M14		90	9,0	55 (50) (60)	140	145	140,5		16	215	118	15
140	390	270	130	M16		110	6,5	70 (60)	182	190	175,5		26	275	150	18

OM	Gp H7	Pp	Rp	Up	Vp		F		G F8	P	R	U	V	Z
80	90	58,5	105	3	M8		F1	200	130	100	165	4,5	11	11
100	110	70,5	125	3	M8		F1	250	180	125	215	5	13	14
125	135	81,0	150	3	M10		F1	300	230	150	265	5	15	16
						F2	350	250 (g6)	150	300	5	18	18	
140	170	103,5	200	4	M12		F1	350	250	180	300	6	17	25

OR	d	m	M	K	Lk	L
80	19 j6	M6	210	6x6x30	5	40
100	24 j6	M8	260	8x7x40	5	50
125	28 j6	M8	317	8x7x50	5	60
140	38 k6	M10	400	10x8x70	5	80

Antiretro:

backstop device:

Rücklaufperre:

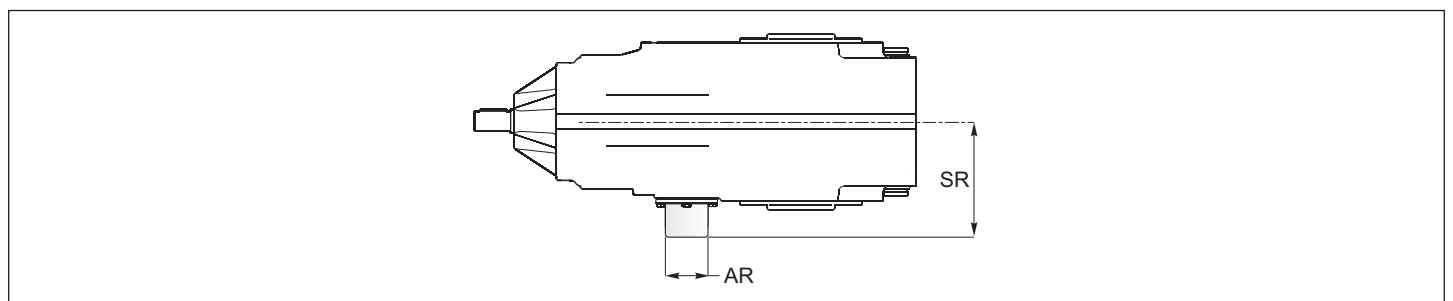

	AR	SR
80	50	72
100	55	93,5
125	60	110
140	80	124,5



1.8 Dimensioni

1.8 Dimensions

1.8 Abmessungen

Dimensioni riduttori
Dimensions gearboxes
Abmessungen Getriebes

OM 132-150-170-190

OMP

132
150
170
190

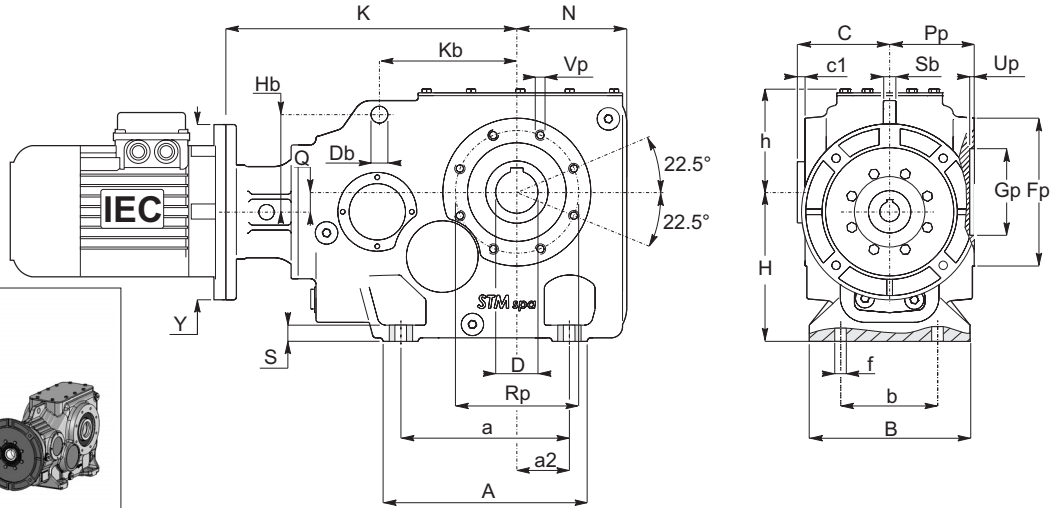
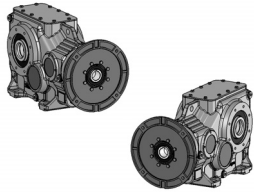

OMF

132
150
170
190

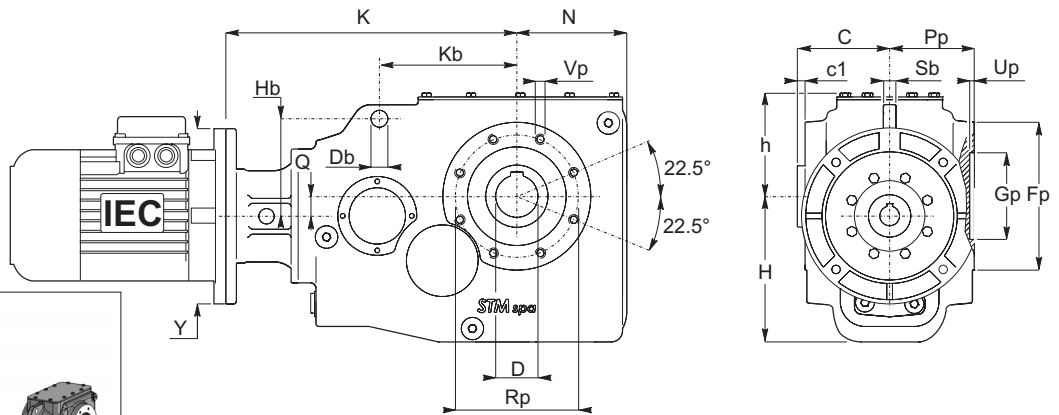
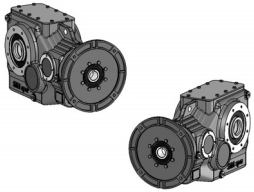

OMF F1-F2

132
150
170
190

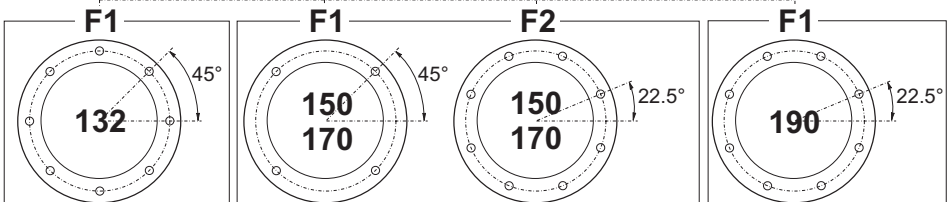
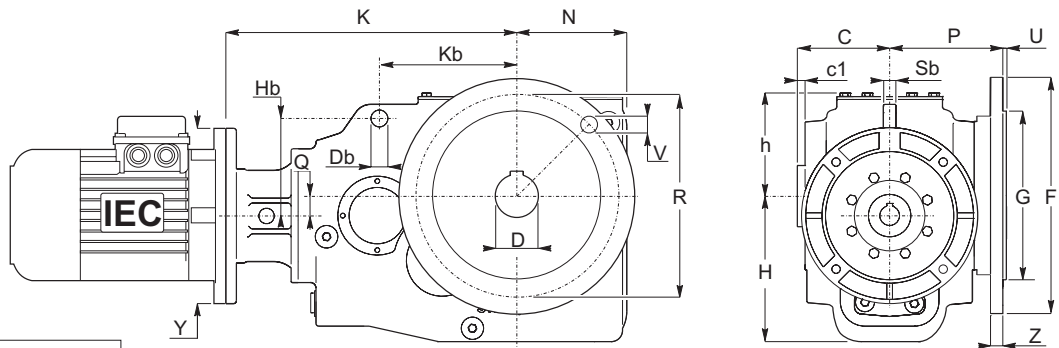
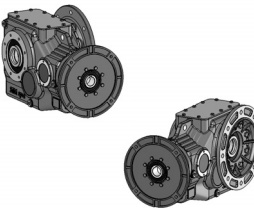



1.8 Dimensioni

1.8 Dimensions

1.8 Abmessungen

OM	a	A	a2	b	B	C	c1	D H7	f	h	H		N	Q	S	Db	Kb	Hb	Sb
											OMP	OMF							
132	240	290	75	190	228	121	1	60 (70)	22	147	212	207	156	28	23	24	195	138	18
150	270	325	90	210	255	137	4.5	70 (80)	22	170	245	240	183	30	27	26	220	155	22
170	315	375	110	240	280	151	6	90	22	188	275	270	210	35	30	32	240	175	25
190	355	425	125	270	320	170	5	100	26	208.5	315	308	236	38	35	38	276	155	30

OM	Gp H7	Fp	Pp	Rp	Up	Vp	F		G g6	P	R	U	V	Z
							F1	F2						
132	140	210	120	175	7	N° 8 M12 x 24	F1	350	250	160	300	5	N° 8 φ 18	17
150	160	240	132.5	200	7	N° 8 M14 x 28	F1	400	300	174.5	350	5	N°4 φ 18	18
							F2	450	350	174.5	400	5	N°8 φ 19	18
170	180	275	145	225	7	N°8 M16 x 32	F1	400	300	183.5	350	5	N°4 φ 18	18
							F2	450	350	183.5	400	5	N°8 φ 18	25
190	200	310	165	250	7	N°8 M18 x 36	F1	550	450	221	500	5	N°8 φ 18	25

OM	IEC B5	132		150		170		190	
		Y	K	Y	K	Y	K	Y	K
		90	200	413	-	-	-	-	-
100-112	250	413	250	455	250	485	-	-	
132	300	413	300	453	300	484	300	527.5	
160-180	350	456	350	512	350	563	350	586.5	
200	-	-	400	517	400	568	400	591.5	
225	-	-	-	-	450	577	450	632.5	
250	-	-	-	-	-	-	550	632.5	

Le dimensioni K si riferiscono alle combinazioni albero/flangia B5 e B14, standard.
Per le dimensioni relative a combinazioni albero/flangia arichiesta, contattare il ns. servizio tecnico.

The K dimensions refer to the standard B5 and B14 shaft/flange combinations.
As far as the dimensions of shaft/flange combinations on request are concerned, please contact our technical department.

Die Maße K beziehen sich auf die Kombinationen Welle/Flansch B5 und B14 Standard. Hinsichtlich der Maße von Kombinationen Welle/Flansch auf Anfrage wenden Sie sich bitte an unseren technischen Kundendienst.

Antiretro:

backstop device:

Rücklaufperre:

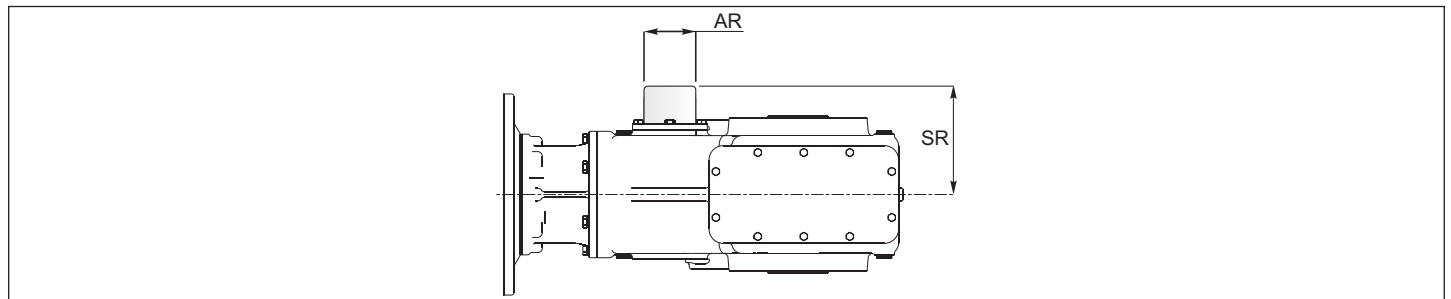

	AR	SR
132	80	155
150	90	178.5
170	100	181.75
190	110	199



1.8 Dimensioni

1.8 Dimensions

1.8 Abmessungen

Dimensioni riduttori
Dimensions gearboxes
Abmessungen Getriebes

OR 132-150-170-190

ORP

132
150
170
190

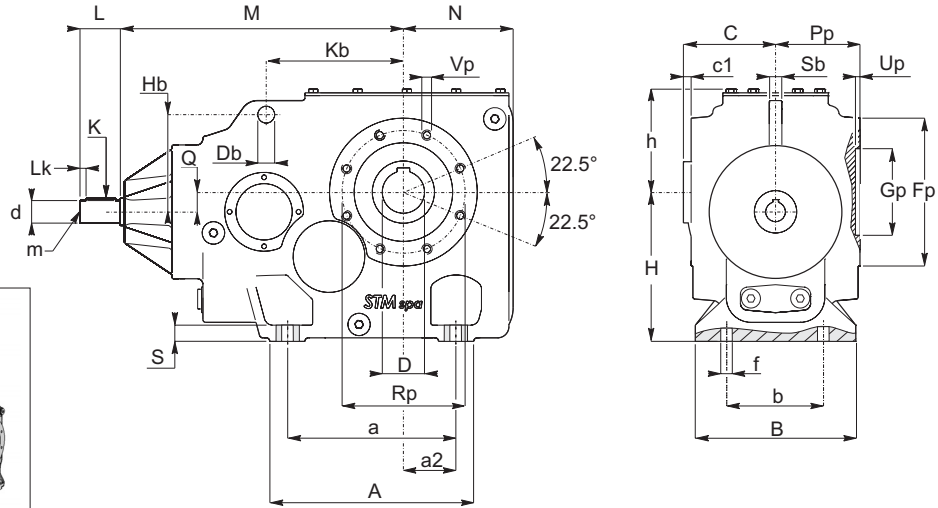
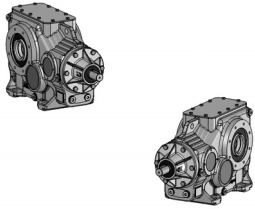

ORF

132
150
170
190

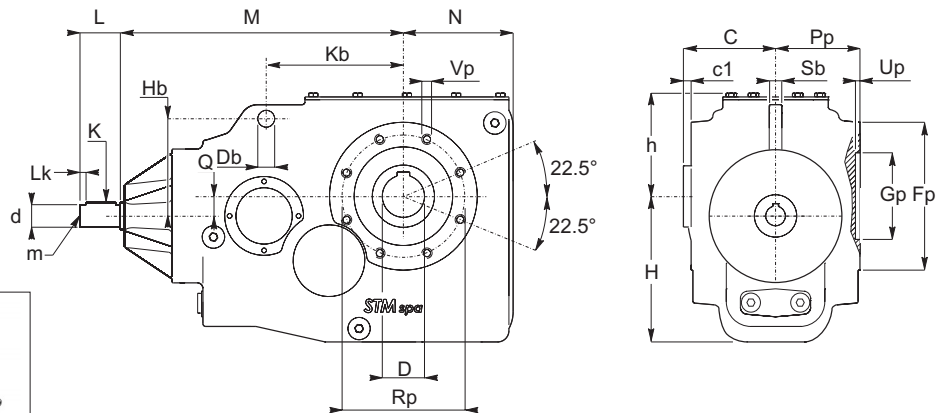
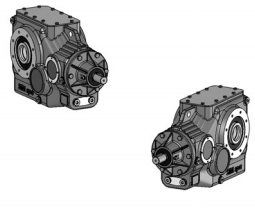

ORF F1-F2

132
150
170
190

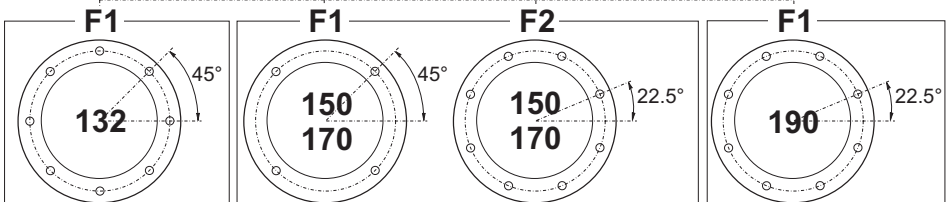
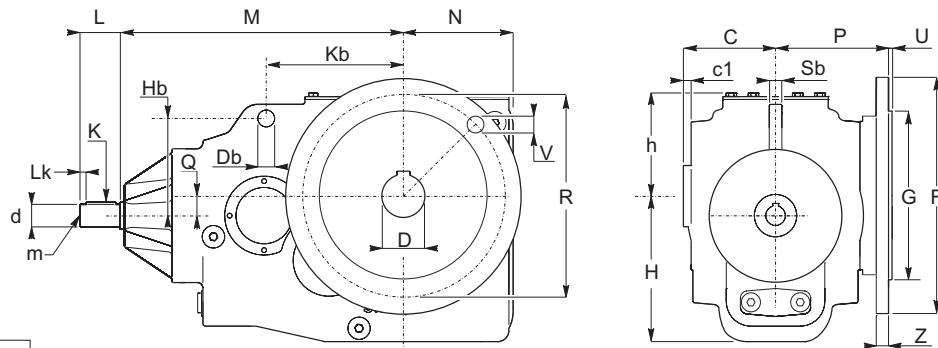
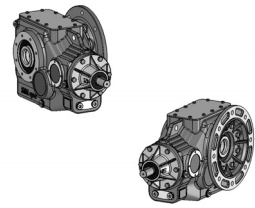



1.8 Dimensioni

1.8 Dimensions

1.8 Abmessungen

OR	a	A	a2	b	B	C	c1	D H7	f	h	H		N	Q	S	Db	Kb	Hb	Sb
											ORP	ORF							
132	240	290	75	190	228	121	1	60 (70)	22	147	212	207	156	28	23	24	195	138	18
150	270	325	90	210	255	137	4.5	70 (80)	22	170	245	240	183	30	27	26	220	155	22
170	315	375	110	240	280	151	6	90	22	188	275	270	210	35	30	32	240	175	25
190	355	425	125	270	320	170	5	100	26	208.5	315	308	236	38	35	38	276	155	30

OR	Gp H7	Fp	Pp	Rp	Up	Vp	F		G g6	P	R	U	V	Z
							F1	F2						
132	140	210	120	175	7	N° 8 M12 x 24	F1	350	250	160	300	5	N° 8 φ 18	17
150	160	240	132.5	200	7	N° 8 M14 x 28	F1	400	300	174.5	350	5	N°4 φ 18	18
							F2	450	350	174.5	400	5	N°8 φ 19	18
170	180	275	145	225	7	N°8 M16 x 32	F1	400	300	183.5	350	5	N°4 φ 18	18
							F2	450	350	183.5	400	5	N°8 φ 18	25
190	200	310	165	250	7	N°8 M18 x 36	F1	550	450	221	500	5	N°8 φ 18	25

OR	d j6	m	M	K	Lk	L
132	32	M10	390	10x8x50	5	60
150	42	M12	445	12x8x70	5	80
170	48	M12	495	14x9x90	5	100
190	60	M16	550	18x11x100	10	120

*Contattare il ns. servizio tecnico / Contact our technical dept / Wenden Sie sich an unseren technischen Service

Antiretro:

backstop device:

Rücklaufperre:

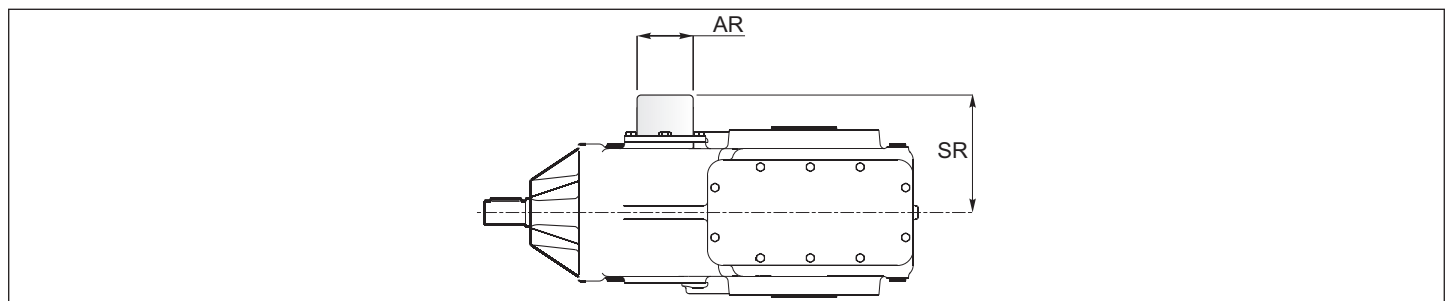

	AR	SR
132	80	155
150	90	178.5
170	100	181.75
190	110	199



PARTICOLARE CORPO IN VERSIONE FLANGIATA

Per un fissaggio del riduttore si possono utilizzare anche I 4 fori "t_F" nel piano inferiore del corpo flangiato con interasse X e Z.

DETAIL OF THE FLANGED GEARCASE

For the gearbox fixing also the 4 threads "t_F" in the lower part of the flanged gearcase with dimensions X and Z can be used

DETAIL DES GEHÄUSES MIT ABTRIEBSFLANSCH

Auch die vier Gewinde "t_F", welche sich im unteren Teil des Gehäuses befinden (mit den Maßen X und Z), können zur Montage des Getriebes verwendet werden.

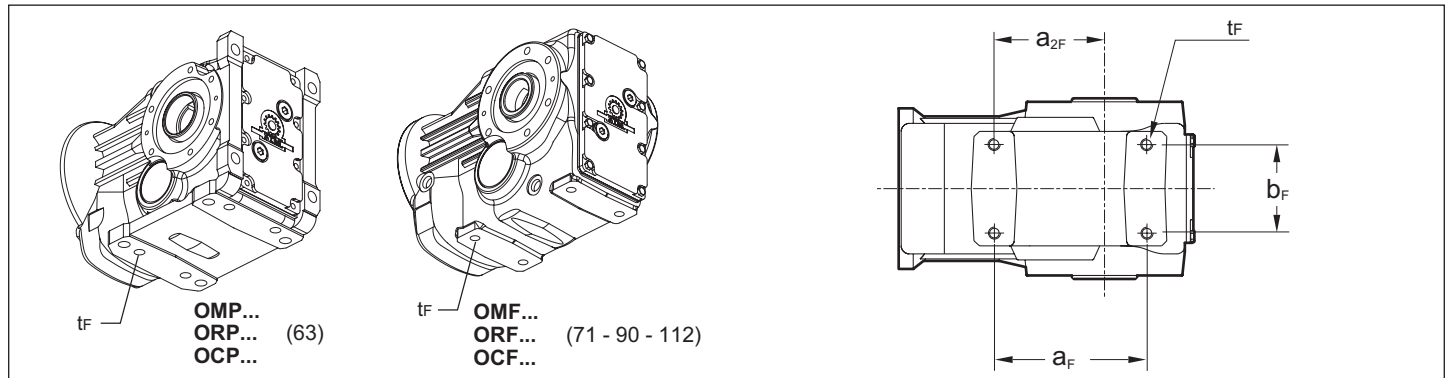

	t _F	b _F	a _F	a _{2F}
63	N°4 M10 x 15	60	117	82
71	N°4 M10 x 15	70	140	100
90	N°4 M12 x 20	88	152	110
112	N°4 M16 x 24	102	170	122

PARTICOLARE DEI FORI "t" NELLA FLANGIA P

Per il fissaggio al riduttore con i fori "Vp" considerare la lunghezza delle viti adeguate, e che la quota "yt" non è filettata (vedi disegno).

DETAIL "t" OF THE FLANGE P HOLES

When P-flange is used please consider that the threads "Vp" are in gearcase and that distance "yt" does not have a thread (see drawing).

DETAIL "t" OF THE FLANGE P HOLES

Bei Verwendung des P-Flansches ist zu beachten, daß sich die Gewinde im Getriebegehäuse befinden und daß Maß "yt" kein Gewinde besitzt. Details siehe Zeichnung.

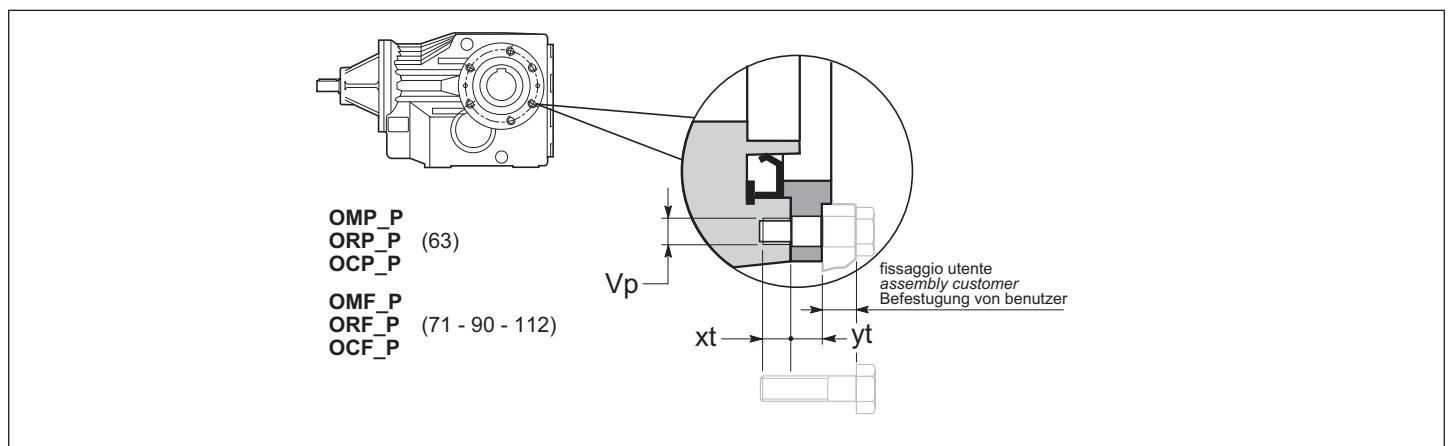

	Vp	xt	yt
63	N°6 M6	12	11,5
71	N°6 M8	15	11
90	N°6 M12	18	12
112	N°6 M14	23	14

N.B.
xt = profondità della parte filettata, utile per il fissaggio delle viti

NOTE.
xt = thread length.

HINWEIS.
xt = Gewindetiefe

ALBERI LENTI

OUTPUT SHAFT

ABTRIEBSWELLEN

Estremità d'albero uscita

Output shaft end

Ende der Abtriebswelle

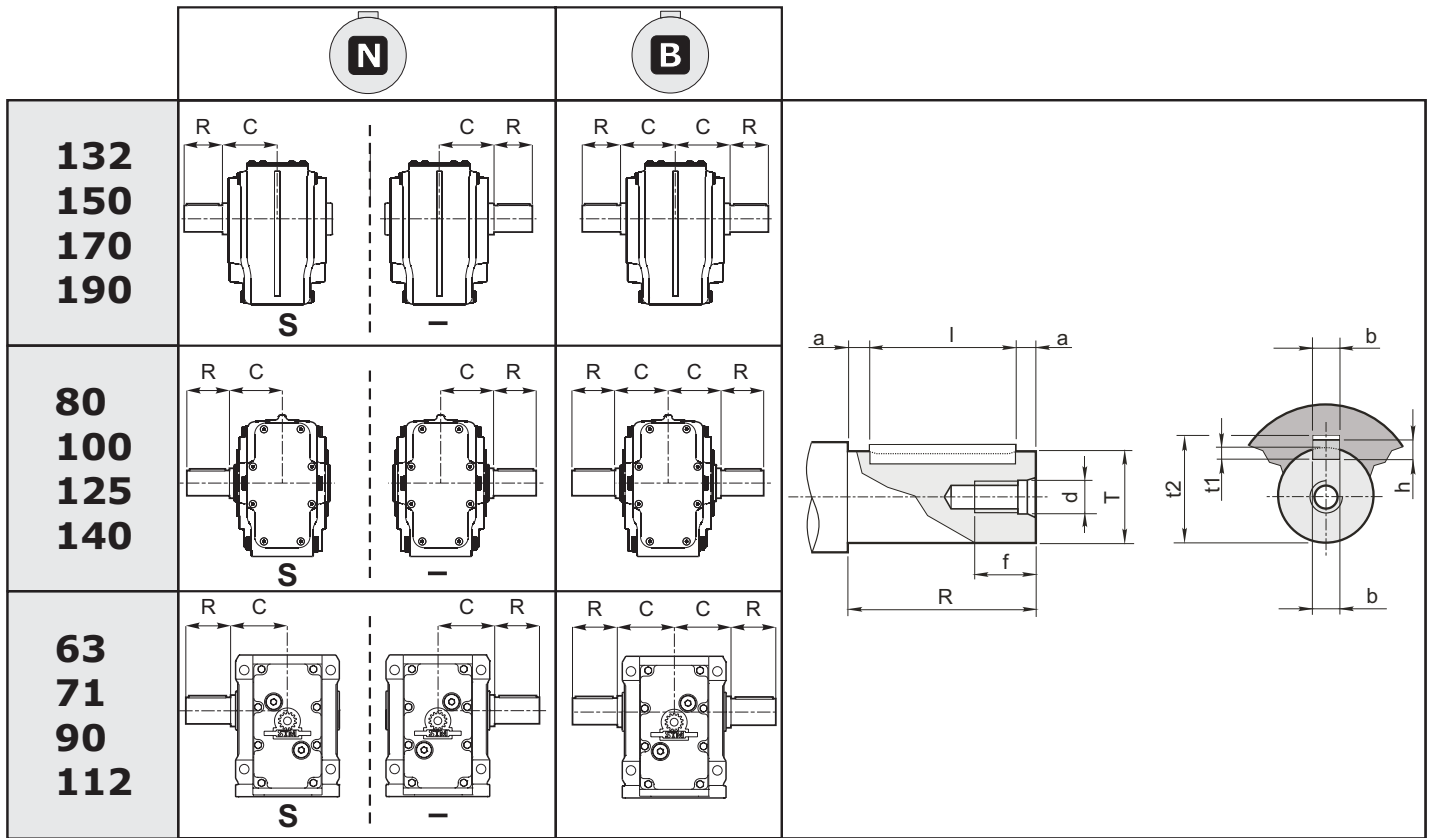

	Ø Albero Ø Shaft Ø Welle		Foro fil. testa Tapped hole Gewindebohrung Kopfi		Cava Keyway Nut			Estremità d'albero Shaft end Wellenende		Linguetta Key Federkeil
	T	C	d	f	b	t1	t2	R	a	bxhxl
63	30 g6	60	M 10	25	8	4	33.3	60	5	8X7X50
71	35 g6	75	M 10	25	10	5	38.3	70	5	10x8x60
80	32 k6	71	M8	22	10	5	35.3	60	5	10x8x50
90	40 g6	90	M 10	25	12	5	43.3	80	5	12x8x70
100	45 g6	77.5	M 10	25	14	5.5	48.8	90	5	14x9x80
112	50 g6	105	M 12	32	14	5.5	53.8	100	5	14x9x90
125	55 g6	90	M 12	32	16	6	59.3	110	5	16x10x100
132	60 m6	121	M 12	35	18	7	64.4	112	6	18x11x100
	70 m6		M 16	39	20	7.5	74.9	125	7.5	20x12x110
140	70 m6	122	M16	39	20	7.5	74.9	125	7.5	20x12x110
150	70 m6	137	M 16	39	20	7.5	74.9	125	7.5	20x12x110
	80 m6		M 16	39	22	9	85.4	140	7.5	22x14x125
170	90 m6	151	M 16	39	25	9	95.4	160	10	25x14x140
190	100 m6	170	M 20	46	28	10	106.4	180	10	28x16x160



ALBERI LENTI

Albero lento cavo

OUTPUT SHAFT

Output shaft with keyway

ABTRIEBSWELLEN

Abtriebswelle mit passfedernut

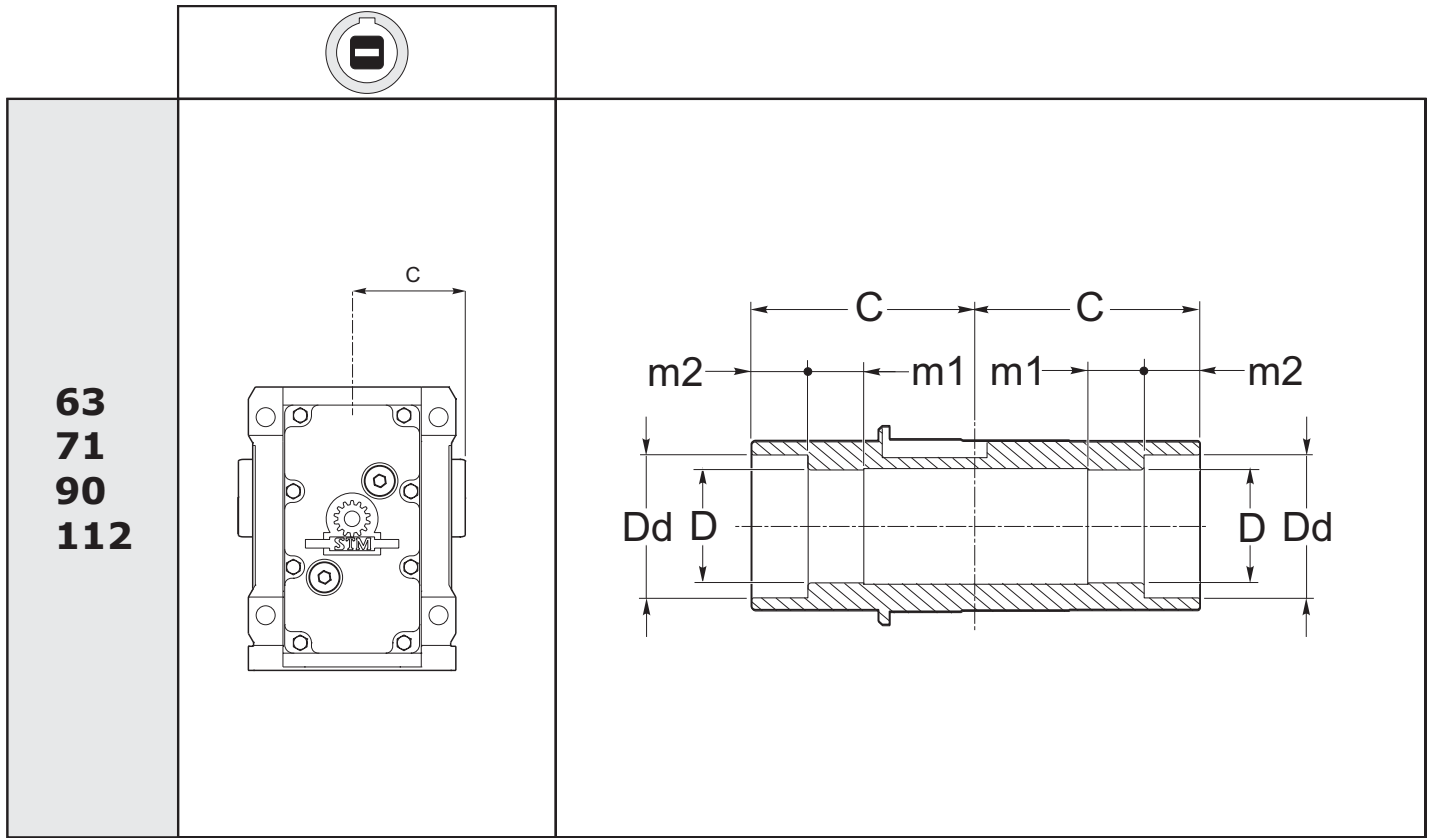

	63	71	90	112
C	60	75	90	105
D	30	35	40	50
H7	(25) (28)	(30) (32)	(42) (45) (48)	(55)
m1	15	30	35	35
m2	15	15	20	25
Dd	38	43	55	61

Perno macchina / Customer shaft / Maschinachse

	d1 h6	m3	Lm	m	H	L min	P	R	Ra	Rb
63	30 (25) (28)	20	25 (25) (25)	M 10 (M 8) (M 10)	88	50	29.8 (24.8) (27.8)	36		
71	35 (30) (32)	35	25	M 10	118	60	34.8 (29.8) (31.8)	42.5		
90	40 (42) (45) (48)	40	25	M 10	138	90	39.8 (41.8) (44.8) (47.8)	54.5		
112	50 (55)	35	32	M 12	158	110	49.8 (54.8)	60		

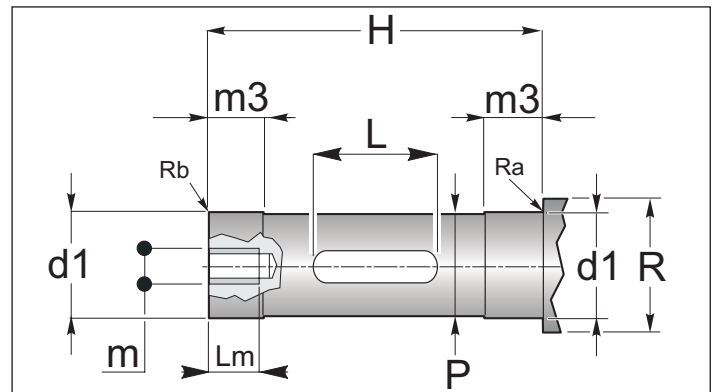



ALBERI LENTI

Albero lento cavo

OUTPUT SHAFT

Output shaft with keyway

ABTRIEBSWELLEN

Abtriebswelle mit passfedernut

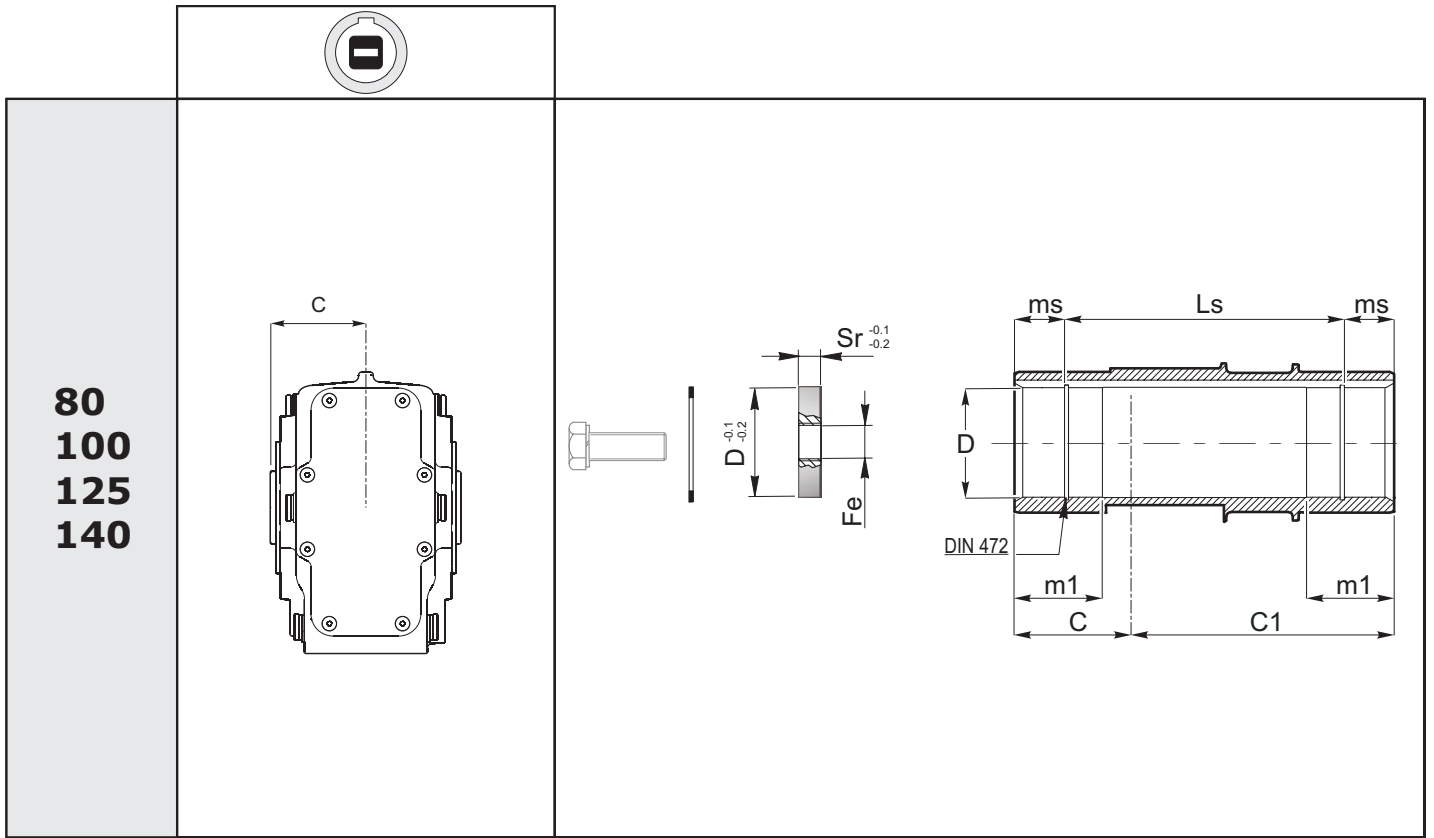

80
100
125
140

	80	100	125	140
C	65	77,5	90	110
D H7	32 (30) (35)	45 (40) (50)	55 (50) (60)	70 (60)
m1	35	42.5	55	60
ms	15	15	17.5	17.5
Ls	100	125	145	185

Perno macchina / Customer shaft / Maschinachse

	d1 h6	m3	m3s	Lm	m	H	L min	P	R	Ra	Rb	Sr	Fe
80	32 (30) (35)	30	30	25	M10	119	70	31.8 (29.8) (34.8)	42 (40) (45)			-	-
100	45 (50) (40)	45	15	25 (32) (25)	M 10 (M 12) (M 10)	125	80	44.8 (49.8) (39.8)	55 (60) (50)			10	M14
125	55 (60) (50)	60	20	32	M 12	142	110	54.8 (59.8) (49.8)	65 (70) (60)			15	M14
140	70 (60)	40	40	40 (35)	M20 (M12)	198	150	69.8 (59.8)	80 (70)			-	-

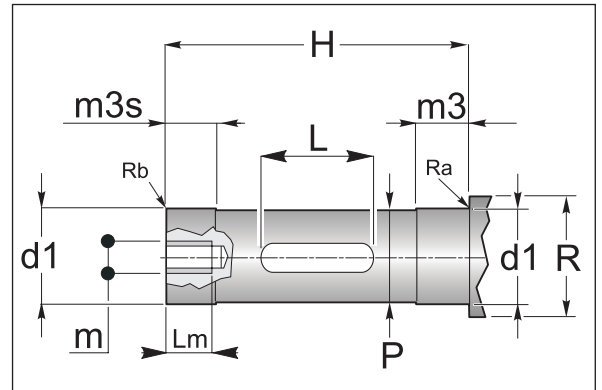



ALBERI LENTI

Albero lento cavo

OUTPUT SHAFT

Output shaft with keyway

ABTRIEBSWELLEN

Abtriebswelle mit passfedernut

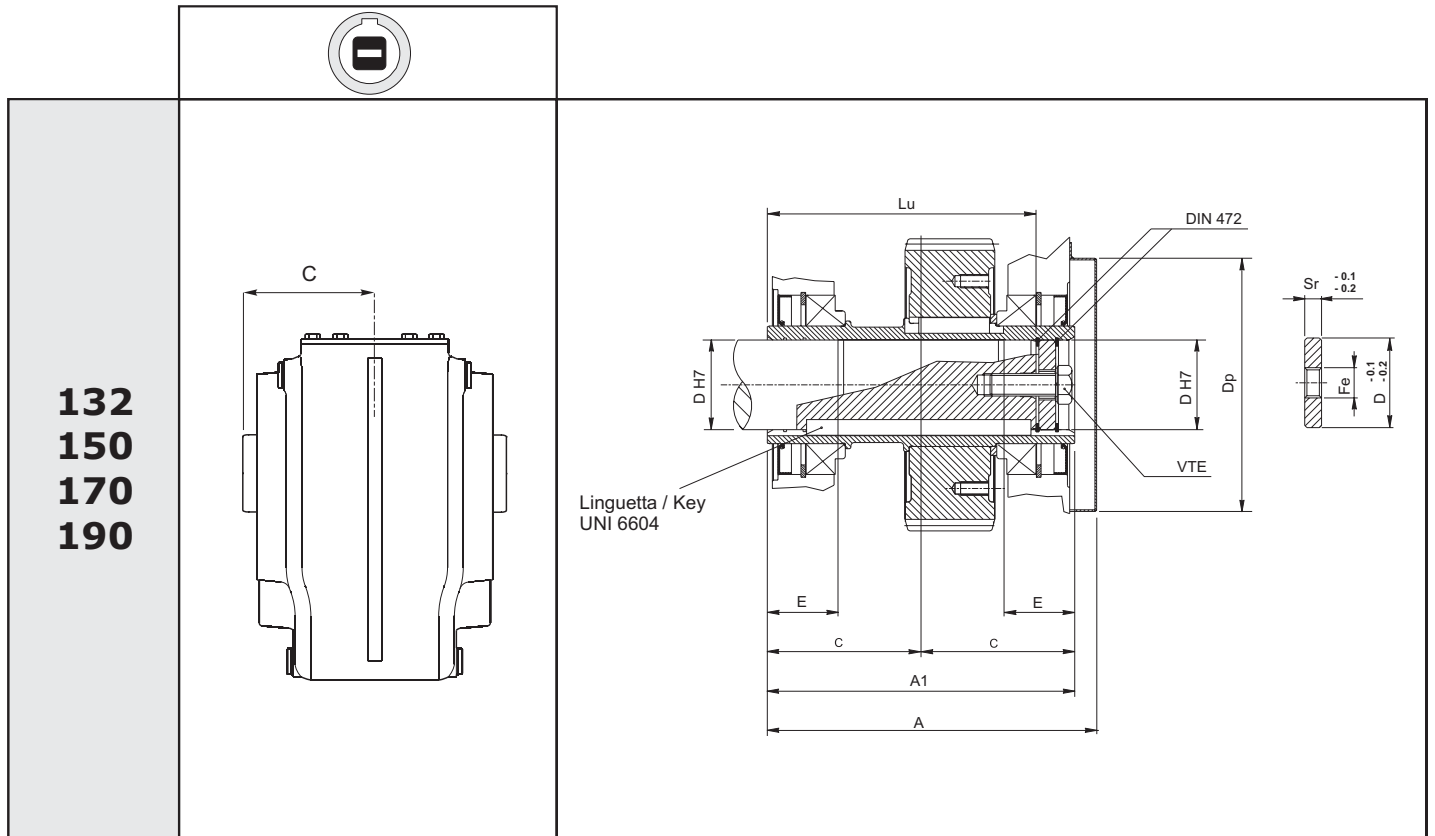

	132	150	170	190
A	269	302	332	379
A1	242	274	302	340
C	121	137	151	170
D	60 (70)	70 (80)	90	100
Dp	183	226	226	260
E	56	63	70	80
Lu	207.5	239.5	261	299
Sr	15	15	18	18
Fe	M27	M27	M30	M30
VTE	M20x60	M20x60	M24x75	M24x75

Albero Macchina / Machine shaft / Machine Shaft

	B	C	D	E	F	G	L	Lu	VTE
132	26.5	4	60 (70)	61	120	25	180	207.5	M20
150	33.5	4.5	70 (80)	68	138	36	200	239.5	M20
170	36	5	90	77	148	37	220	261	M24
190	44	5.5	100	85	170	43	250	299	M24

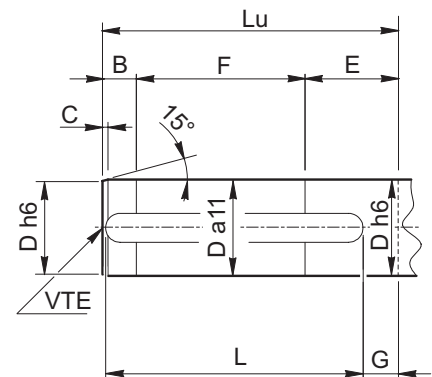



ALBERI LENTI

Albero lento "Quick Locking"

OUTPUT SHAFT

Output shaft "Quick Locking"

ABTRIEBSWELLEN

Abtriebswelle mit "Quick Locking"

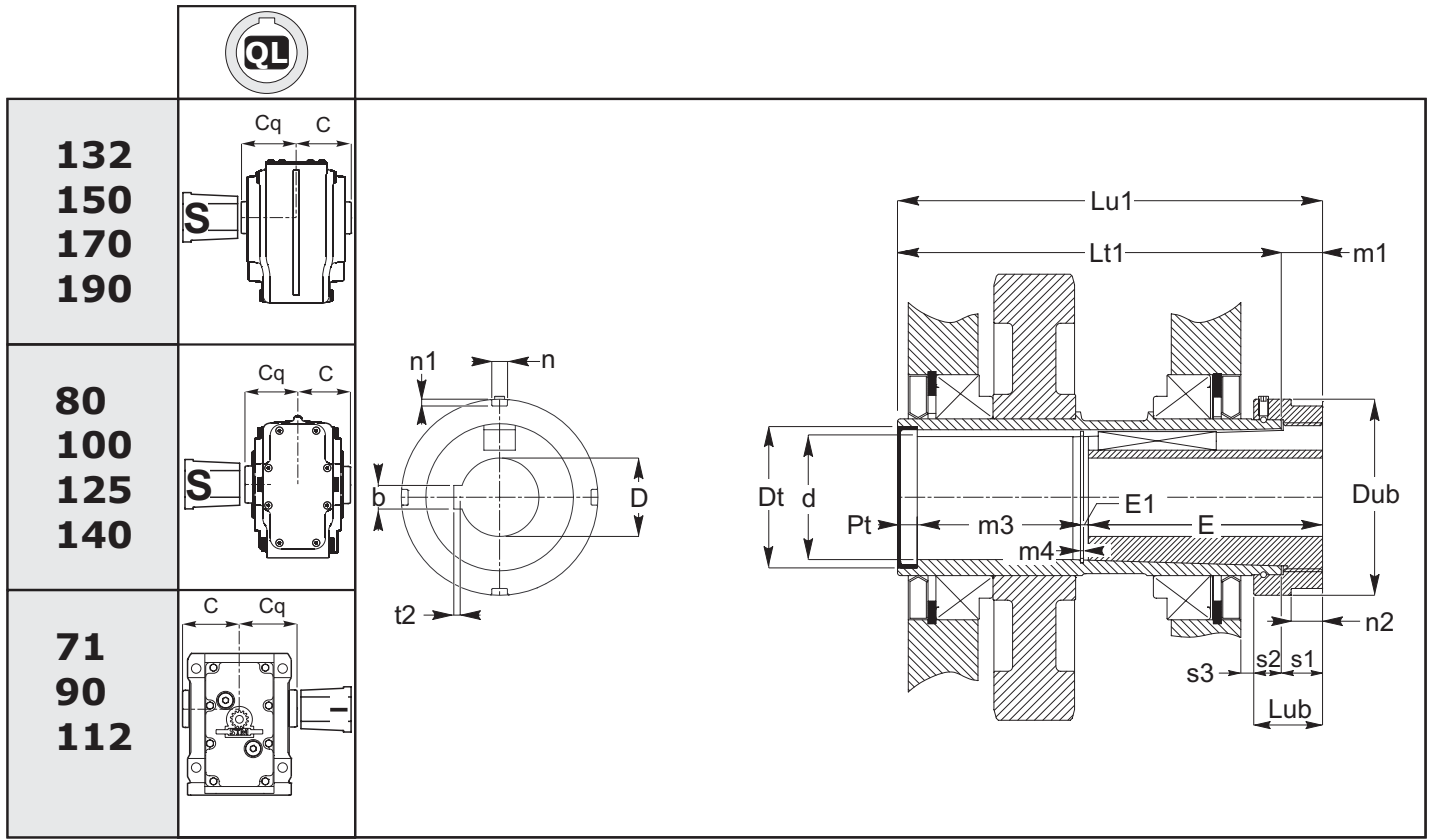

	71	80	90	100	112	125	132	140	150	170	190
C	75	65	90	77,5	105	90	121	110	137	151	170
Cq	111	101	126	113,5	141	126	157	146	173	187	206
d	35.2	35.2	49.2	49.2	54.2	60.2	70.2	69.2	80.2	90.2	100.2
dt	47	47	62	62	65	72	85	85	100	110	120
Dub	70	70	85	85	90	100	105	115	120	135	145
E	91	91	121	121	131	131	141	141	161	181	201
E1	3.5	3.5	3.5	3.5	3.5	3.5	4.2	4.2	4.2	4.2	5.2
Lt1	165	145	195	170	225	195	257	235	289	317	355
Lu1	186	166	216	191	246	216	278	256	310	338	376
Lub	35	35	35	35	35	35	35	35	35	35	35
m1	21	21	21	21	21	21	21	21	21	21	21
m3	84.5	64.5	83.5	58.5	101.5	71.5	120.8	98.8	132.8	140.8	157.8
m4	1.7	1.7	1.7	1.7	1.7	1.7	2.2	2.2	2.2	2.2	2.7
n2	15	15	15.5	15.5	15.5	16	16	16	17	17	17
s1	21	21	21	21	21	21	21	21	21	21	21
s2	14	14	14	14	14	14	14	14	14	14	14
s3	8	4.5	8	5	8.5	6.5	10	6	13	17	15
D	20	20	25	25	30	35	40	40	45	55	70
H7	25	25	30	30	35	40	45	45	50	60	75
	30	30	35	35	40	45	50	55	60	70	80
			38	38	45	50	55	60	65	75	85
			40	40	50	55	60	65	70	80	90
			45	45							
n	6	6	7	7	7	8	8	8	10	10	10
n1	2.5	2.5	3	3	3	3.5	3.5	3.5	4	4	4
b											
t2											

UNI 6604



ALBERI LENTI

Albero lento "Quick Locking"

OUTPUT SHAFT

Output shaft "Quick Locking"

ABTRIEBSWELLEN

Abtriebswelle mit "Quick Locking"

Perno macchina / Customer shaft / Maschinachse

	C	de h6	G	L	Lu	R	b1	t1
71	1	(20)	10	40	90	5		
		(25)		50				
		(30)		60				
80	1	(20)	10	40	90	5		
		(25)		50				
		(30)		60				
90	1.5	(25)	10	50	120	5		
		(30)		60				
		(35)		70				
		(38)		70				
		(40)		80				
100	1.5	(25)	10	50	120	5		
		(30)		60				
		(35)		70				
		(38)		70				
		(40)		80				
112	1.5	(30)	10	60	130	5		
		(35)		70				
		(40)		80				
		(45)		90				
		(50)		100				
125	1.5	(35)	10	70	130	5		
		(40)		80				
		(45)		90				
		(48)		90				
		(50)		100				
132	1.5	(40)	10	80	140	7.5		
		(45)		90				
		(50)		100				
		(55)		100				
		(60)		120				
140	1.5	(40)	10	80	140	7.5		
		(45)		90				
		(50)		100				
		(55)		100				
		(60)		120				
150	2	(45)	10	90	160	7.5		
		(50)		100				
		(55)		100				
		(60)		120				
		(65)		120				
170	2	(55)	10	100	180	7.5		
		(60)		120				
		(65)		120				
		(70)		120				
		(75)		150				
		(80)	5	150				

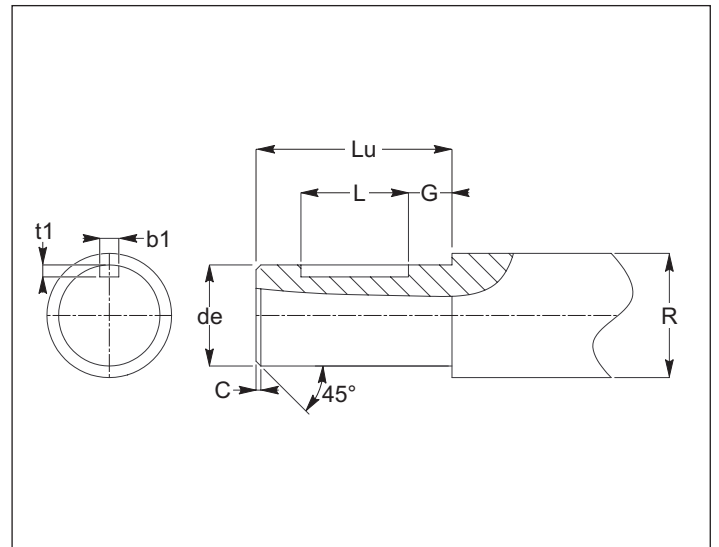
UNI
6604

ALBERI LENTI

OUTPUT SHAFT

ABTRIEBSWELLEN

Albero con calettatore

Output shaft with shrink disc

Abtriebswelle mit schrumpfscheibe

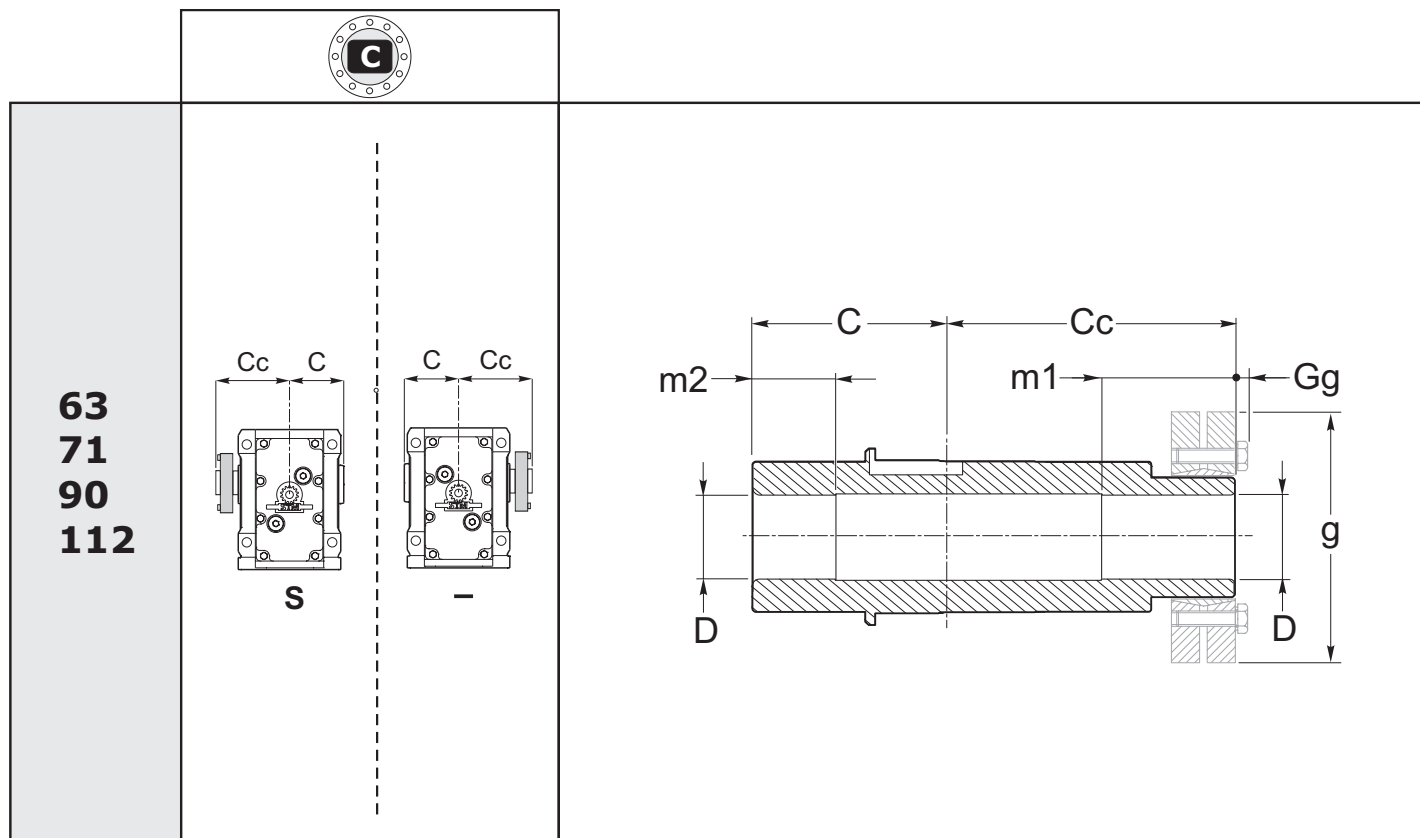

	63	71	90	112
C	60	75	90	105
Cc	85	100	120	140
D H7	30	35	40	50
m1	40	40	50	55
m2	25	25	30	40
g	72	80	90	110
Gg	4	4	6	1

Perno macchina / Customer shaft / Maschinachse

	d1 h6	H	m3	m4	P	R	Ra	Rb
63	30	145	45	30	29.8	36		
71	35	175	45	30	34.8	42.5		
90	40	210	55	35	39.8	54.5		
112	50	245	60	45	49.8	60		

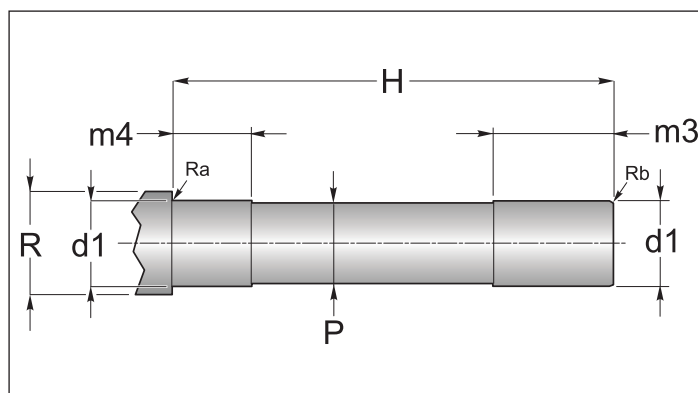



ALBERI LENTI

OUTPUT SHAFT

ABTRIEBSWELLEN

Albero con calettatore

Output shaft with shrink disc

Abtriebswelle mit schrumpfscheibe

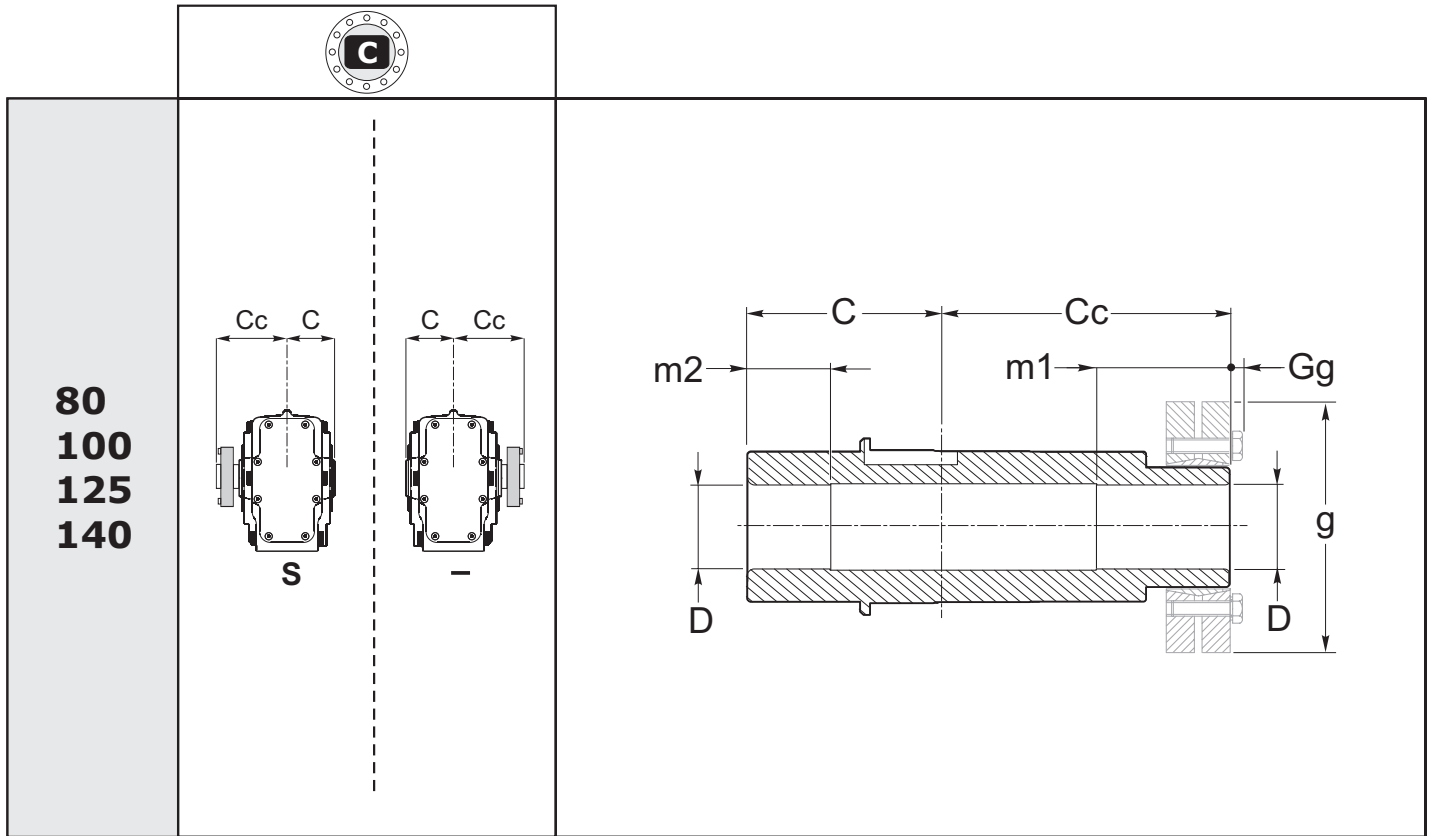

**80
100
125
140**

	80	100	125	140
C	65	77,5	90	110
Cc	95	107.5	125	154
D H7	35	45	55	70
m1	40	50	60	70
m2	30	30	50	60
g	80	100	115	155
Gg	-	4	4	-

Perno macchina / Customer shaft / Maschinachse

	d1 h6	H	m3	m4	P	R	Ra	Rb
80								
100	45	185	55	35	44.8	55		
125	55	215	65	55	54.8	65		
140								

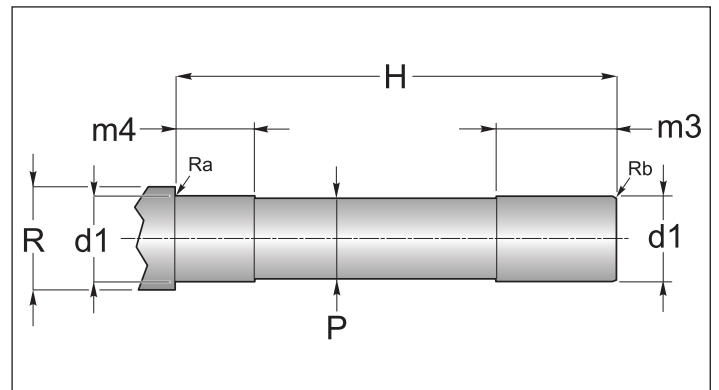

*Contattare il ns. servizio tecnico / Contact our technical dept / Wenden Sie sich an unseren technischen Service



ALBERI LENTI

OUTPUT SHAFT

ABTRIEBSWELLEN

Albero con calettatore

Output shaft with shrink disc

Abtriebswelle mit schrumpfscheibe

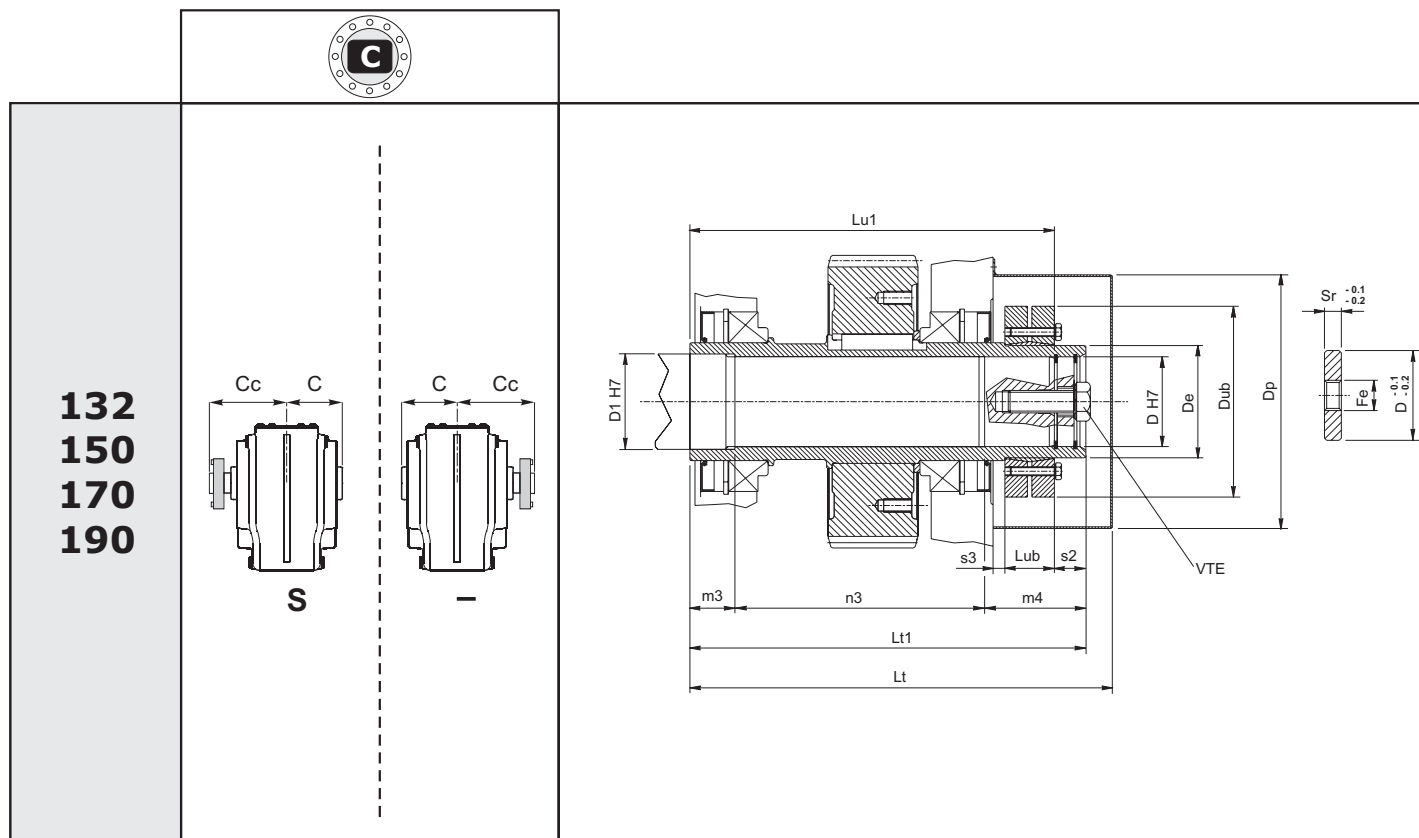

	132		150		170		190	
Lt	334.5		375.5		405.5		452.5	
Lt1	313		352		397		436	
m3	35		40		45		50	
n3	198		222		252		276	
m4	80		90		100		110	
Lu1	286		324		364		402	
Dp	183		226		226		260	
Dub	145	155	155	170	215	215	215	215
Lub	32.5	39	39	44	54	54	54	54
s2	30	27	30	28	33	33	34	34
C	121		137		151		170	
Cc	192		215		246		266	
D	60	70 (opz)	70	80 (opz)	90	90	100	100
D1	65	75	75	85	95	95	110	110
De	80	90	90	100	120	120	130	130
Sr	15		15		18		18	
Fe	M27		M27		M30		M30	
VTE	M20x60		M20x60		M24x75		M24x75	

Perno macchina / Customer shaft / Maschinachse

	132	150	170	190
B	58	67	72	81
C	4	4.5	5	5.5
D	60 (70)	70 (80)	90	100
D1	65 (75)	75 (85)	95	110
E	30	32	35	40
F	198	225	257	281
Lu1	286	324	364	402
M	M20	M20	M24	M24
R	2.2	2.5	2.5	3

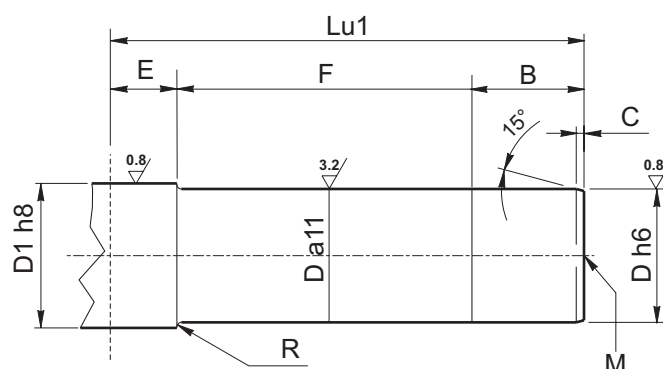



HIGH TECH

line

ALBERI LENTI

OUTPUT SHAFT

ABTRIEBSWELLEN

Estremità albero lento scanalato senza flangia brocciata

Splined output shaft without broached flange

Abtriebswelle mit Keilende ohne geräumtem Flansch

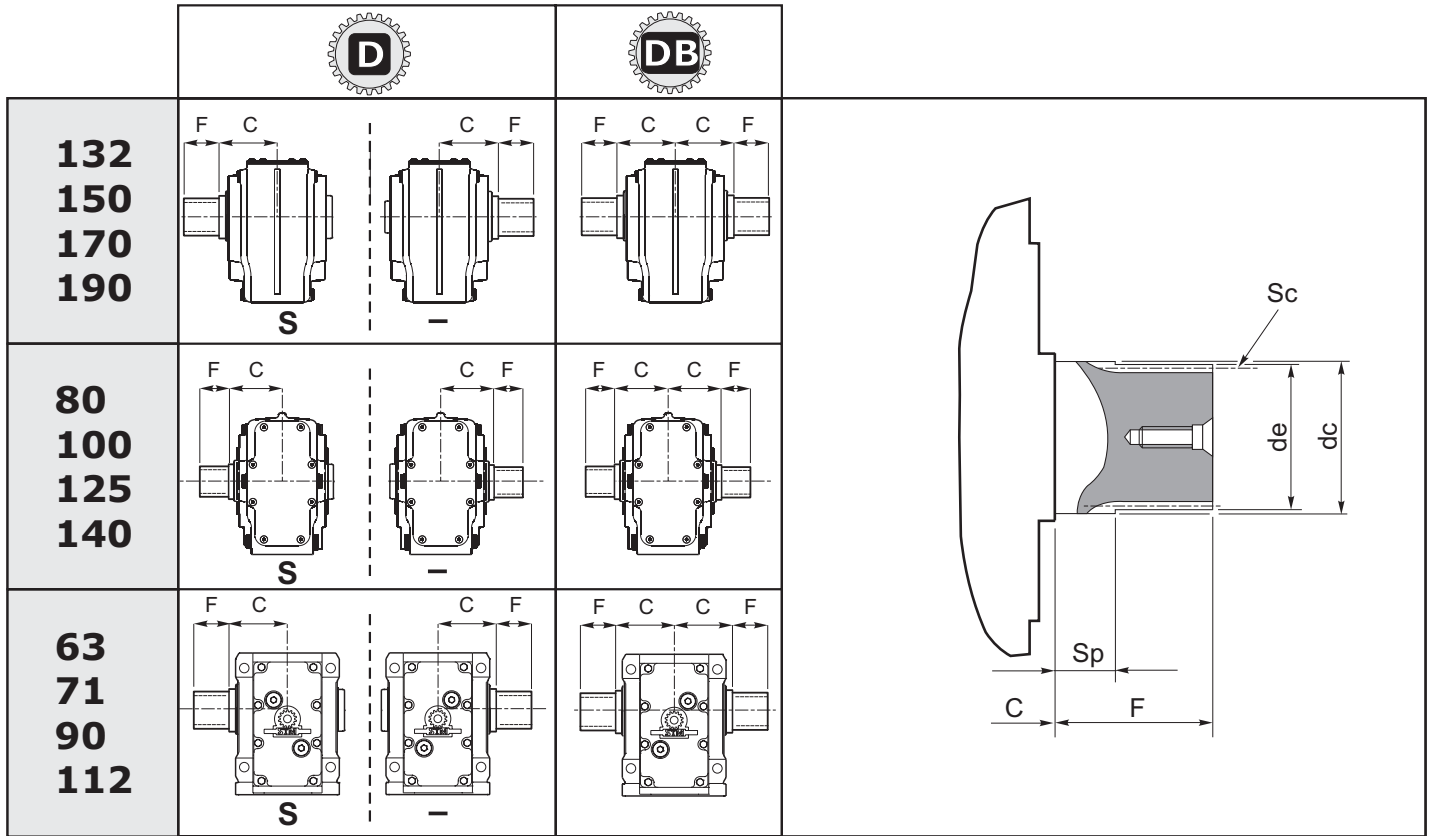

	C	de (h10)	F	Profilo scanalato / Splined profile / Keilprofil					
				Sc	Z	mn	α	dc (f7)	Sp
63	60	*		28 x 25 DIN 5482					
71	75			35 x 31 DIN 5482					
80	71			40 x 36 DIN 5482					
90	90			40 x 36 DIN 5482					
100	77.5			58 x 53 DIN 5482					
112	105			50 x 45 DIN 5482					
125	90			70 x 64 DIN 5482					
132	121	69.3	70	FIAT 70	26	2.58	30°	70	25
140	122	69.3	70	FIAT 70	26	2.58	30°	70	25
150	137	79.3	70	FIAT 80	27	2.82	30°	80	20
170	151	94.3	75	FIAT 95	31	2.97	30°	95	25
190	170	104.4	80	D. 105 DIN 5480	34	3	30°	106	25

*Contattare il ns. servizio tecnico / Contact our technical dept / Wenden Sie sich an unseren technischen Service

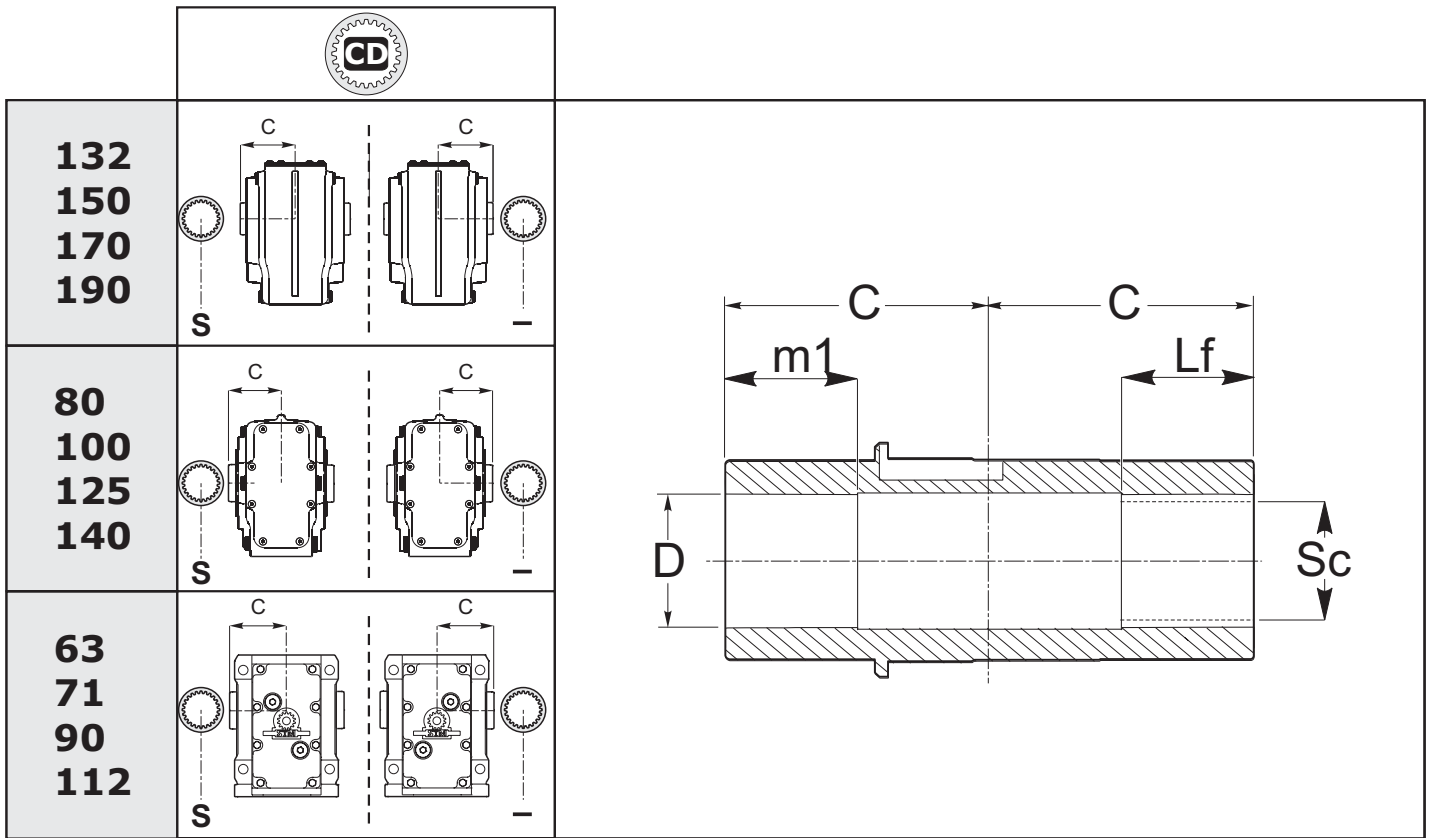

	63	71	80	90	100	112	125	132	140	150	170	190
C	60	75	65	90	77.5	105	90	121	110	137	151	170
D		37		45		55		72		82	92	102
H7	*		*		*		*		*			
m1		40		55		60		70		90	90	110
Lf		45		55		65		70		90	90	110
Sc	28 x 25 DIN 5482	35 x 31 DIN 5482	35 x 31 DIN 5482	40 x 36 DIN 5482	45 x 41 DIN 5482	50 x 45 DIN 5482	55 x 50 DIN 5482	70 x 64 DIN 5482	70 x 64 DIN 5482	80 x 74 DIN 5482	90 x 84 DIN 5482	100 x 94 DIN 5482

Perno macchina / Customer shaft / Maschinachse

	d1 h6	m3	H	P	R	Ra	Rb	Sc	F	Lf	L m	m
63												
71												
80												
90												
100												
112				*						*		
125												
132												
140												
150												
170												
190												

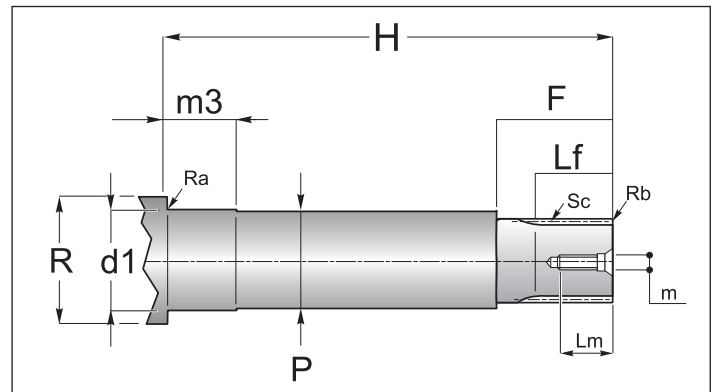

*Contattare il ns. servizio tecnico / Contact our technical dept / Wenden Sie sich an unseren technischen Service



ALBERI LENTI

OUTPUT SHAFT

ABTRIEBSWELLEN

Estremità scanalata albero lento flangia brocciata

Splined output shaft and broached flange

Abtriebswelle mit Keilende und geräumtem Flansch

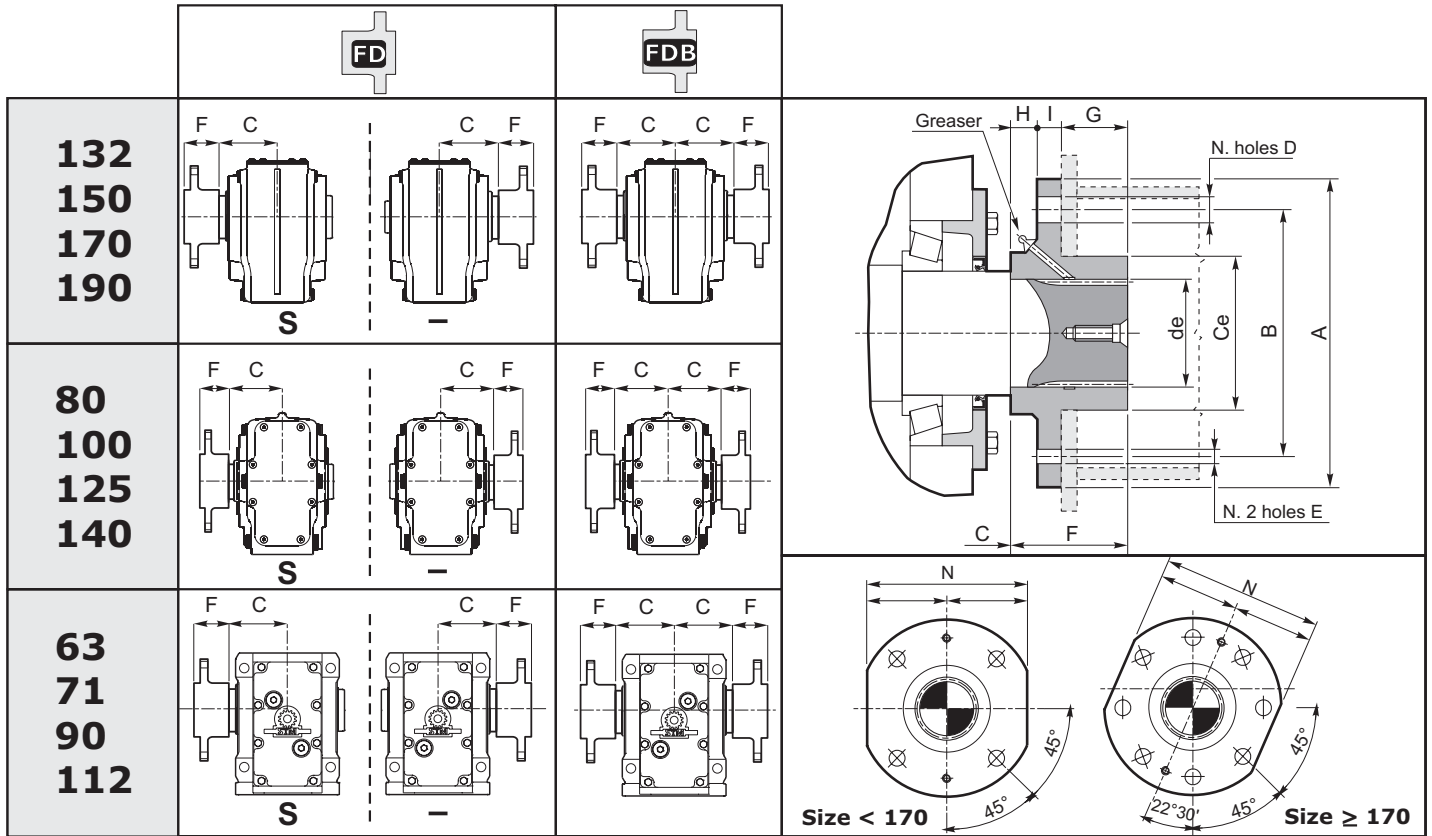

	Dimensioni generali / General dimensions / Allgemeine Abmessungen												
	de	∅ A	∅ B	C	∅ Ce f8	N° Fori holes Anzahl der Bohrungen	∅ D	E	F	G	H	I	N h9
63	*			60	100	4	17.5	M10	70	43	11	16	180
71				75									
80				71									
90				90									
100				77.5									
112				105									
125				90									
132	70	200	160	121	100	4	17.5	M10	70	43	11	16	180
140	70	200	160	122	100	4	17.5	M10	70	43	11	16	180
150	80	220	180	137	110	4	19.5	M10	70	40	12	18	200
170	95	240	190	151	130	8	19.5	M10	75	40	15	20	220
190	105	250	200	170	145	8	21.5	M12	80	40	20	20	230

*Contattare il ns. servizio tecnico / Contact our technical dept / Wenden Sie sich an unseren technischen Service



1.9 Accessori

BRACCIO DI REAZIONE [T]

Per il fissaggio del riduttore mediante tirante, viene fornito in allegato l'apposito braccio di reazione con boccola Vulkolan di cui è possibile il montaggio nelle due posizioni "A" o "B".

1.9 Accessories

TORQUE ARM [T]

If the gearbox shall be shaft mounted as an extra part there is also available a torque arm with Vulkolan bushing, position "A" or "B".

1.9 Zubehör

DREHMOMENTSTÜTZE [T]

Soll das Getriebe pendelnd gelagert werden, so ist als Zubehörteil auch eine Drehmomentstütze mit Vulkolan-Lagerbushse erhältlich, Montageposition "A" oder "B".

63 - 71 -90 -112

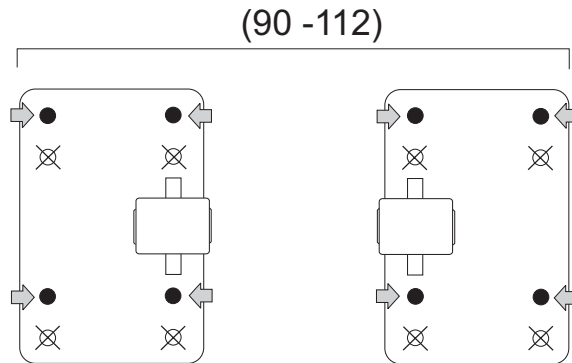
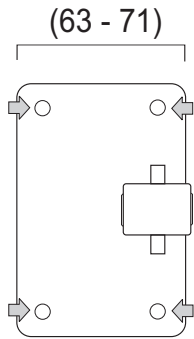

N.B.
Per il fissaggio del braccio di reazione al corpo fare riferimento C 38.

N.B.
To assembly torque arm look C 38

N.B.
Für die drehmomentstütze befestigen sehen sie zeichnung C 38.

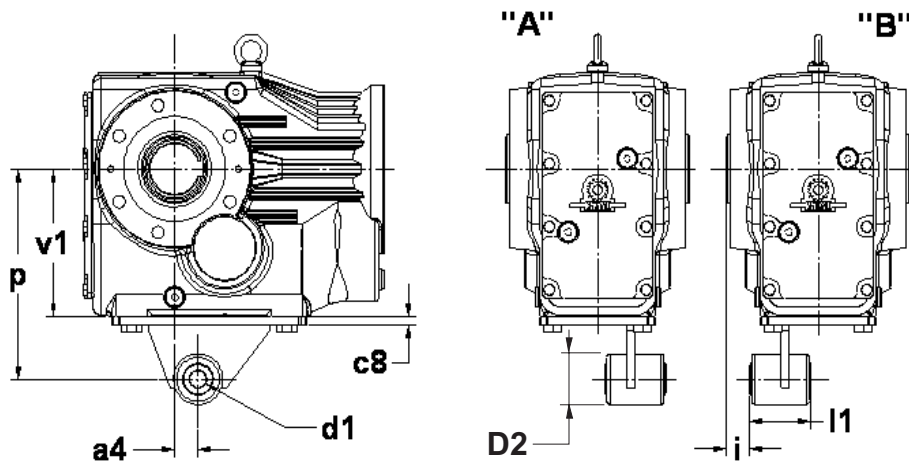

	a4	c8	D2	i	p	v1	d1	l1	viti
63	23.5	6	36	20	140	100	10 ± 0.1	34	N° 4TE M10x30 + N° 4 DADI
71	30	6	36	20	160	112	10 ± 0.1	34	N° 4TE M10x25
90	45	8	48	25	200	140	16 ± 0.1	56	N° 4TE M12x25
112	52.5	10	48	25	250	180	16 ± 0.1	56	N° 4TE M16x30



1.9 Accessori

1.9 Accessories

1.9 Zubehör

BRACCIO DI REAZIONE [T]

TORQUE ARM [T]

DREHMOMENTSTÜTZE [T]

80 - 100 - 125 - 140

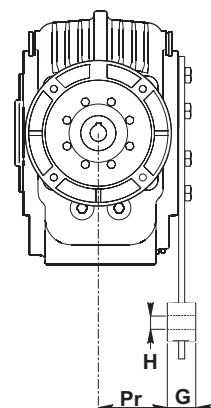
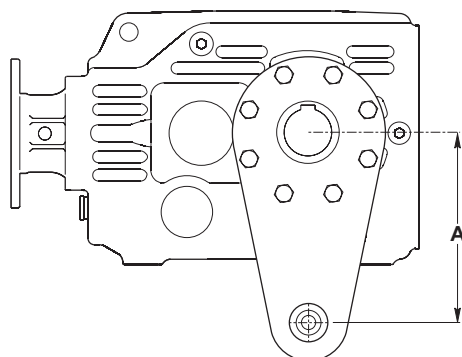

	BRACCIO DI REAZIONE [T] TORQUE ARM [T] DREHMOMENTSTÜTZE [T]			
	A	G	H	Pr
80	200	25	20	49
100	200	25	20	61
125	250	30	25	69
140	300	35	35	91

BRACCIO DI REAZIONE [T]

TORQUE ARM [T]

DREHMOMENTSTÜTZE [T]

132 - 150 - 170 - 190

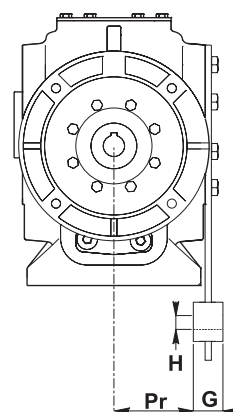
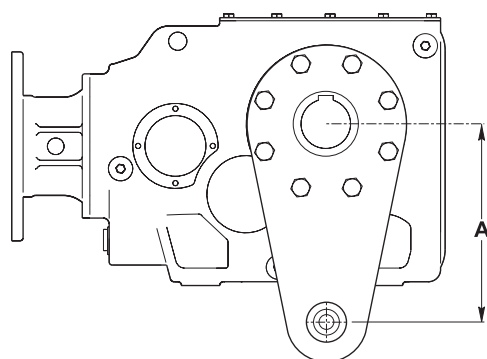

	BRACCIO DI REAZIONE [T] TORQUE ARM [T] DREHMOMENTSTÜTZE [T]			
	A	G	H	Pr
132	300	30	25	105
150	350	30	25	120.5
170	450	35	35	132.5
190	450	35	35	152.5



ALBERO LENTO SPORGENTE

Tutti i riduttori sono forniti con albero lento cavo. A richiesta, possono essere forniti kit di montaggio per alberi sporgenti comprensivi di linguette, rondelle e viti di fissaggio. Le dimensioni delle linguette sono conformi alle norme UNI 6604-69.

SINGLE OUTPUT SHAFTS

All gearboxes are supplied with hollow output shaft. On request there are available also assembly kits including output shafts, keys, washers and assembly screws. The dimensions of the keys are conform with UNI 6604-69.

EINSEITIGE ABTRIEBSWELLEN

Alle Getriebe werden mit Abtriebshohlwelle geliefert. Auf Anfrage sind auch Montagekits inklusive Abtriebswellen, Paßfedern, Unterlegscheiben und Montageschrauben erhältlich. Die Abmessungen der Paßfedern sind conform mit der UNI 6604-69.

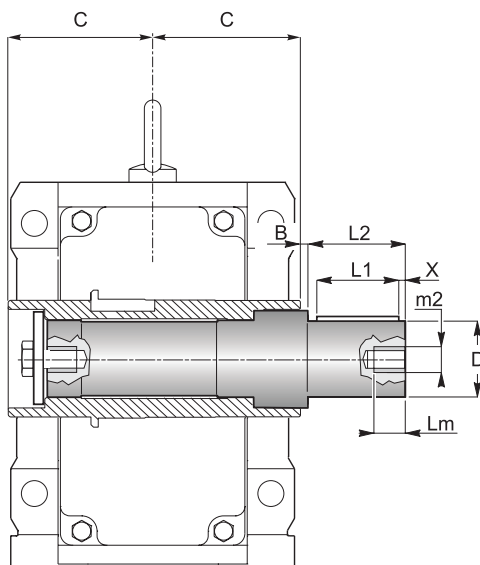

	B	C	D g6	m ₂	L ₁	L ₂	L _m	X
63*	1	60	30	M10	50	60	25	5
71*	1	75	35	M10	60	70	25	5
90*	1	90	40	M10	70	80	25	5
112*	1	105	50	M12	90	100	32	5

*** ATTENZIONE**

L'albero lento sporgente è fornito per essere installato sulla versione del riduttore con albero **CAVO** con diametro **STANDARD**.

***ATTENTION**

The output shaft is available only for standard hollow shaft diameter.

Achtung:

Die Einseitige Abtriebswelle wird fuer die Montage bei Getrieben mit Standart Hohlwelle geliefert.

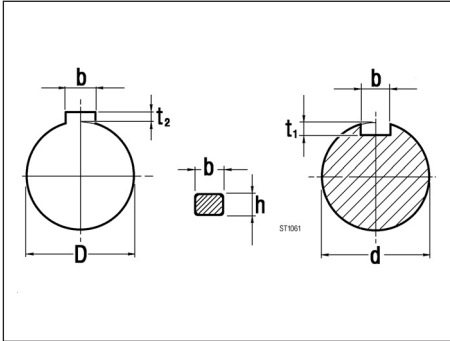

Albero entrata
Input shaft
Antriebswelle

Albero uscita
Output shaft
Abtriebswelle

Tab. 3.33

d	bxh	t1	
16	5x5	3	0/ +0.1
19	6x6	3.5	
24	8x7	4	0/ +0.2
28	8X7	4	
32	10X8	5	
35	10X8	5	
40	12X8	5	
50	14X9	5.5	

D	bxh	t2	
25	8x7	3.3	0/ +0.2
28	8x7	3.3	
30	8x7	3.3	
32	10x8	3.3	
35	10x8	3.3	
40	12x8	3.3	
42	12x8	3.3	
45	14x9	3.8	
48	14x9	3.8	
50	14x9	3.8	
55	16x10	4.3	
60	18X11	4.4	
70	20X12	4.9	
80	22X14	5.4	
90	25X14	5.4	
100	28X16	6.4	